



DE DANSKE STATSBANER

# DRIFTSMATERIEL II

GODSVOGNE m. m.

2det Distrikt  
Trafiktjenesten

1—IV



DANSKE STATSBANER

---

Fortegnelse

over

# Driftsmateriellet

2. Godsvogne, specialvogne og private vogne m.m.

April 1938

København, januar 1964

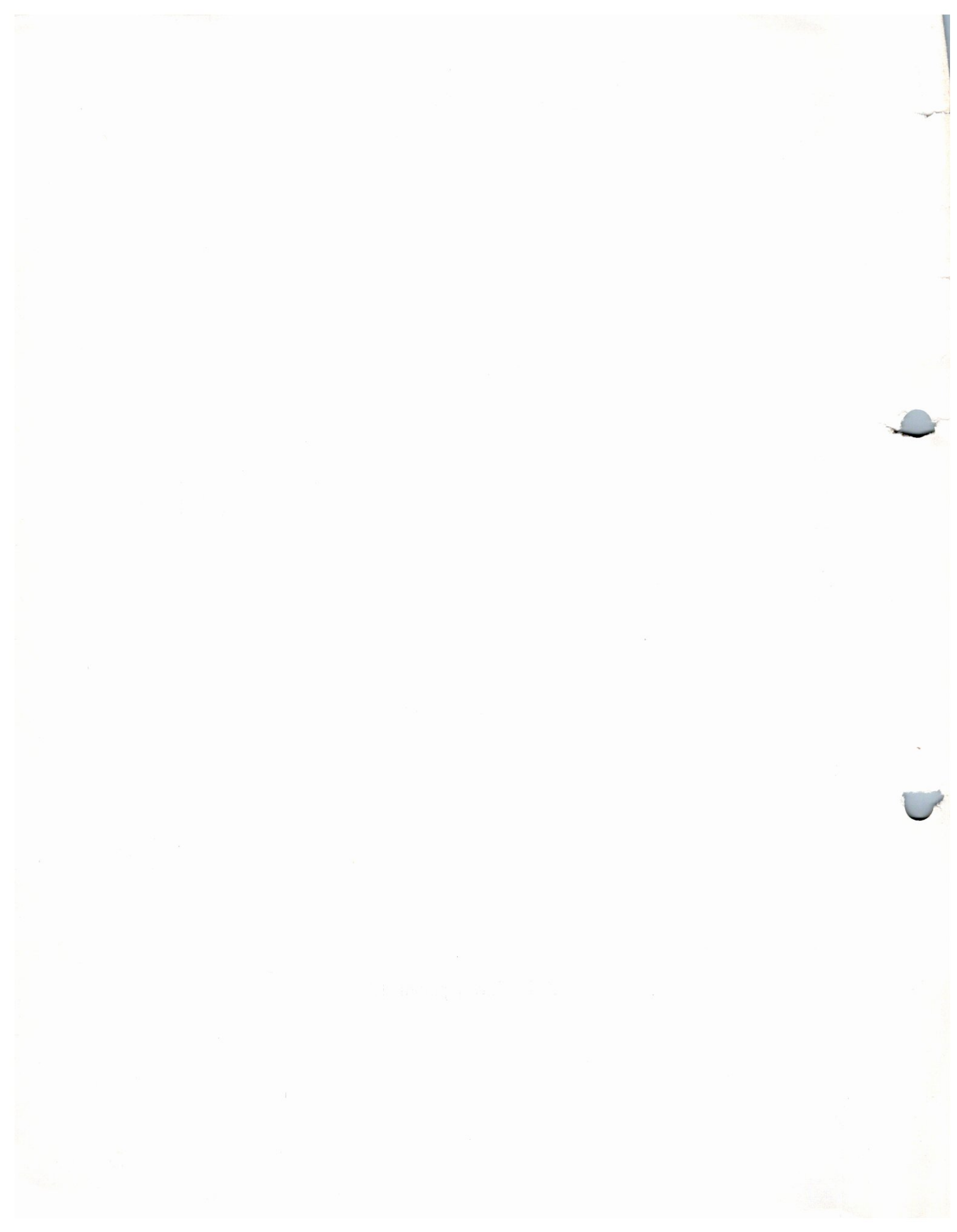

## Indholdsfortegnelse

<b>Lukkede vogne</b>		side
Litra •G	Brunmalede vogne .....	2
» •H	Hvidmalede » .....	19
» •I	Isolerede » .....	25
» •T	Specielle » .....	36
» •U	Beholder » .....	40
Tjenestegodsvogne .....		43
<b>Åbne vogne</b>		
Litra •E	Højsidede vogne .....	45
» •F	» » .....	47
» •K	Lavsidede » .....	52
» •R	» » .....	
» •S	» » .....	75
» •U	Forsænket vognbund .....	76-c
Tjenestegodsvogne .....		76-j
<b>Transportbeholdere</b>		
Kølebokse .....		76-o
Køletransportbeholdere .....		76-r
Transportbeholdere .....		78-c
<b>Specialvogne</b>		
Sneplove .....		87
Hjælpevogne .....		93
Kraner, løbevogne m. v. ....		98
Oversigt .....		181
<b>Private vogne</b>		
Nummerering .....		203
Oversigt .....		205

# MEMORANDUM

TO : SAC, [illegible]

FROM : [illegible]

SUBJECT: [illegible]

[illegible text]

[illegible text]

[illegible text]

[illegible text]

## • Gklm 111 7 000-111 7 516

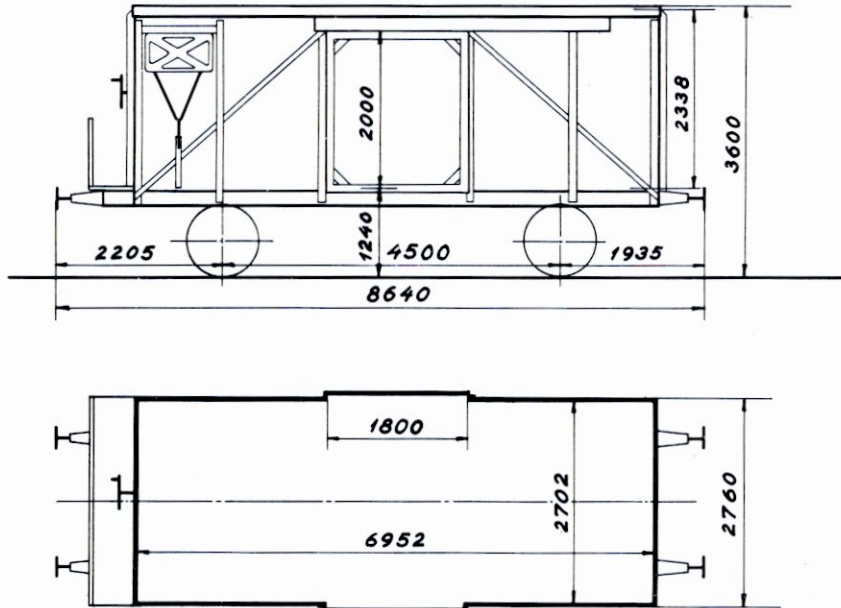

1918/27 Scandia  
Omb. 1959/63 Ar

Bundflade 18,8 m<sup>2</sup>

A	B	C
15,5 t		

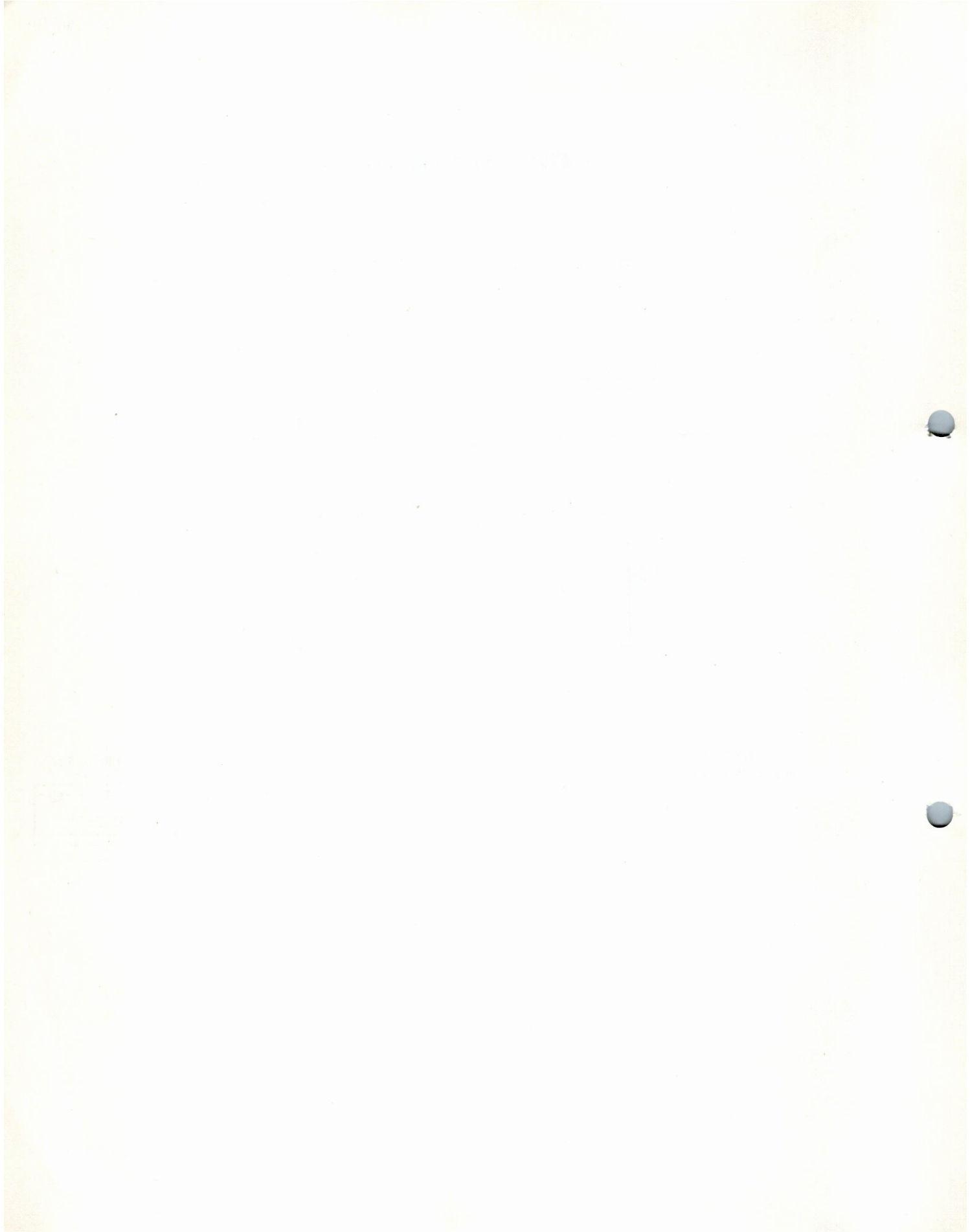



## . Gklm 111 8 000 - 111 8 783

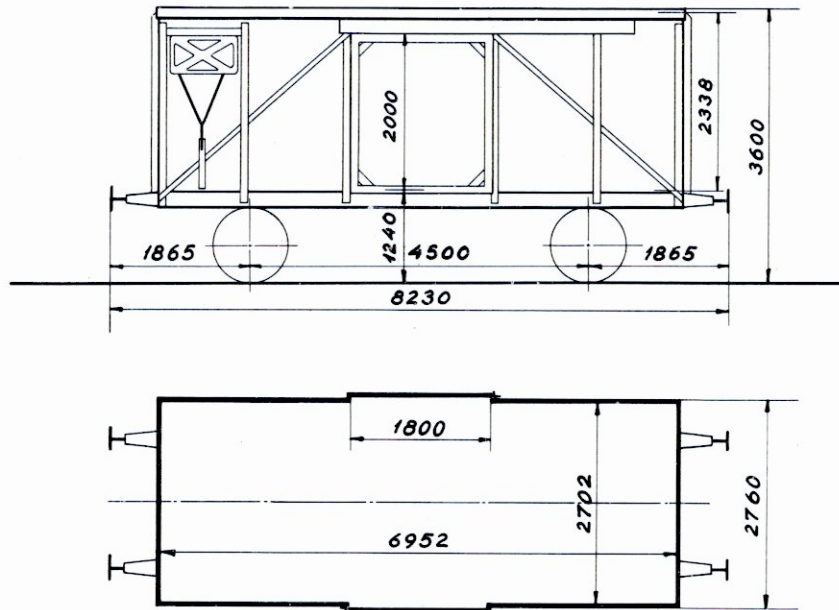

1917/24 Scandia  
Omb. 1959/63 Ar

Bundflade 18,8 m<sup>2</sup>

A	B	C
15,5 t		



- Gklm 111 6 100-111 6 128
- Gklm 111 6 200-111 6 239

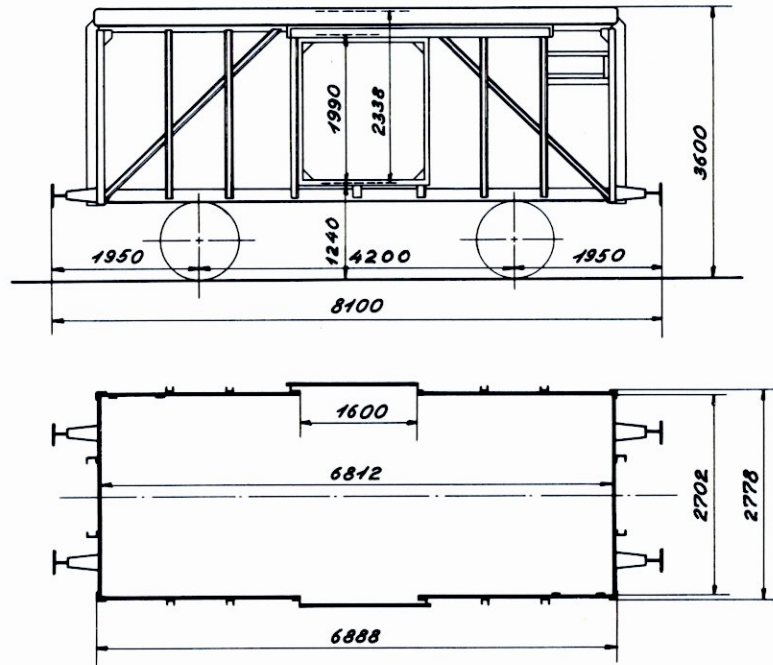

1920/24 Scandia  
Omb. 1956/57 Ar-Kh

Bundflade 18,4 m<sup>2</sup>

A	B	C
15,5 t		

1914

1914



## . Gklm 111 6 000-111 6 030

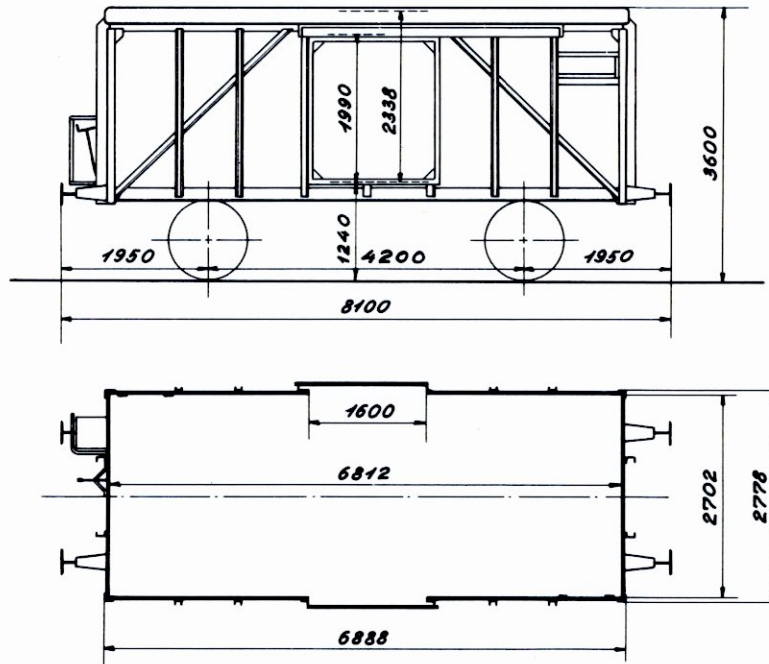

1920/24 Scania  
Omb. 1956/57 Ar

Bundflade 18,4 m<sup>2</sup>

A	B	C
15,5 t		

1000  
1000  
1000

1000  
1000

• Gklms 138 8 000-138 8 804

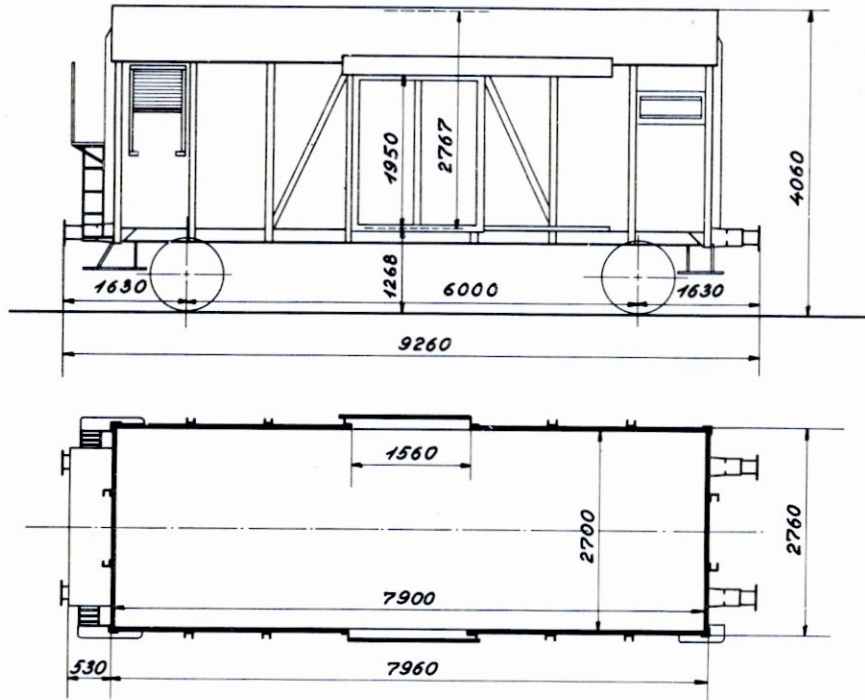

1942/50 Scandia

Bundflade 21,3 m<sup>2</sup>

	A	B	C
		17,5 t	
S		17,5 t	

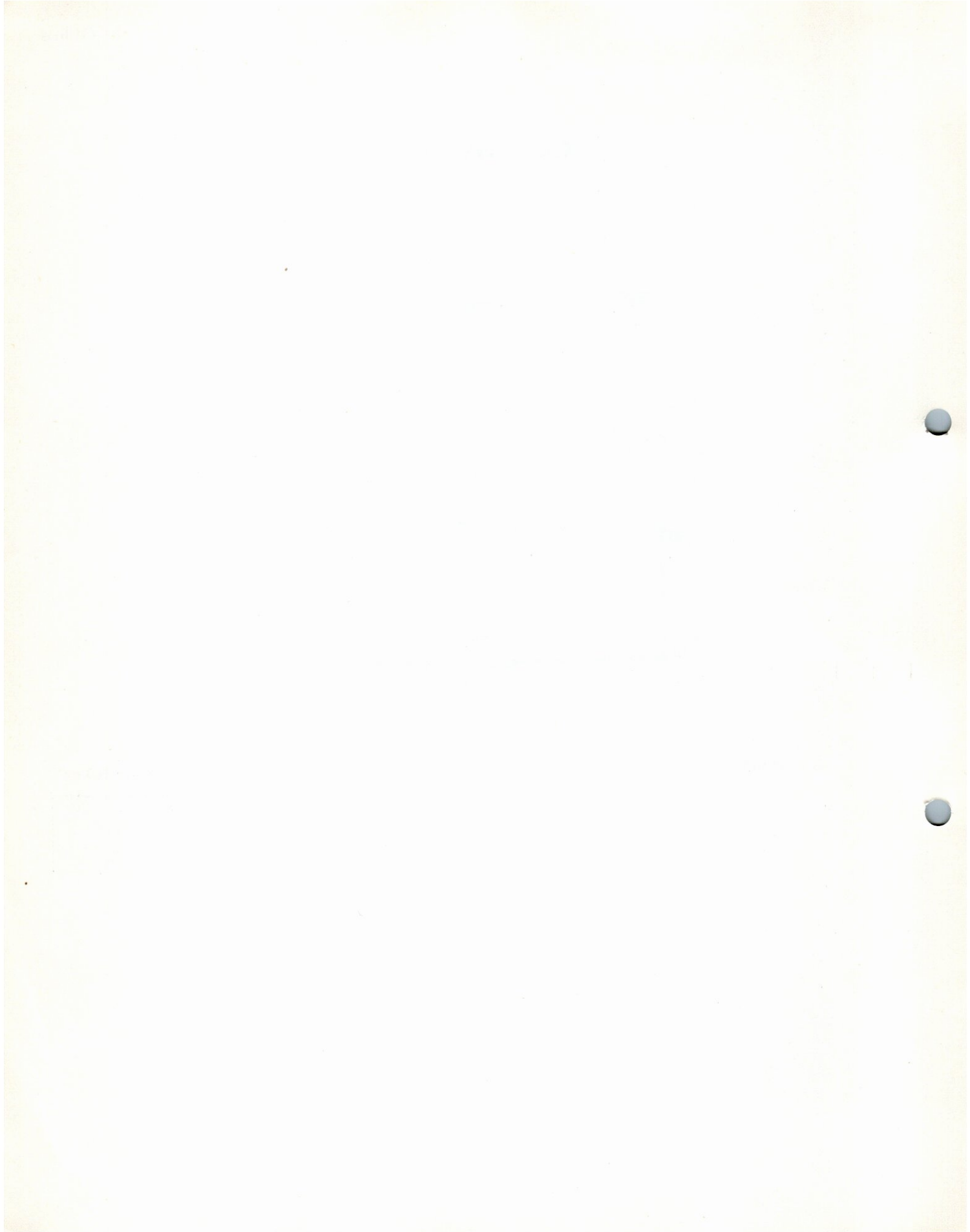



• Gkm 115 2 000-115 2 129

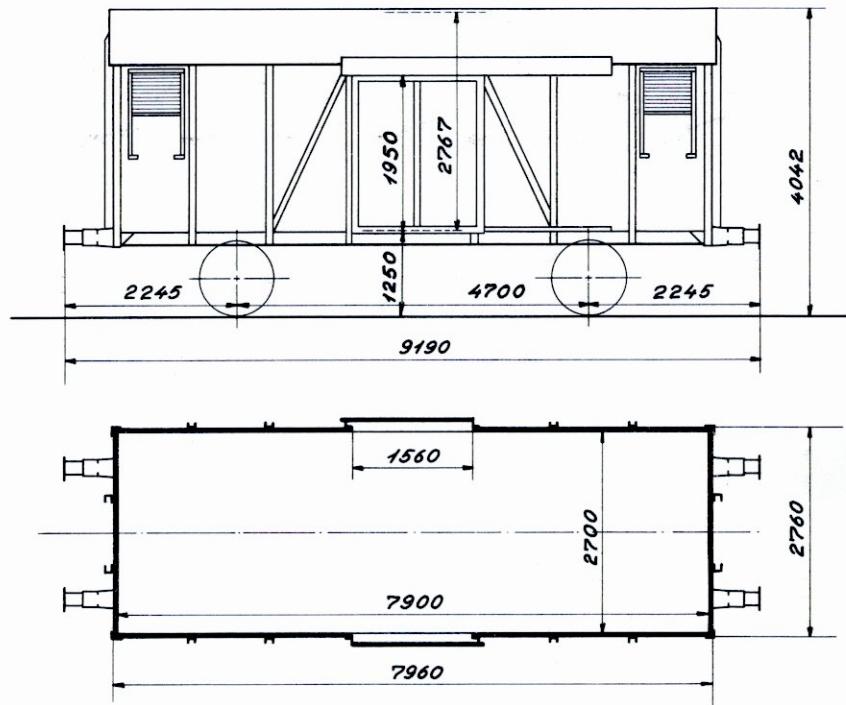

1931 Scania

Bundflade 21,3 m<sup>2</sup>

A	B	C
17,5 t		

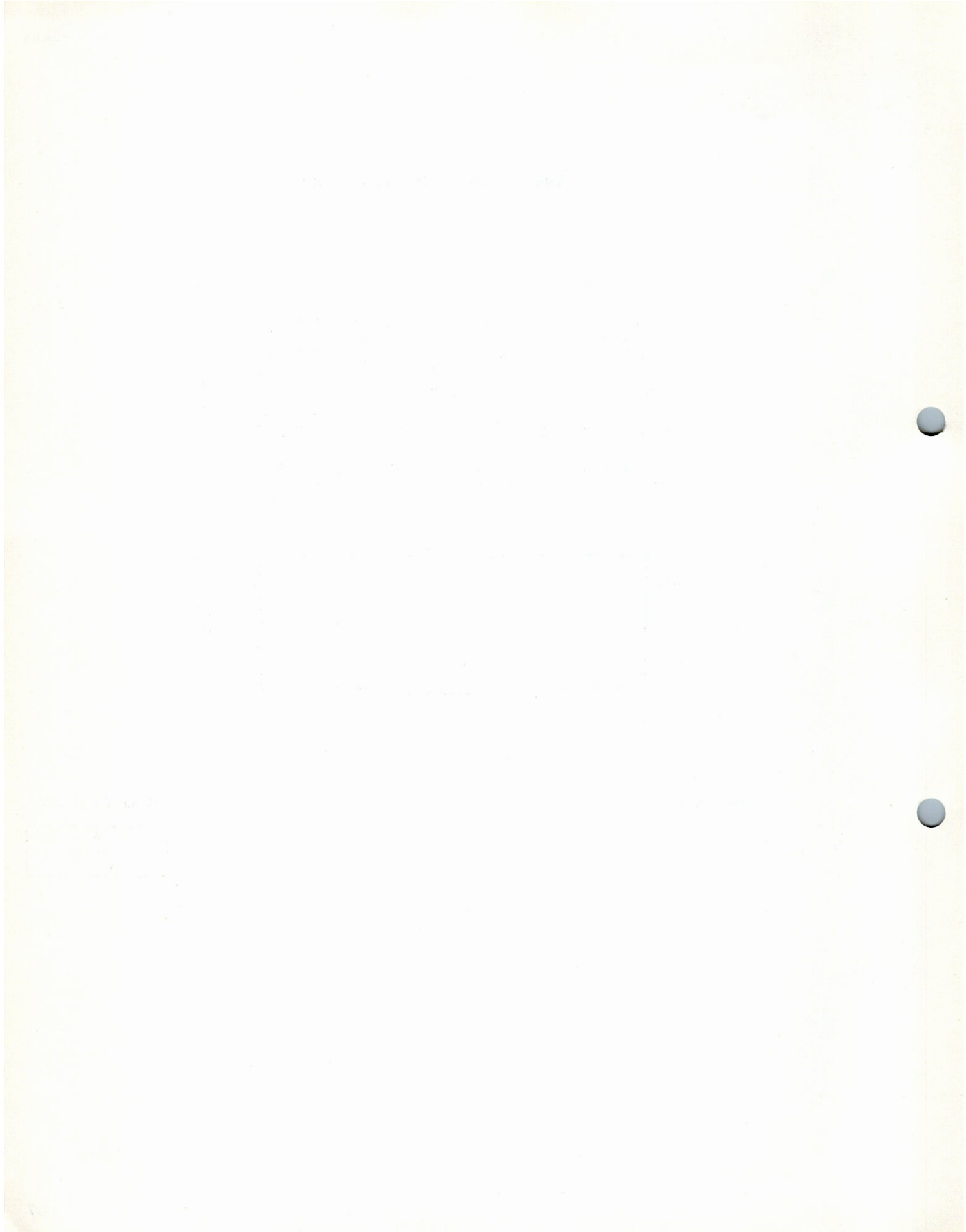

• Gkms 139 9 100-139 9 249

• Gkms 139 9 850-139 9 899

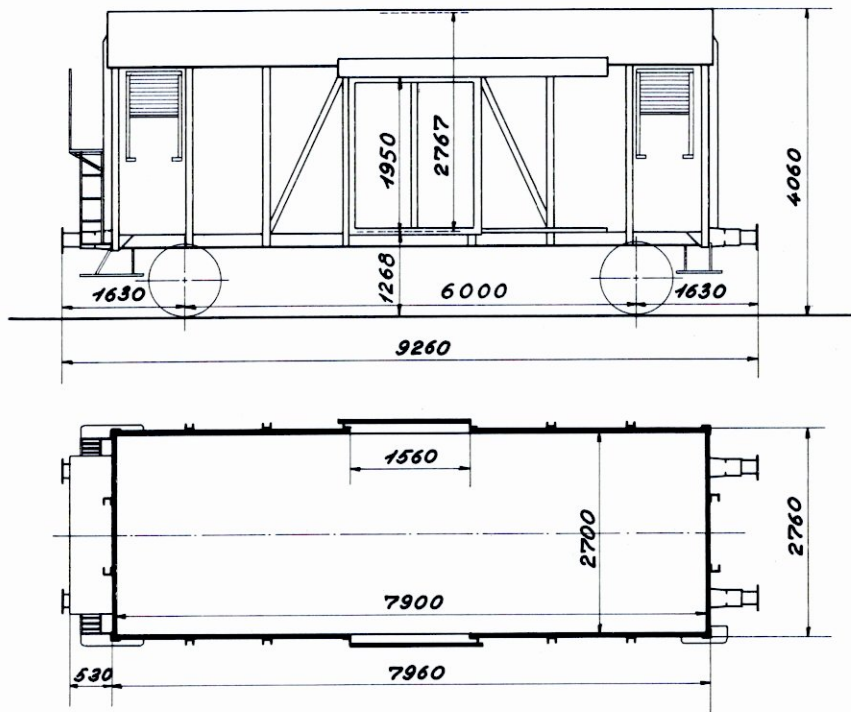

1944/48 Scania  
1947 »

Bundflade 21,3 m<sup>2</sup>

	A	B	C
		17,5 t	
S		17,5 t	

10/1/73



• Gkms 139 9 300 - 139 9 499

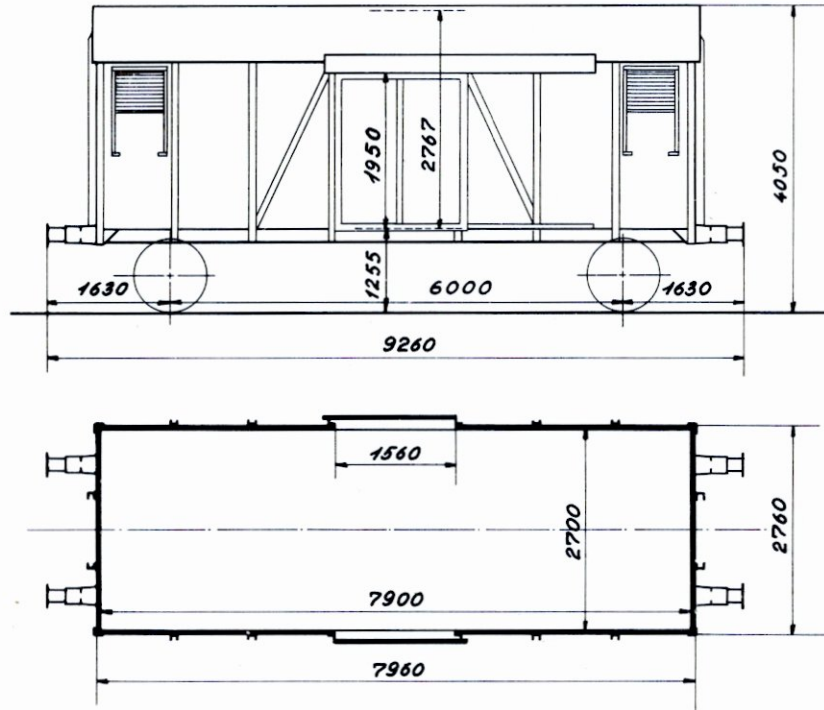

1940/41 Scania

Bundflade 21,3 m<sup>2</sup>

	A	B	C
		17,5 t	
S		17,5 t	



## Litra Gs

RIV

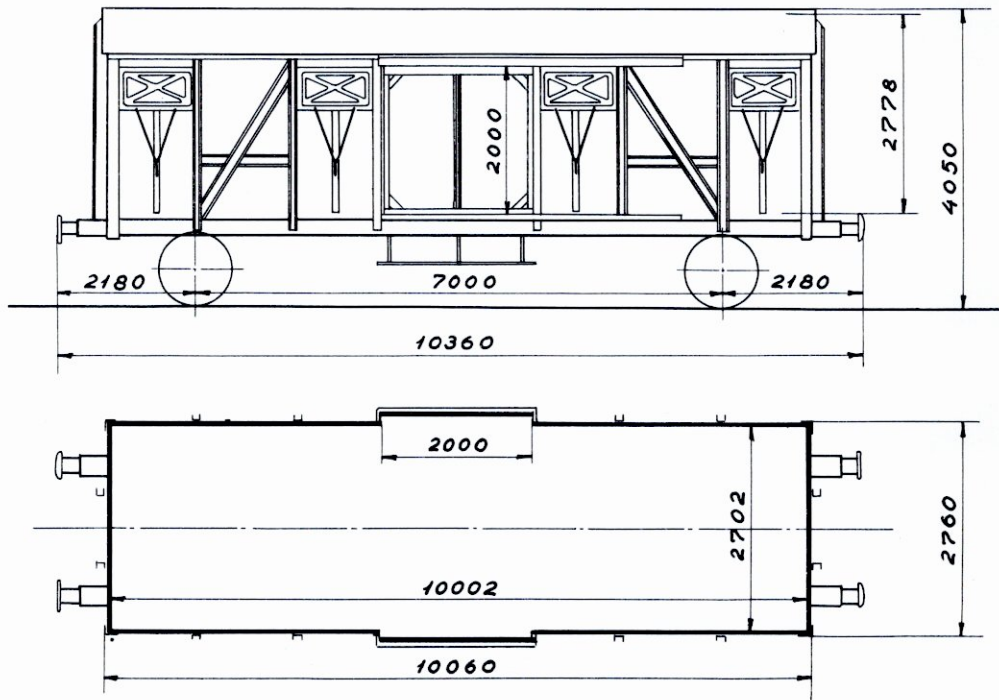
Bundflade 27,0 m<sup>2</sup>

	A	B	C
	19,0 t	21,0 t	
S	19,0 t	20,0 t	





• Gs-t 120 0 000-120 0 017

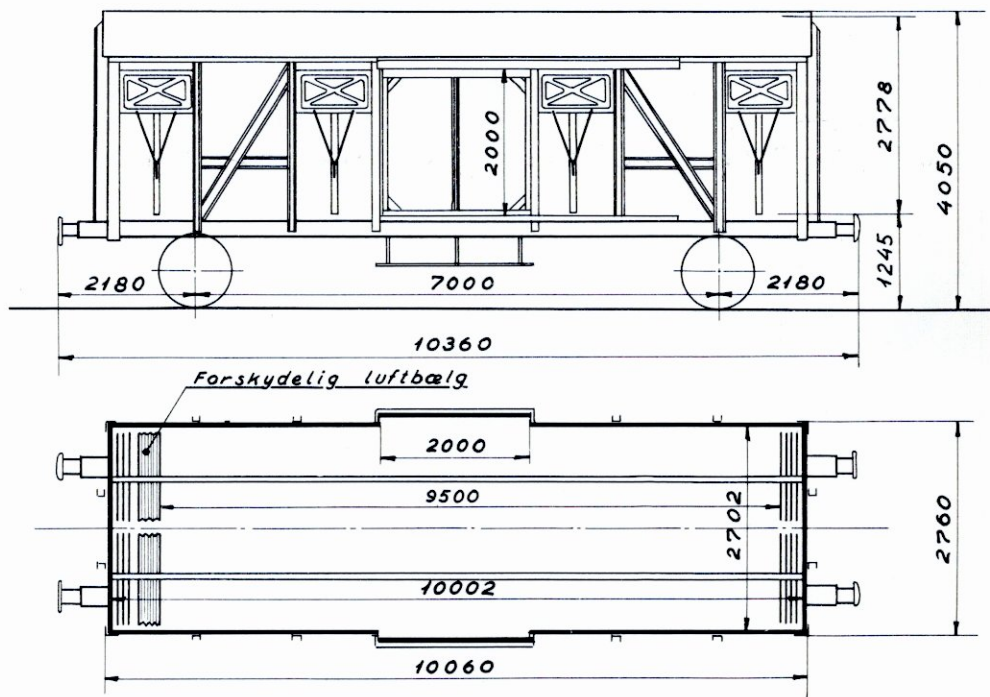

1941 Scandia  
Omb. 1964 Ar

Bundflade 25,7 m<sup>2</sup>

	A	B	C
	18,0 t	20,0 t	
S	18,0 t	19,0 t	



## • Gs-t 120 0 000-120 0 017

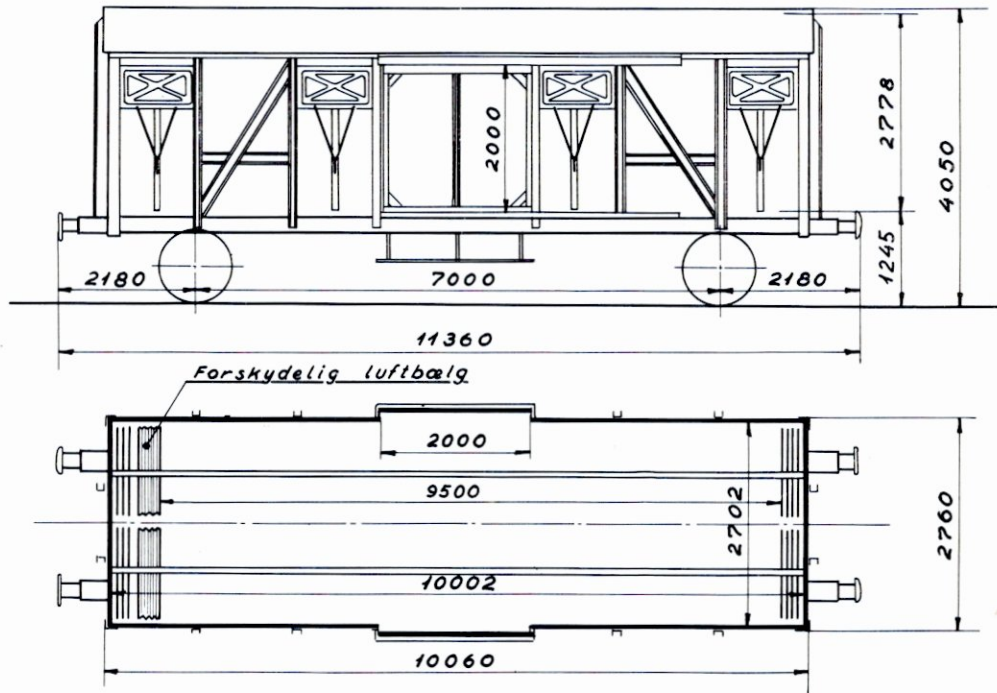

1941 Scandia  
Omb. 1964 Ar

Bundflade 25,7 m<sup>2</sup>

	A	B	C
	18,0 t	20,0 t	
S	18,0 t	19,0 t	



500 litra **G** nr. 40001—40500

RIV

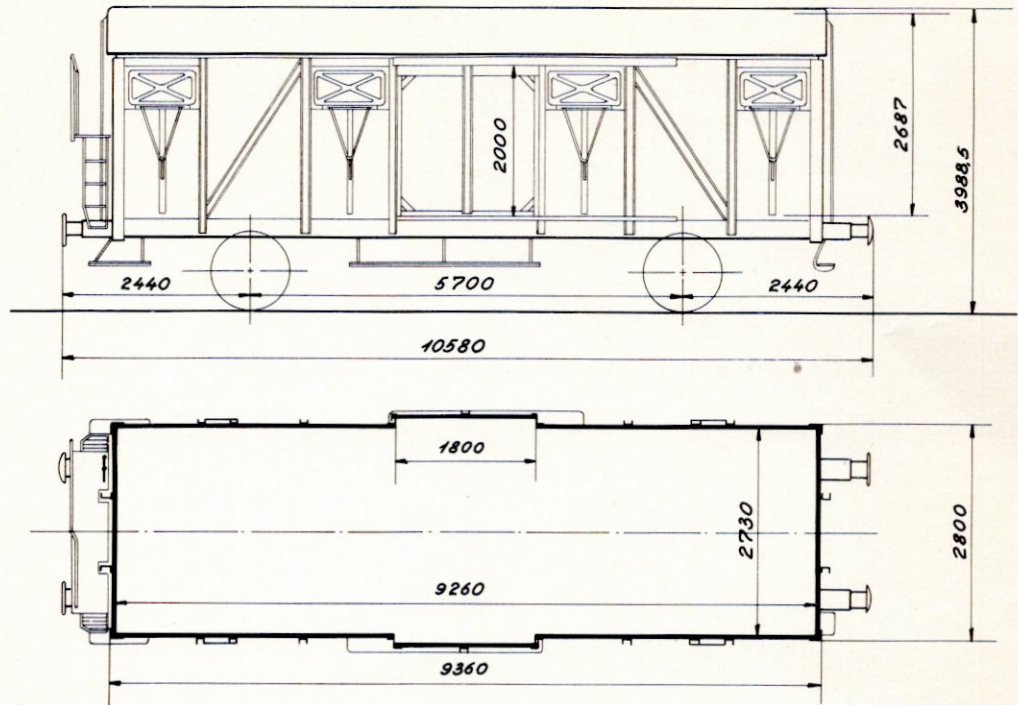

40001—40400. 1954—1955 Scandia  
 40401—40500. 1956 „

S — mærket  
 EUROP-mærket

Last 20000 kg  
 Bundflade 25,2 m<sup>2</sup>  
 Tara ca. 12200 kg  
 Trykluftbremse (G-P)  
 Rangnerskruebremse

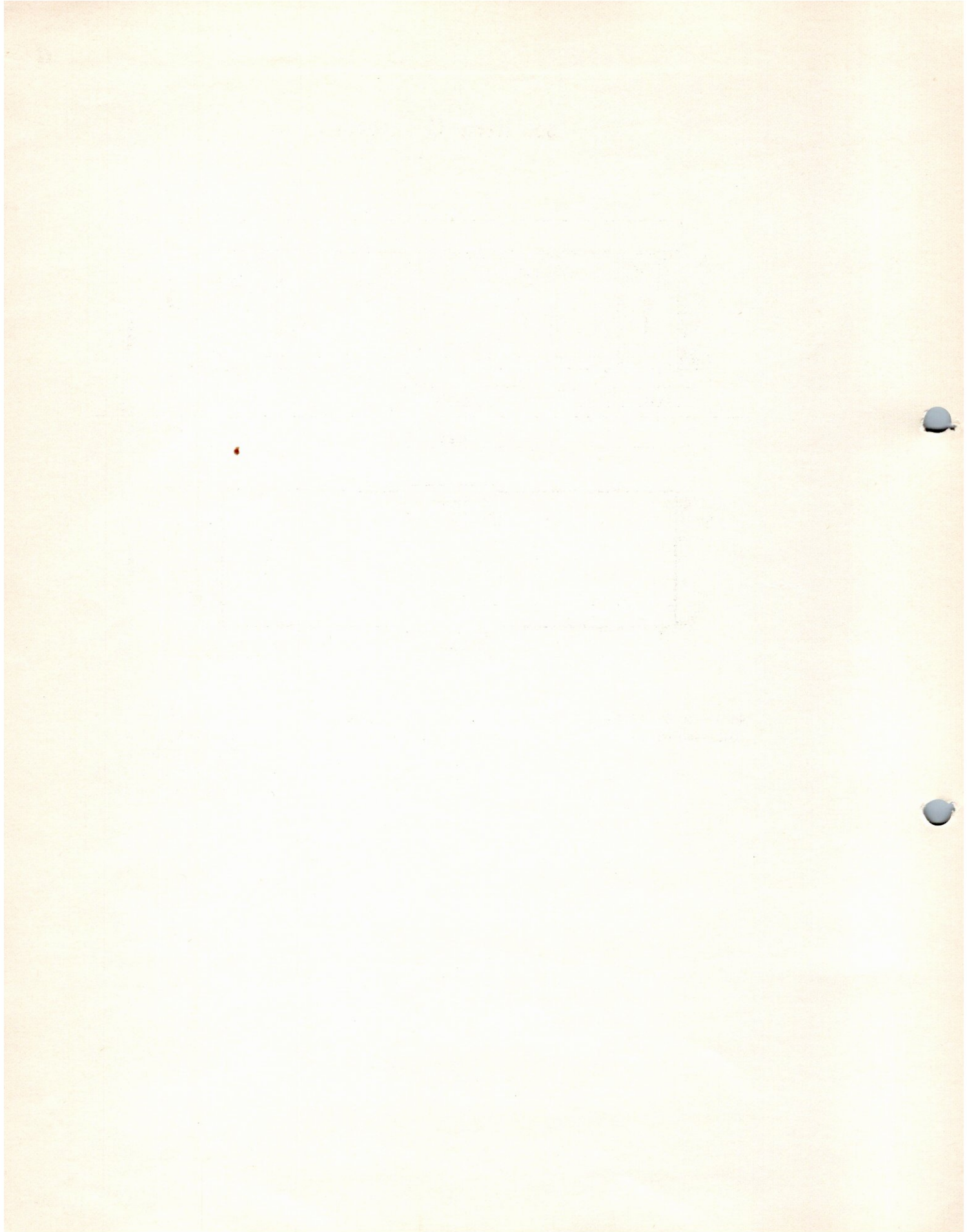

• G<sub>s</sub> 120 1 000-120 1 881

RIV - EUROP

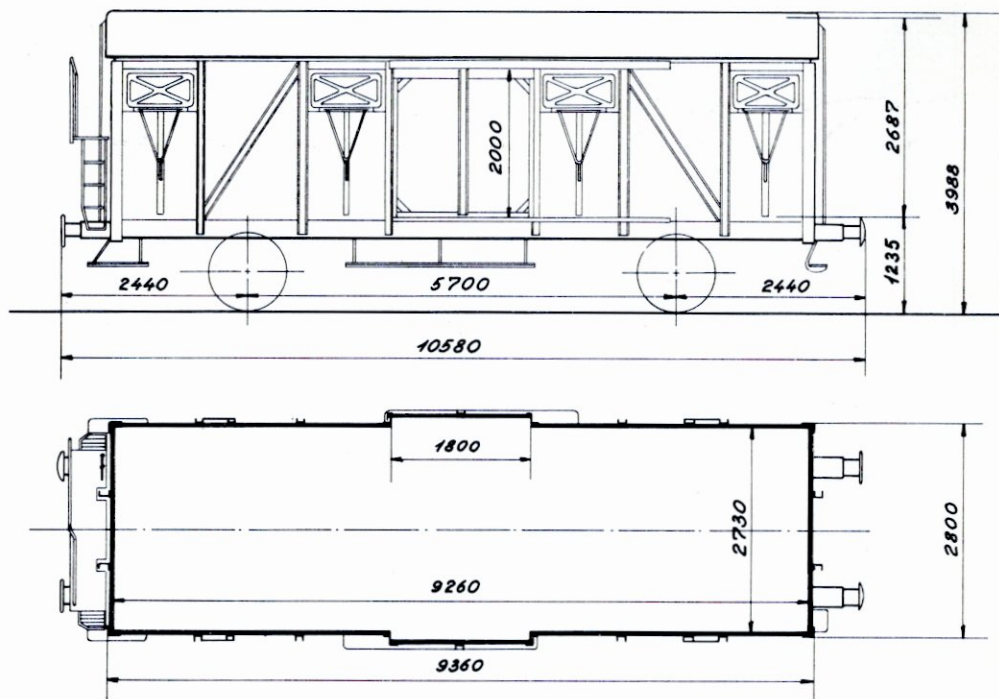

1954/58 Scandia

Bundflade 25,2 m<sup>2</sup>

	A	B	C
	19,5 t	21,0 t	
S	19,5 t	20,0 t	





## Litra Gs

RIV

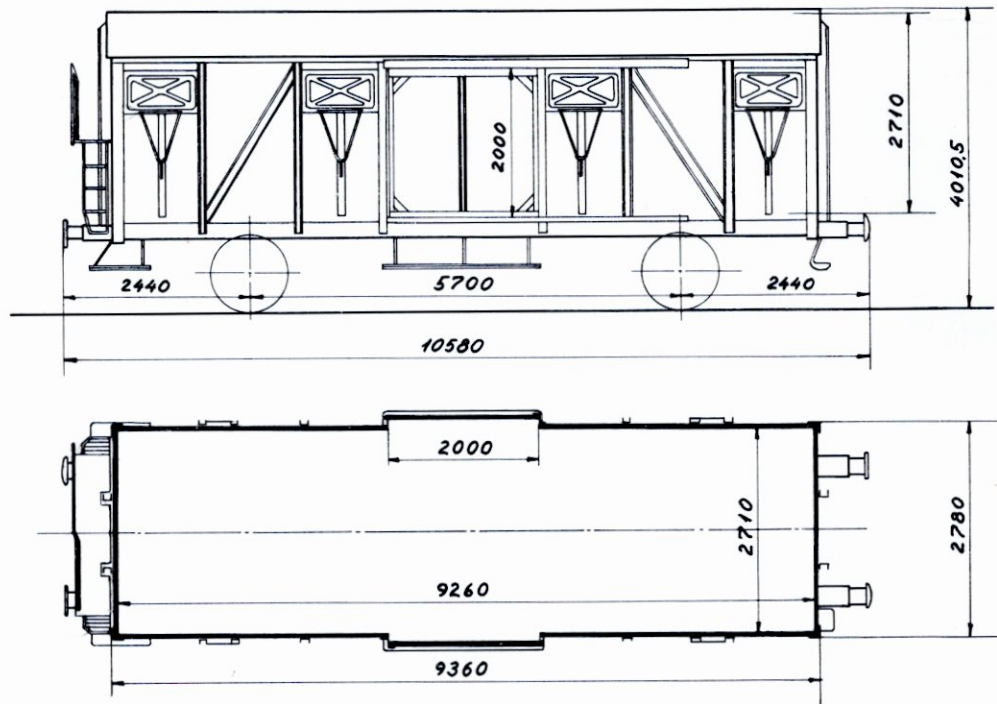

EUROP-mærket

Bundflade 25,0 m<sup>2</sup>

	A	B	C
	19,5 t	23,5 t	27,5 t
S	19,5 t	20,0 t	

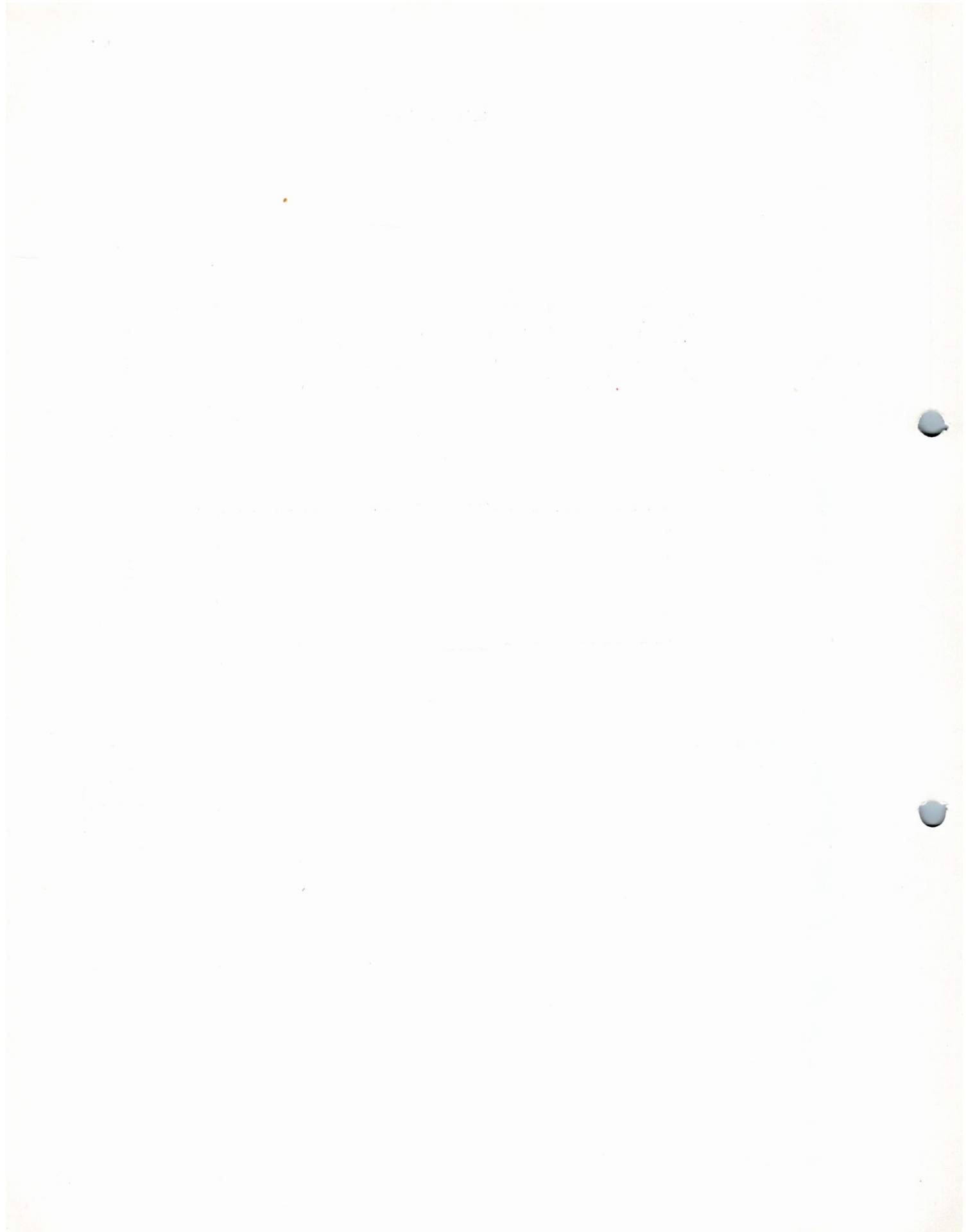

## • Gs 120 2 000 - 120 3 999

RIV - EUROP

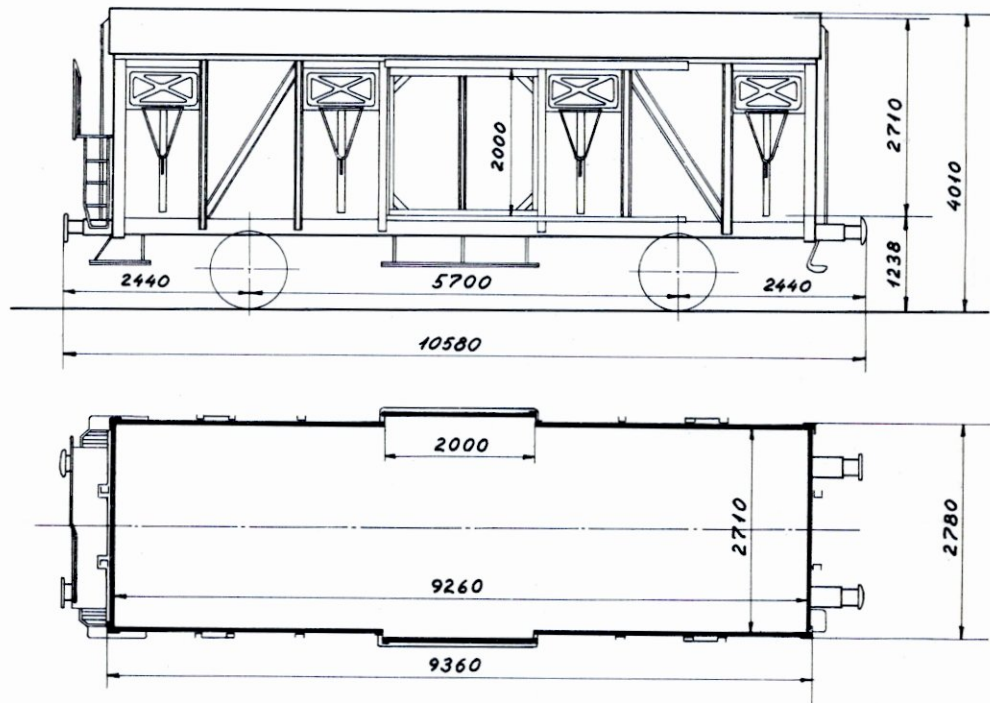

1959/64 Scandia

Bundflade 25,0 m<sup>2</sup>

	A	B	C
	19,5 t	23,5 t	27,5 t
S	19,5 t	20,0 t	

1870-1871



• Gs 123 0 000-123 0 299

RIV - EUROP

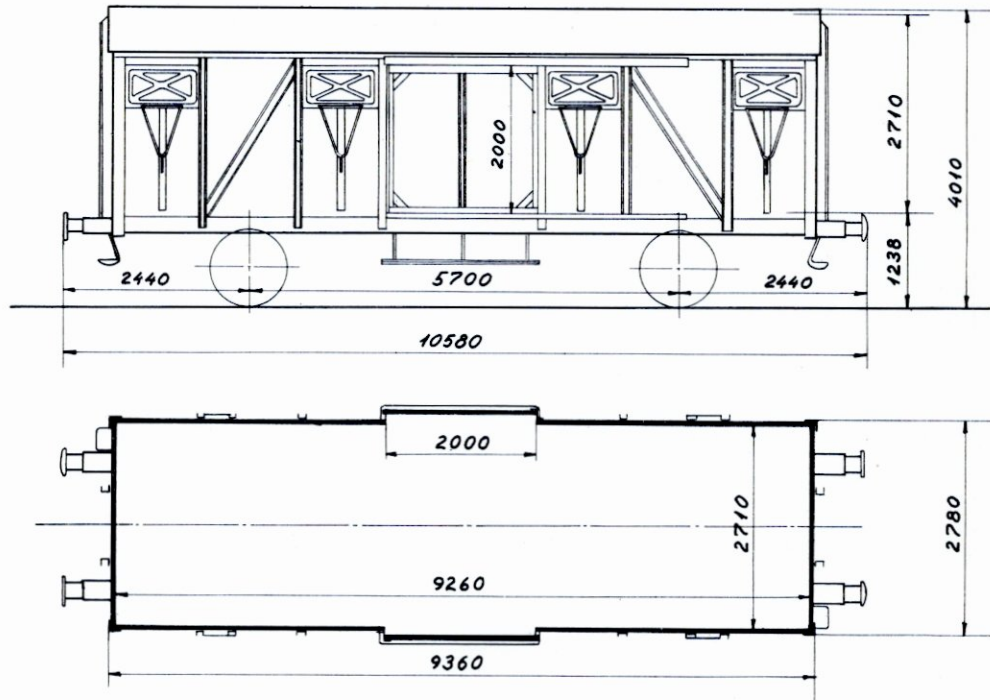

1965/66 Scania

Bundflade 25,0 m<sup>2</sup>

	A	B	C
	20,0 t	24,0 t	28,0 t
S	20,0 t	24,0 t	

1900

1900

1900

1900

1900

1900

1900

1900

1900

1900

1900

1900

1900

1900

1900

1900

1900

## Litra Hs-t

RIV

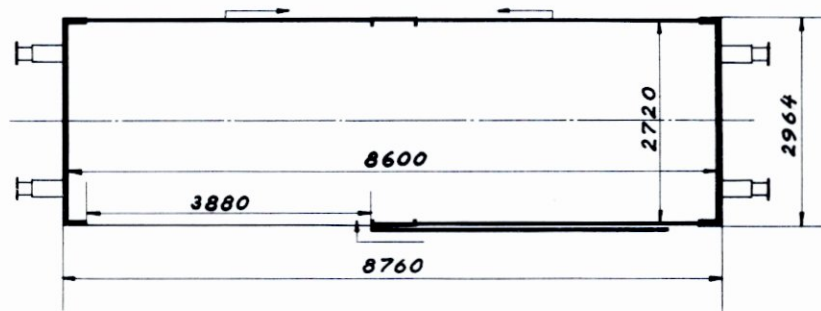
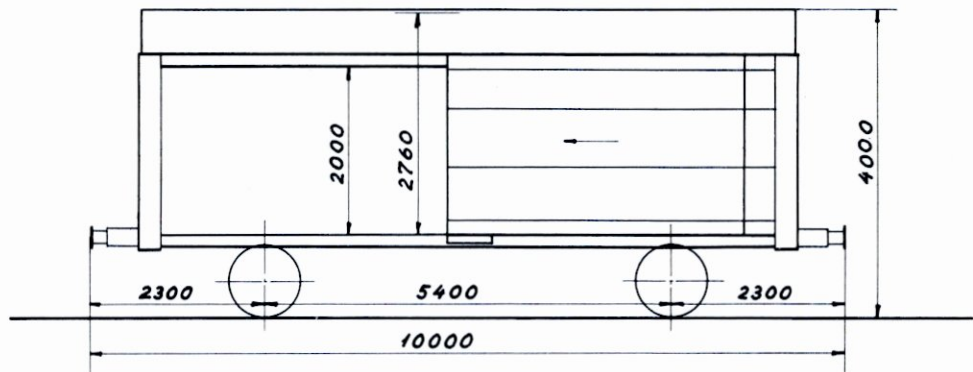
Bundflade 23,8m<sup>2</sup>

	A	B	C
	19,0 t	23,0 t	27,0 t
S	19,0 t	23,0 t	

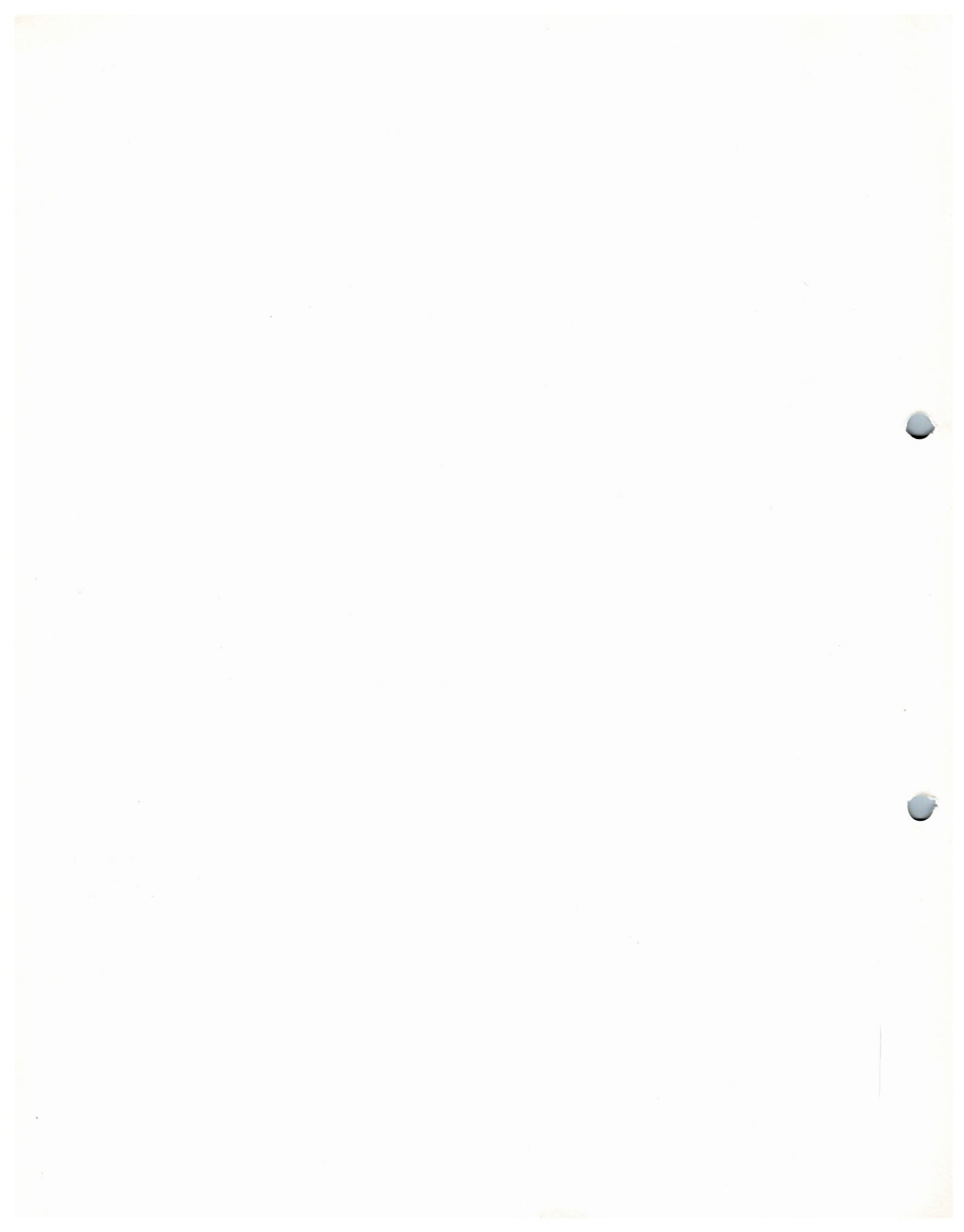



## • His 210 2 990-210 2 999

RIV

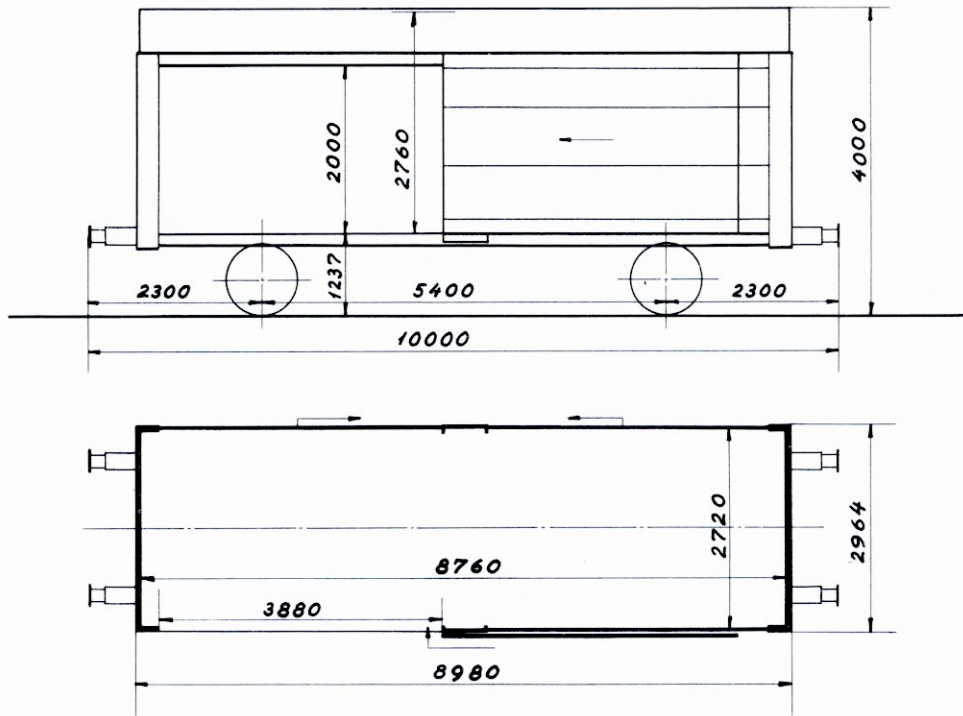

1960 SAEG

Bundflade 23,8 m<sup>2</sup>

	A	B	C
	19,0 t	23,0 t	27,0 t
S	19,0 t	23,0 t	



## Litra Hs-t

RIV

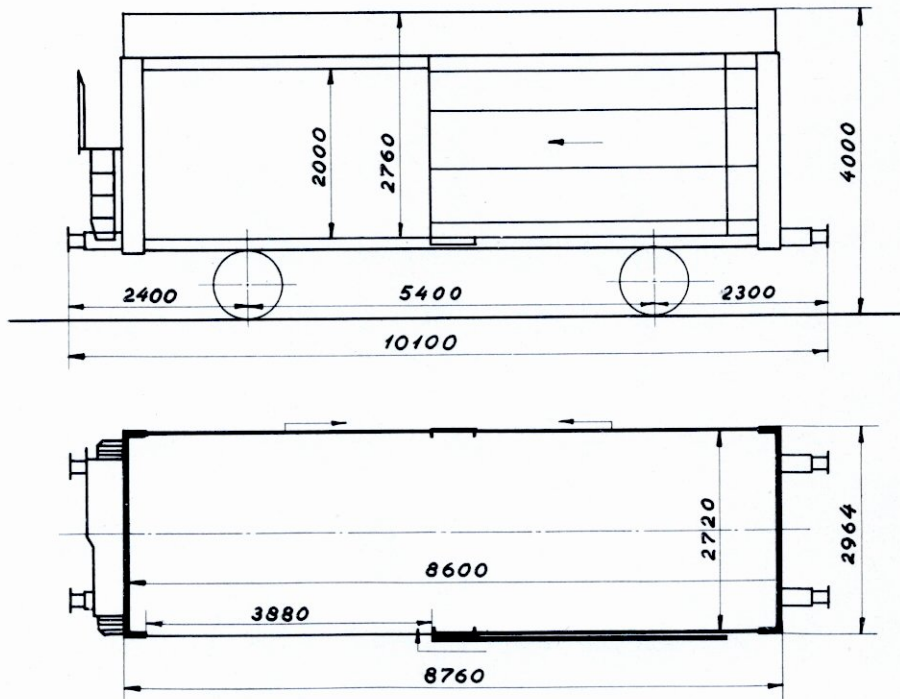
Bundflade 23,8 m<sup>2</sup>

	A	B	C
	19,0 t	23,0 t	27,0 t
S	19,0 t	23,0 t	

Table 1

Year	1980	1981	1982	1983	1984
...	...	...	...	...	...

...

Year	1980	1981	1982	1983	1984
...	...	...	...	...	...

...

...

• His 210 2 000-210 2 599

RIV

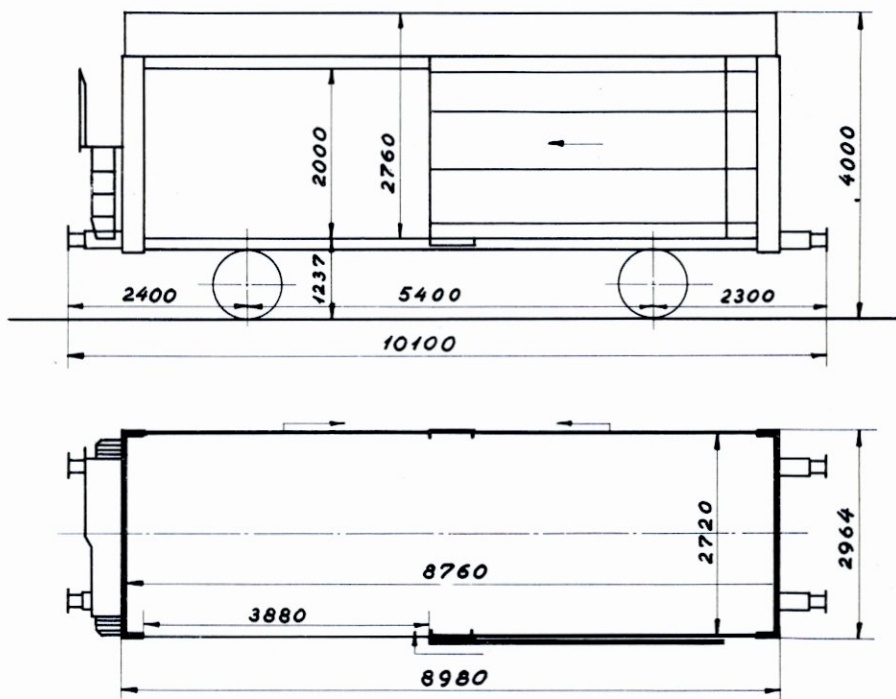

1962/67 Scandia

Bundflade 23,8 m<sup>2</sup>

	A	B	C
	19,0 t	23,0 t	27,0 t
S	19,0 t	23,0 t	



## 803 litra HD nr. 38001—38003, 38005—38274, 38276—38805

RIV

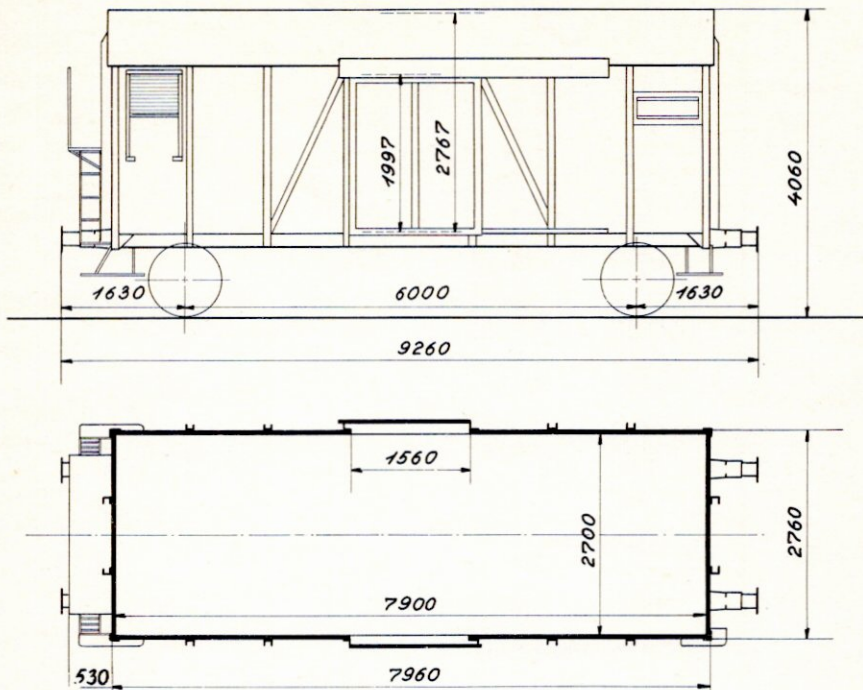

Last 17000 kg  
 Bundfl. 21,3 m<sup>2</sup>  
 Tara ca. 10600 kg  
 Trykluftbr. (G & P)  
 Rangerskruebremse  
 Tyske slutsignalholdere  
 Varmeledning

Nr. 38001—38125	Scandia 1942
„ 38126—38425	„ 1944
„ 38426—38555	„ 1948
„ 38556—38700	„ 1949
„ 38702	„ 1949
„ 38701, 38703—38805	„ 1950

S-mærket  
 Ringfjederpuffere  
 Læsselemme i 2 hjørner

Følgende vogne er EUROP-mærket:  
 38414, 38495—38514, 38525—38805

THE UNIVERSITY OF CHICAGO

PHYSICS DEPARTMENT

1954

1955

1956

1957

1958

1959

1960

1961

1962

1963

1964

1965

1966

1967

1968

1969

1970

1971

1972

1973

1974

1975

1976

1977

1978



• Gklms 138 8 000-138 8 804

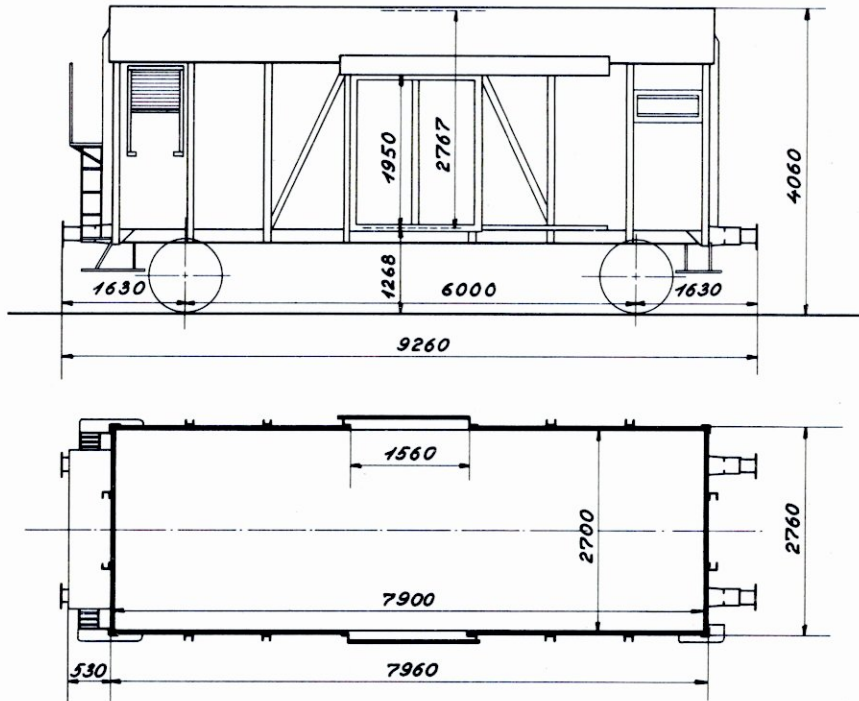

1942/50 Scandia

Bundflade 21,3 m<sup>2</sup>

	A	B	C
		17,5 t	
S		17,5 t	

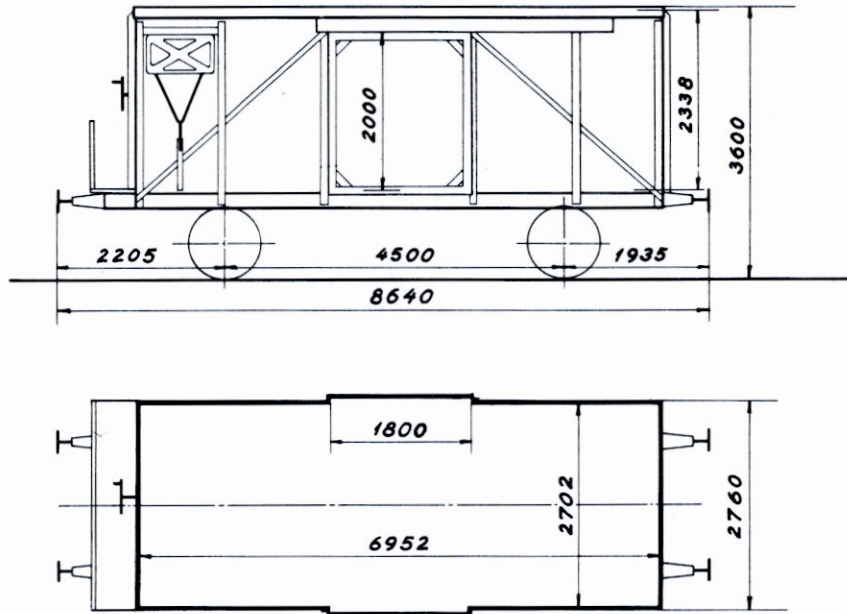

## Litra Hj

Bundflade 18,8 m<sup>2</sup>

A	B	C
15,5 t	15,5 t	

1891

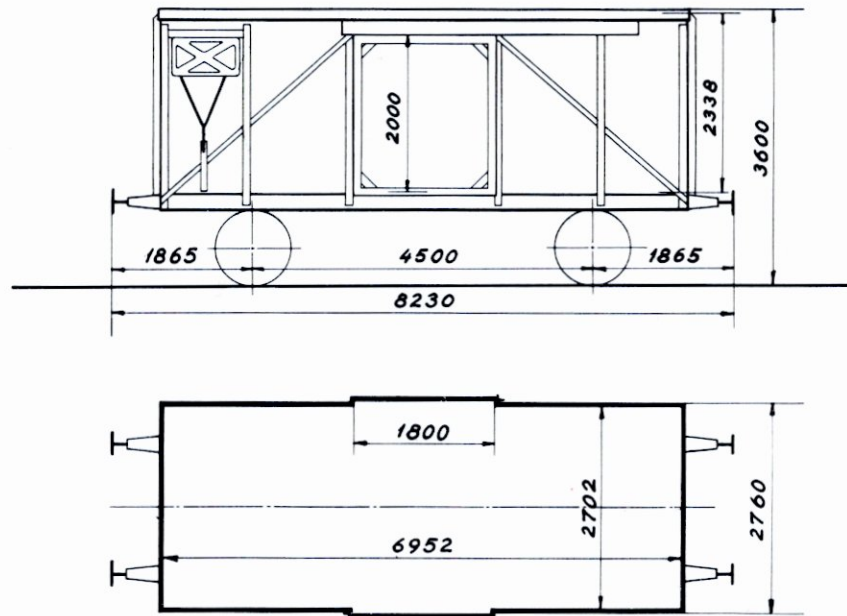

## Litra Hj

Bundflade 18,8 m<sup>2</sup>

A	B	C
15,5 t	15,5 t	



## 1 litra Hj nr. 37001

RIV

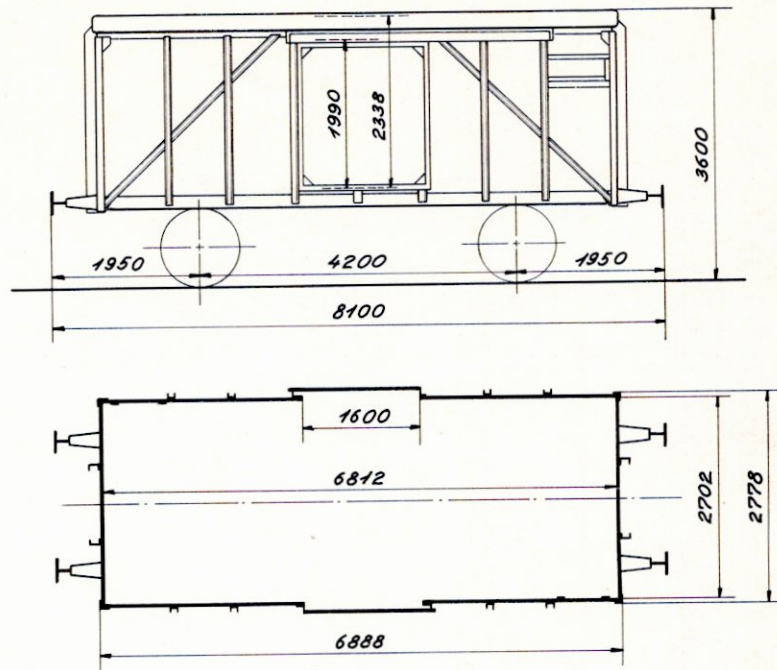

1922. Scandia  
Ombygget 1956. København

Last 15000 kg  
Bundflade 18,4 m<sup>2</sup>  
Tara ca. 8600 kg  
Trykluftledning  
Håndbremse

## 1 litra HJ nr. 37601

RIV

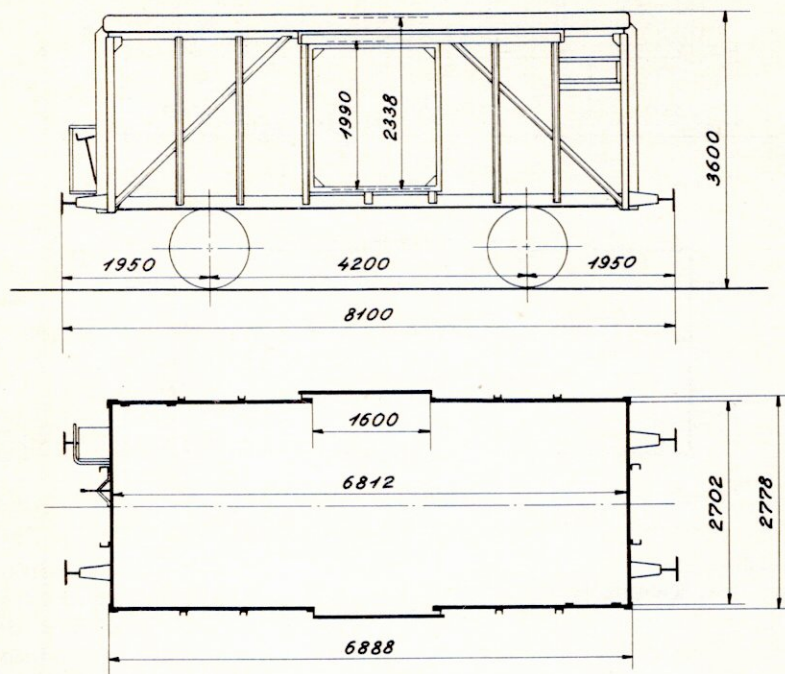

1924. Scandia  
Ombygget 1956. Aarhus

Last 15000 kg  
Bundflade 18,4 m<sup>2</sup>  
Tara ca. 9200 kg  
Trykluftbremse (G)  
Rangerskruebremse



**130 litra IA** nr. 19001—19130  
RIV

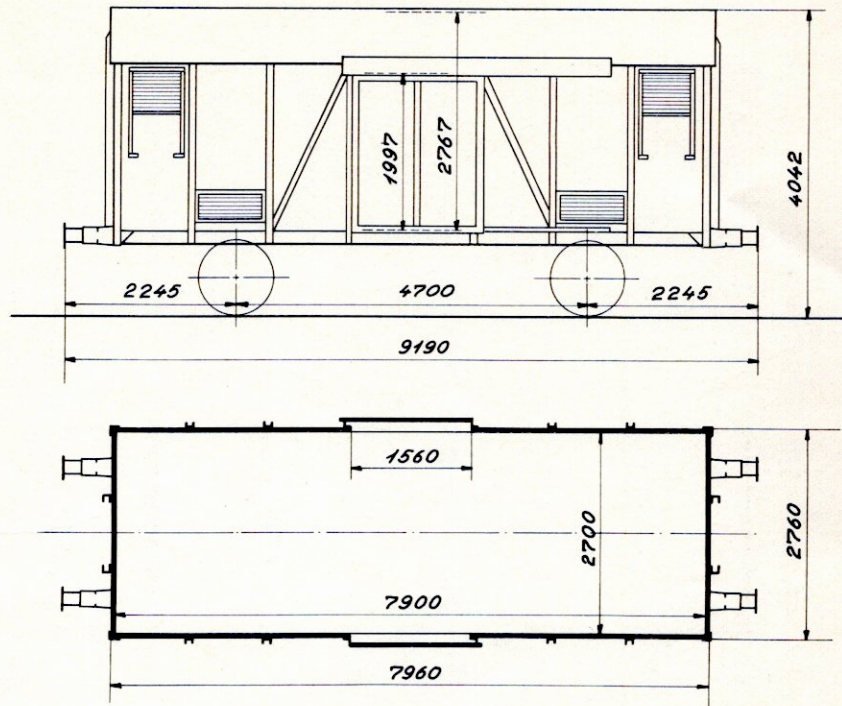

1931. Scandia

Hvidmalede  
Cylinderpuffere

Last 17000 kg  
Bundflade 21.3 m<sup>2</sup>  
Tara ca. 12400 kg  
Trykluftbremse (G)  
Håndbremse

**369 litra IAL** nr. 19131—19284, 19286—19500

RIV

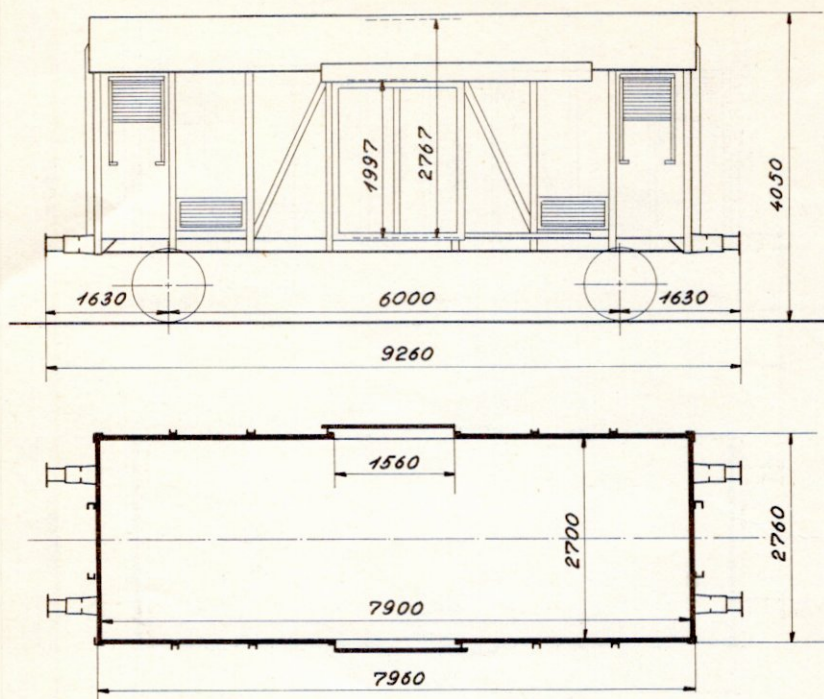

19131—19200. 1940. Scandia  
19201—19500. 1941, „

S-mærket  
Hvidmalede  
Cylinderpuffere  
Anvendes til transport af æg

Last 17000 kg  
Bundflade 21,3 m<sup>2</sup>  
Tara ca. 10800 kg  
Trykluftbremse (G-P)  
Håndbremse  
Varmeledning

Nr. 19210 og 19421 er udlejet til Dansk Andels Ørredeksport  
og har midlertidig litra ZF nr. 500071 og 500073.  
„ 19181 „ „ „ Dänische Forellen Producenten  
og har midlertidig litra ZF nr. 500101

50 **litra IAL** nr. 19501, 19502, 19503, 19504, 19505, 19506, 19507, 19508, 19509, 19510, 19511, 19512, 19513, 19514, 19515, 19516, 19517, 19518, 19519, 19520, 19521, 19522, 19523, 19524, 19525, 19526, 19527, 19528, 19529, 19530, 19531, 19532, 19533, 19534, 19535, 19536, 19537, 19538, 19539, 19540, 19541, 19542, 19543, 19544, 19545, 19546, 19547, 19548, 19549, 19550.

RIV

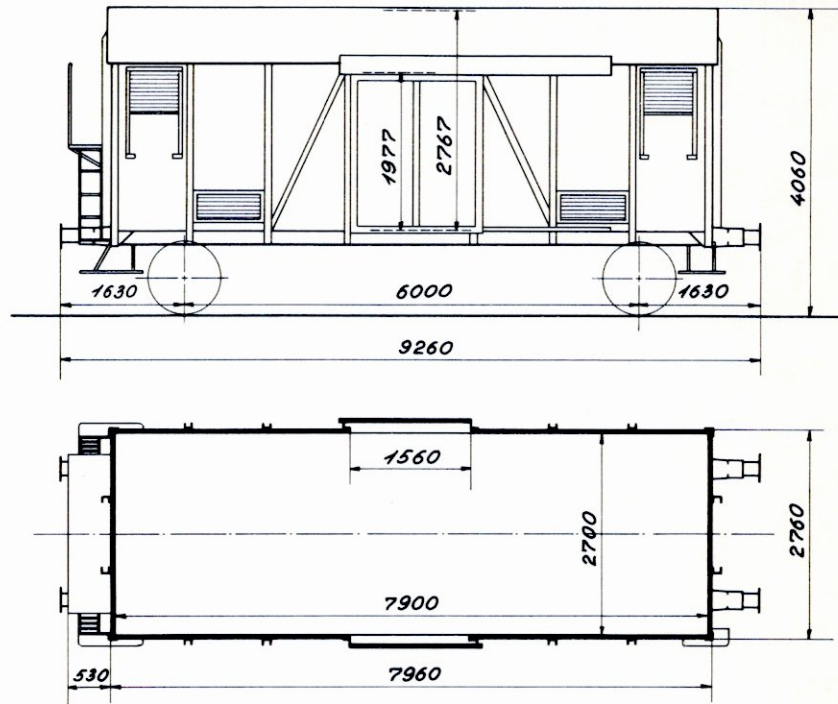

1950. Scania

S-mærket  
Hvidmalede  
Ringfjederpuffere  
Fortrinsvis til transport af æg

Last 17000 kg  
Bundflade 21,3 m<sup>2</sup>  
Tara ca. 10800 kg  
Trykluftbremse (G-P)  
Rangerskruebremse  
Varmeledning

Nr. 19545 er udlejet til P. Holm Nyland og har midlertidig litra ZF nr. 500045

250 **litra IAK** nr. 21001, 21002, 21003, 21004, 21005, 21006, 21007, 21008, 21009, 21010, 21011, 21012, 21013, 21014, 21015, 21016, 21017, 21018, 21019, 21020, 21021, 21022, 21023, 21024, 21025, 21026, 21027, 21028, 21029, 21030, 21031, 21032, 21033, 21034, 21035, 21036, 21037, 21038, 21039, 21040, 21041, 21042, 21043, 21044, 21045, 21046, 21047, 21048, 21049, 21050, 21051, 21052, 21053, 21054, 21055, 21056, 21057, 21058, 21059, 21060, 21061, 21062, 21063, 21064, 21065, 21066, 22067, 21068, 21069, 21070, 21071, 21072, 21073, 21074, 21075, 21076, 21077, 21078, 21079, 21080, 21081, 21082, 21083, 21084, 21085, 21086, 21087, 21088, 21089, 21090, 21091, 21092, 21093, 21094, 21095, 21096, 21097, 21098, 21099, 21100, 21101, 21102, 21103, 21104, 21105, 21106, 21107, 21108, 21109, 21110, 21111, 21112, 21113, 21114, 21115, 21116, 21117, 21118, 21119, 21120, 21121, 21122, 21123, 21124, 21125, 21126, 21127, 21128, 21129, 21130, 21131, 21132, 21133, 21134, 21135, 21136, 21137, 21138, 21139, 21140, 21141, 21142, 21143, 21144, 21145, 21146, 21147, 21148, 21149, 21150, 21151, 21152, 21153, 21154, 21155, 21156, 21157, 21158, 21159, 21160, 21161, 21162, 21163, 21164, 21165, 21166, 21167, 21168, 21169, 21170, 21171, 21172, 21173, 21174, 21175, 21176, 21177, 21178, 21179, 21180, 21181, 21182, 21183, 21184, 21185, 21186, 21187, 21188, 21189, 21190, 21191, 21192, 21193, 21194, 21195, 21196, 21197, 21198, 21199, 21200, 21201, 21202, 21203, 21204, 21205, 21206, 21207, 21208, 21209, 21210, 21211, 21212, 21213, 21214, 21215, 21216, 21217, 21218, 21219, 21220, 21221, 21222, 21223, 21224, 21225, 21226, 21227, 21228, 21229, 21230, 21231, 21232, 21233, 21234, 21235, 21236, 21237, 21238, 21239, 21240, 21241, 21242, 21243, 21244, 21245, 21246, 21247, 21248, 21249, 21250.

## RIV

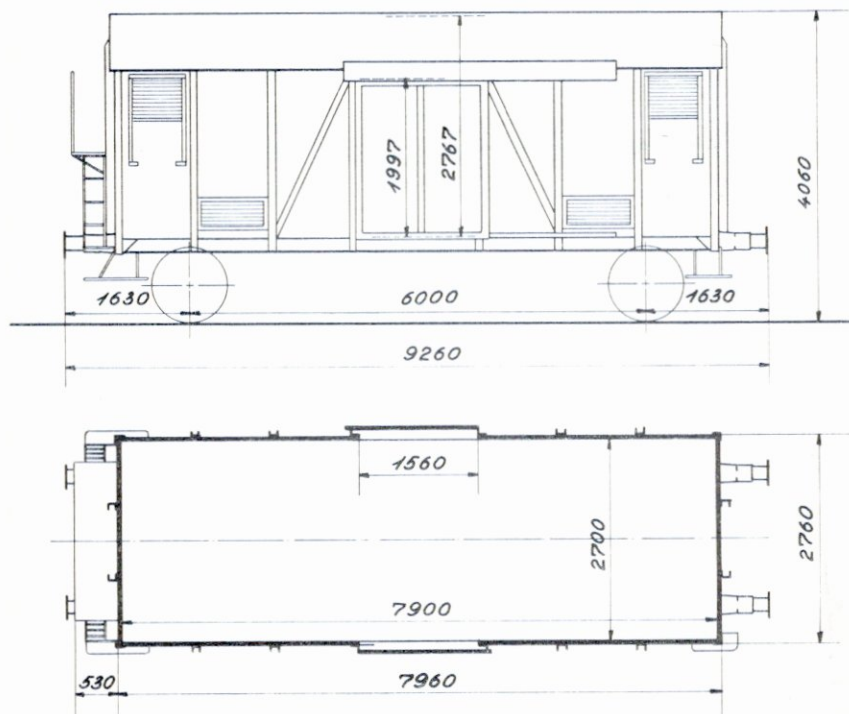

21001—21050. 1944 Scandia  
 21051—21225. 1944—1945 »  
 21226—21250. 1946—1947 »

S-mærket  
 Hvidmalede  
 Vognene er forsynet med  
 18 bærestænger og 162 kødkroge  
 og skal fortrinsvis benyttes til  
 transport af kød  
 Ringfjederpuffere

Last 17000 kg  
 Bundflade 21,3 m<sup>2</sup>  
 Tara ca. 11600 kg  
 Trykluftbremse (G-P)  
 Rangskruerbremse  
 Varmeledning

## Litra IAR

RIV

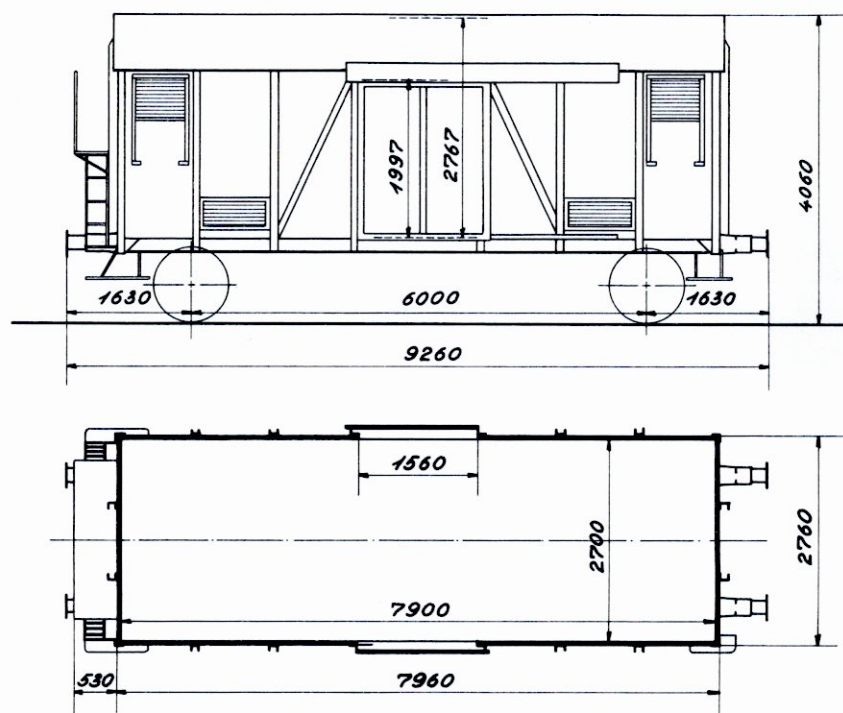
Bundflade 21,3 m<sup>2</sup>

	A	B	C
	17,5 t	17,5 t	
S	17,0 t		



60 **Litra I** nr. 21501—21560

RIV

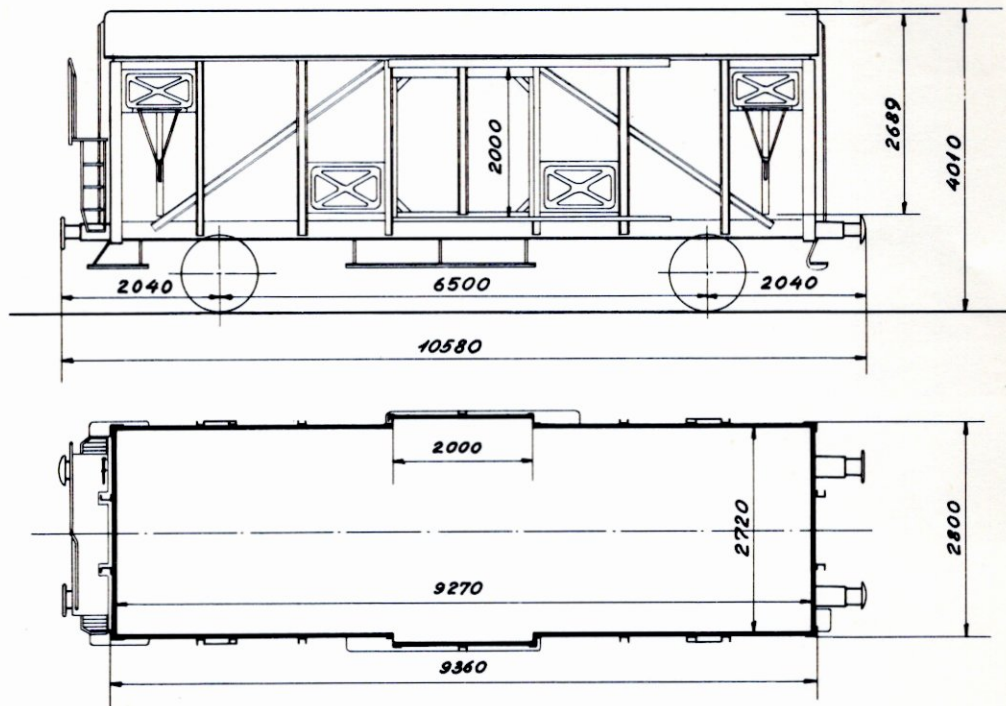

1958 Scandia

S-mærket

Hvidmalede  
Ringfjederpuffere

Max. last 21000 kg  
Bundflade 25,2 m<sup>2</sup>  
Tara ca. 12500 kg  
Trykluftbremse (G-P)  
Rangerskruebremse

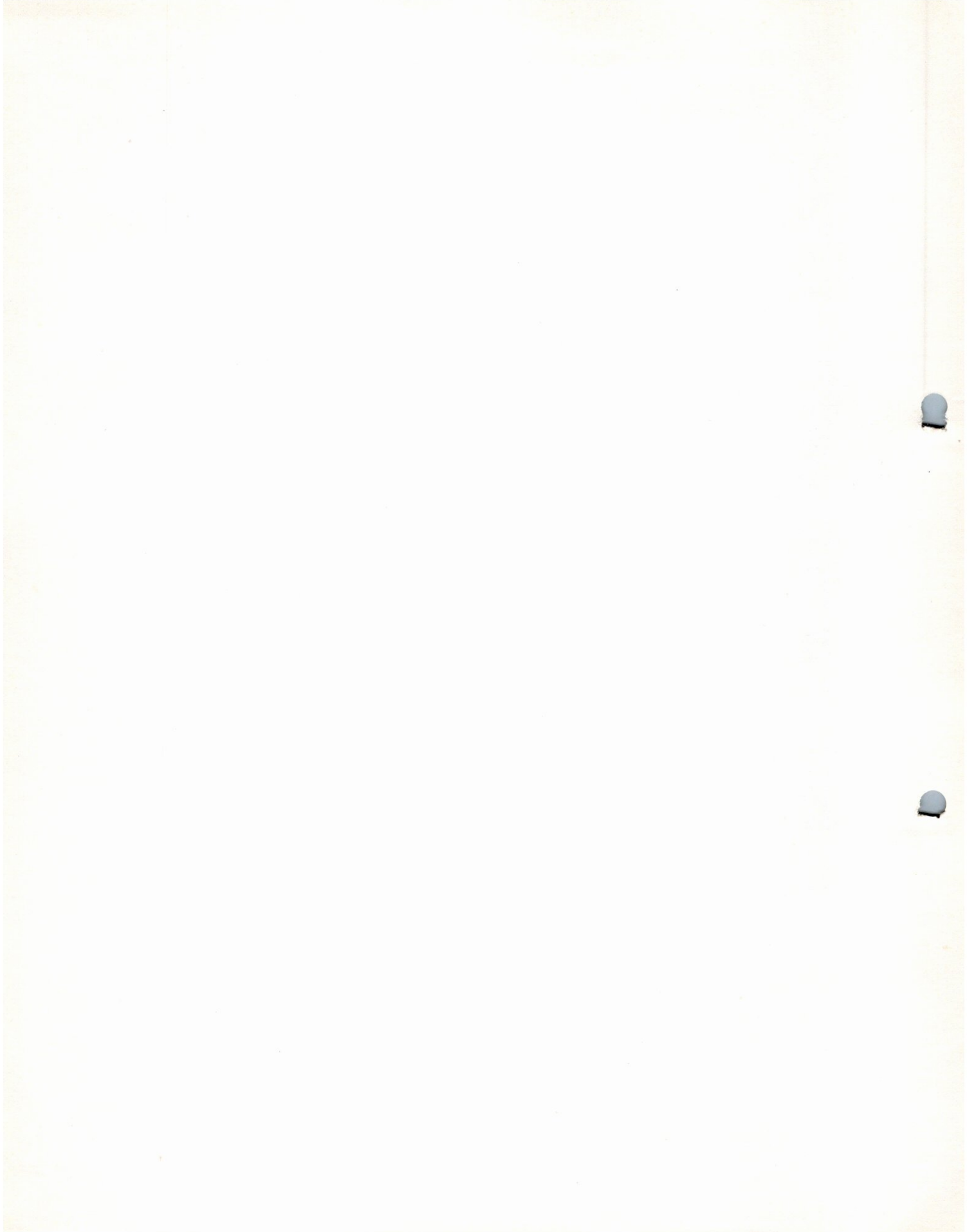

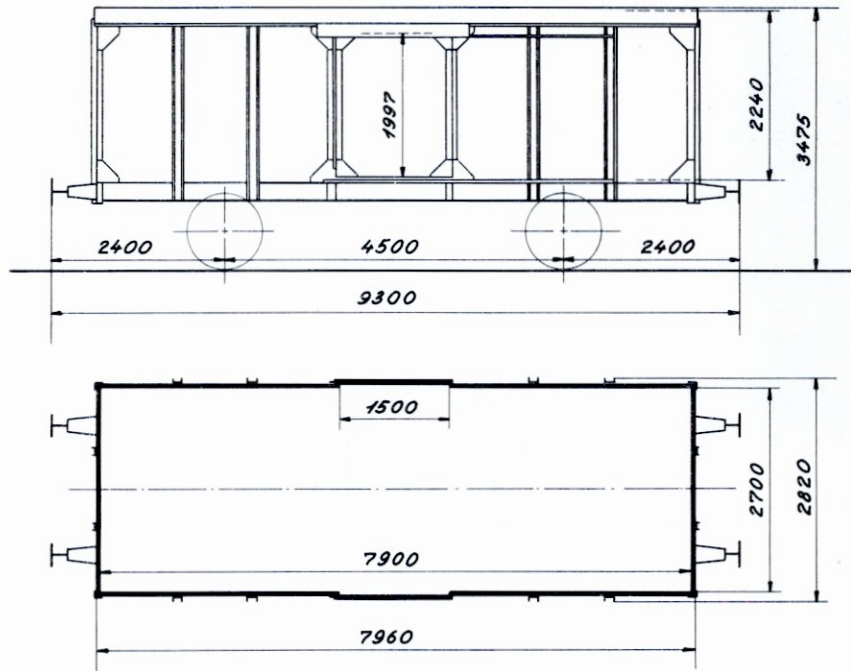

## Litra IE

Bundflade 21,3 m<sup>2</sup>

A	B	C
15,5 t		15,5 t

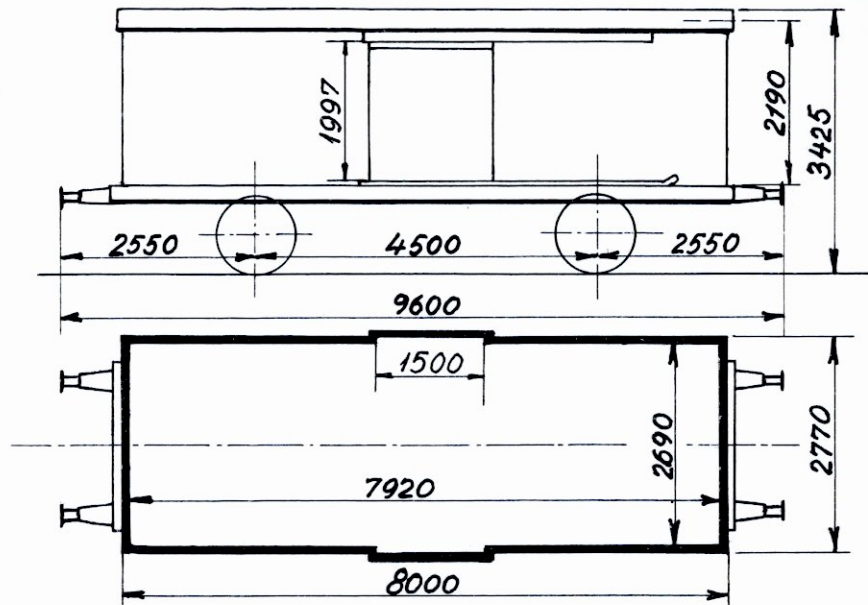

## Litra IE

Bundflade 21,3 m<sup>2</sup>

A	B	C
15,5 t		15,5 t

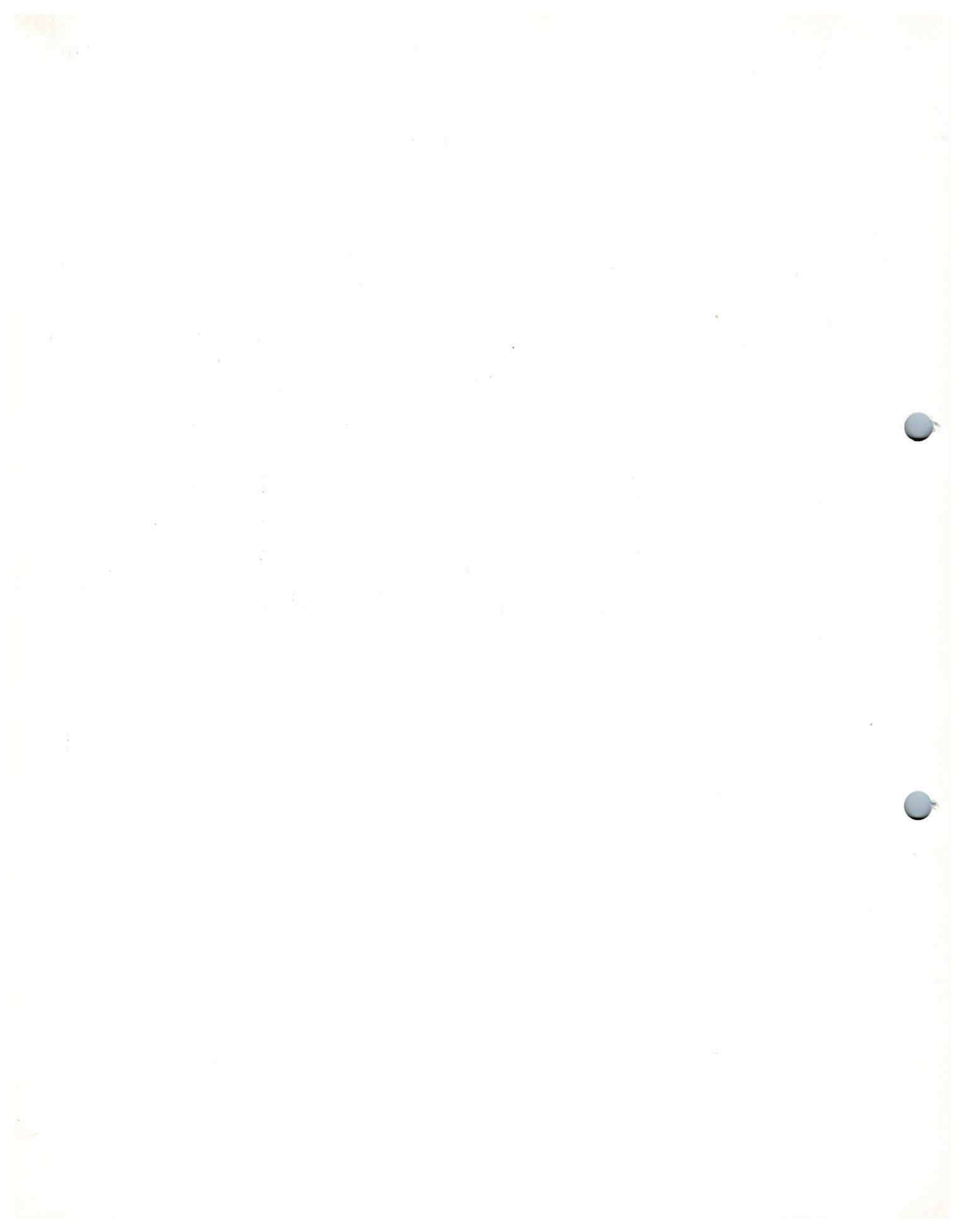

- Hks 215 0 800-215 0 849
- Hkrs 215 6 000-215 6 049

RIV

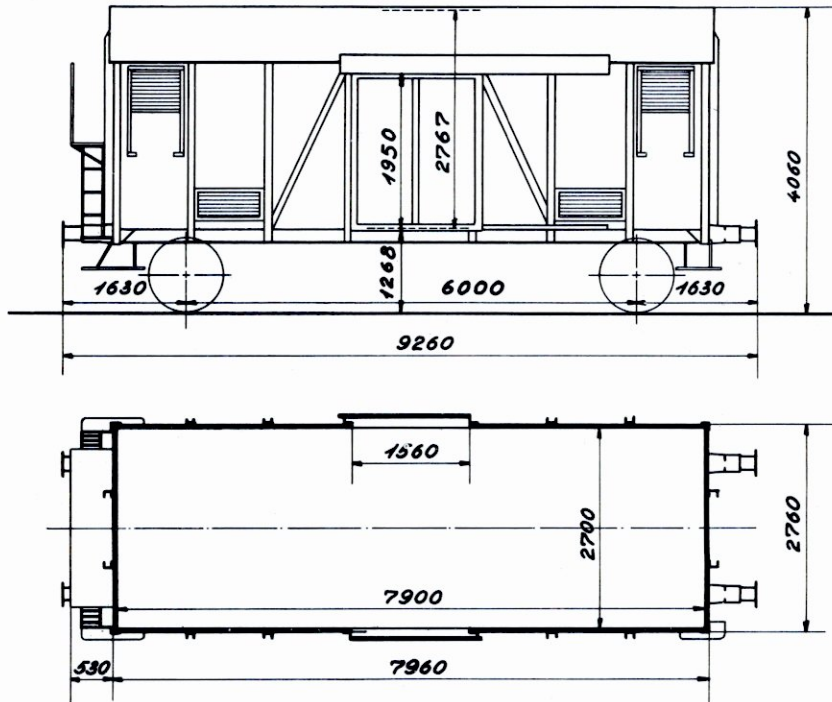

1946/47 Scandia

Hvidmalet

Bundflade 21,3 m<sup>2</sup>

	A	B	C
	17,5 t		
S	17,5 t		

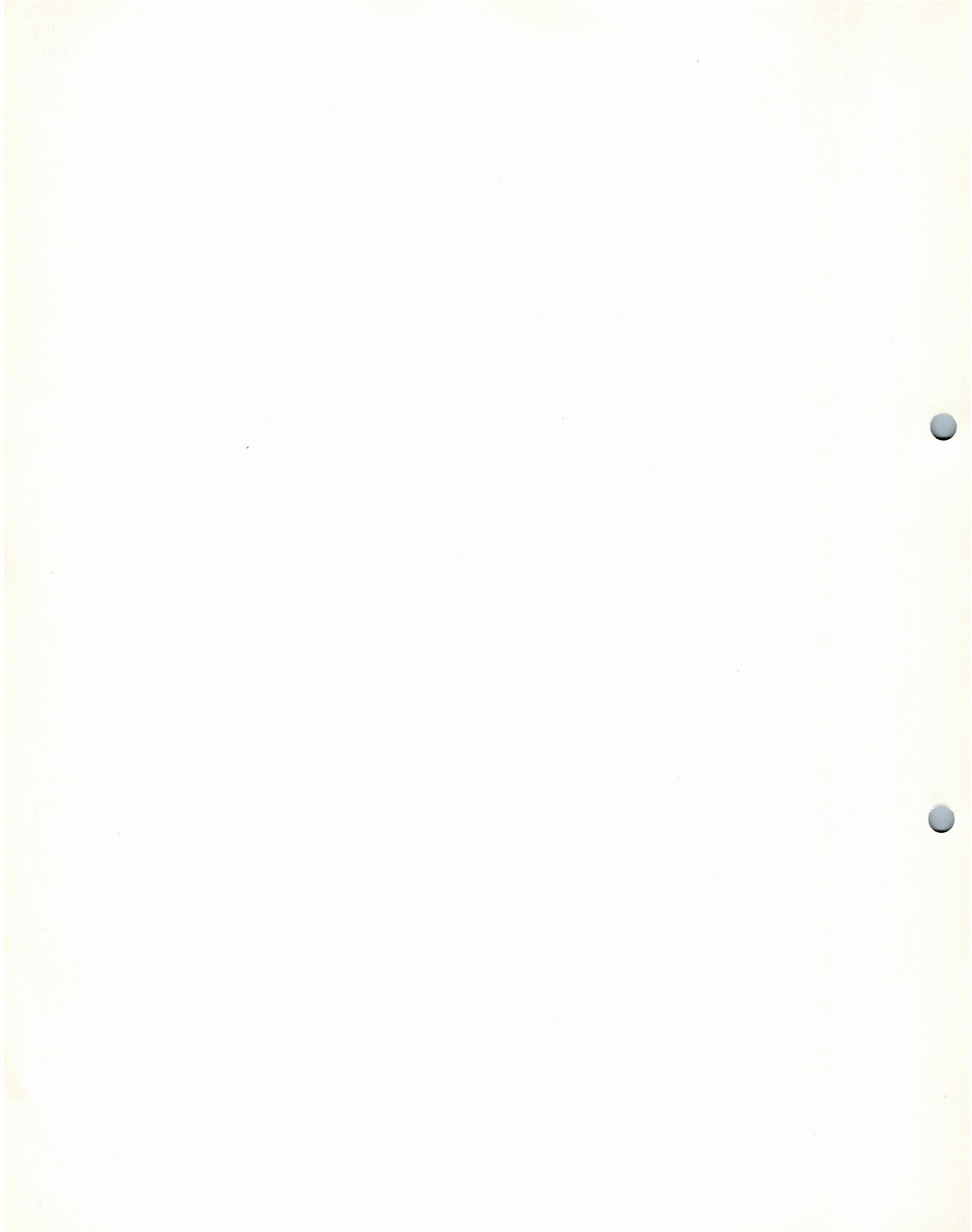

• Hks-u 215 0 000 - 215 0 099

RIV

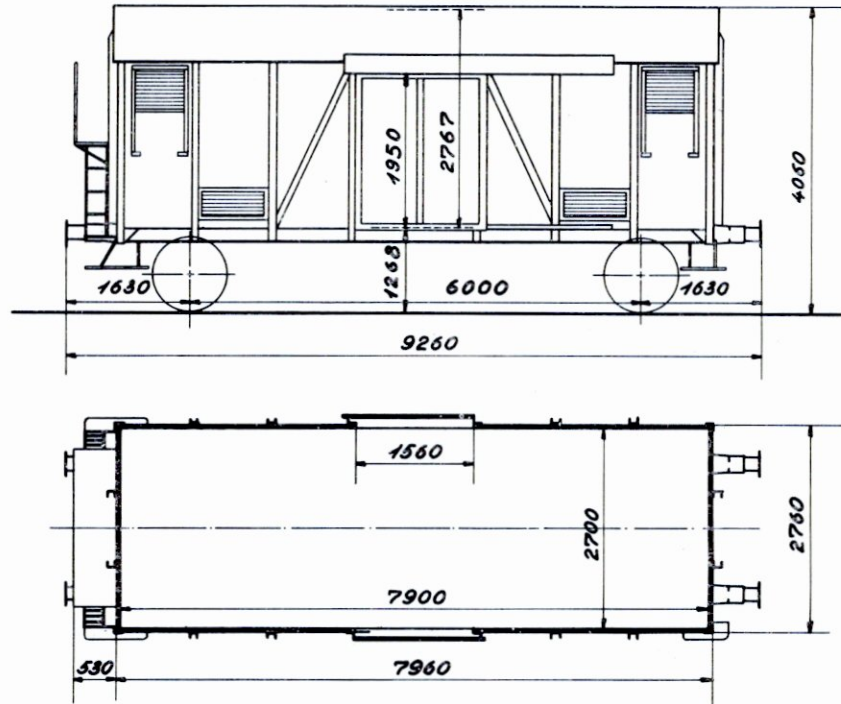

1942/46 Scandia

Hvidmalet kødvogn

Bundflade 21,3 m<sup>2</sup>

A	B	C
17,5 t		
S	17,5 t	





· Hks-v 215 0 500 - 215 0 669

RIV

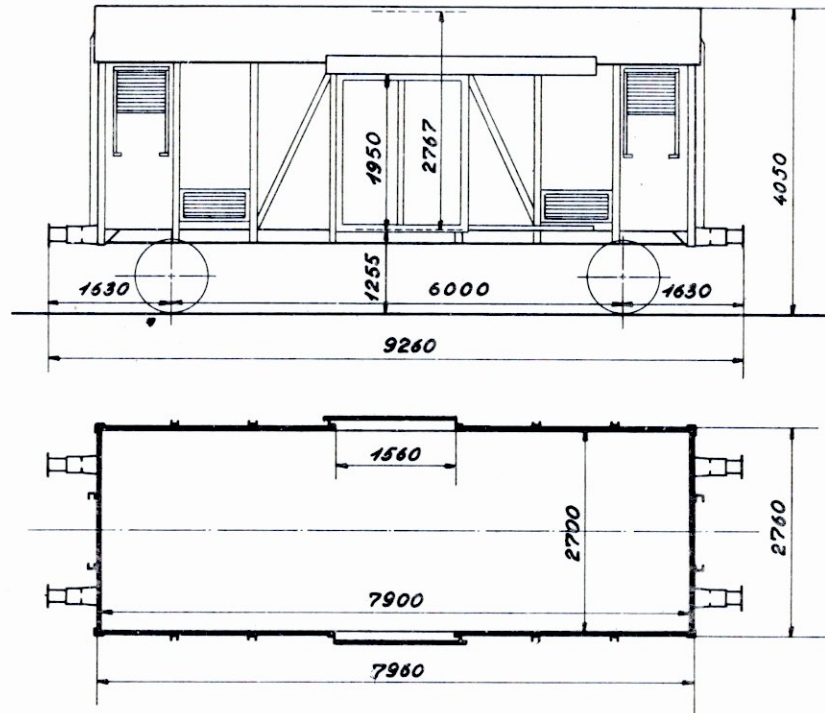

1941 Scandia

Hvidmalet ægvogn

Bundflade 21,3 m<sup>2</sup>

	A	B	C
		17,5 t	
S		17,5 t	



• Hks-v 215 0 700 - 215 0 749

RIV

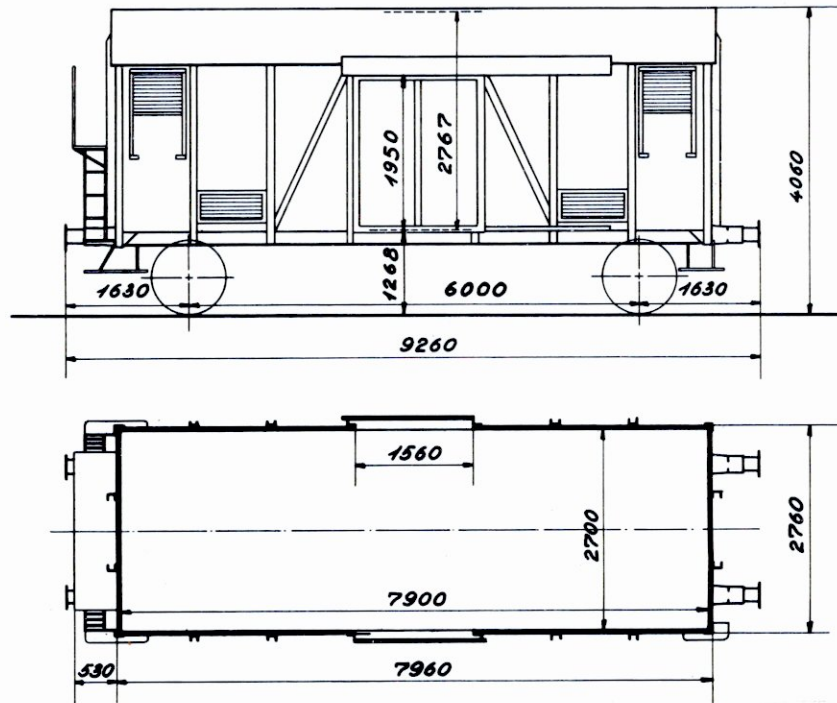

1950 Scandia

Hvidmalet ægvogn

Bundflade 21,3 m<sup>2</sup>

	A	B	C
		17,5 t	
S		17,5 t	



## . Hs 210 0 000-210 0 199

RIV

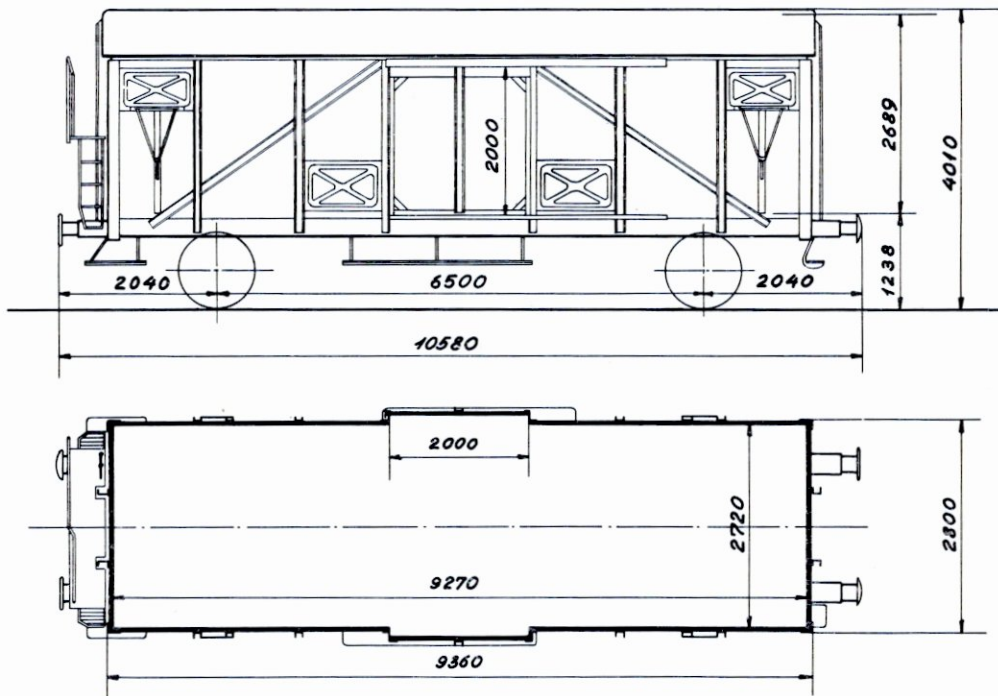

1958/59 Scania

Hvidmalet

Bundflade 25,2 m<sup>2</sup>

	A	B	C
	19,5 t	21,0 t	
S	19,5 t	20,0 t	

1880 - 1881



**.Hs 210 0 096, 210 0 131, 210 0 153, 210 0 153.**

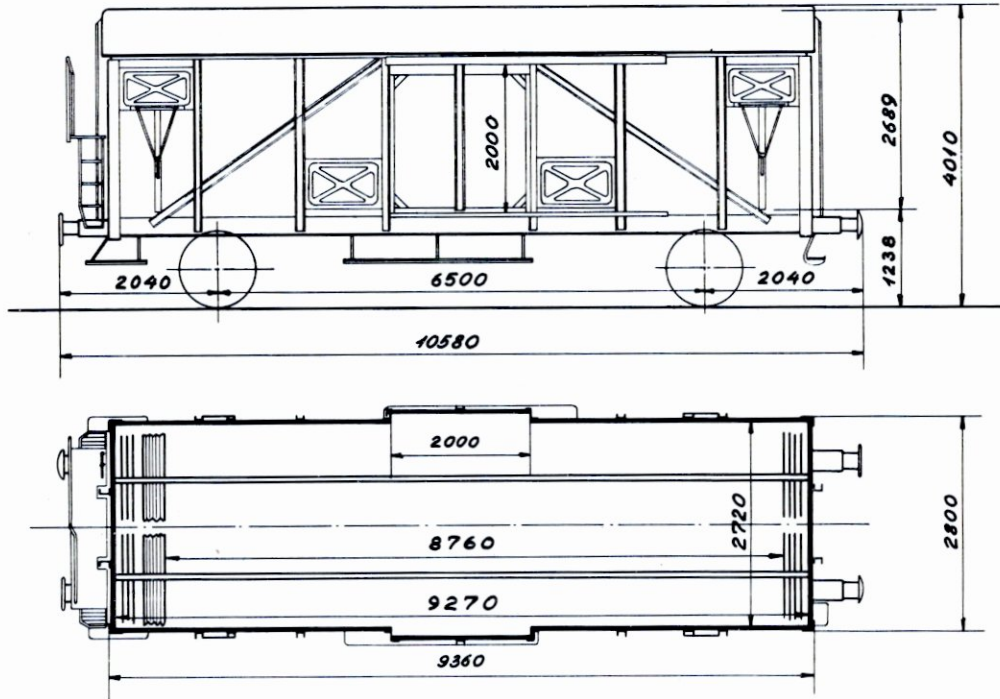

Scania 1959

Hvidmalet

Bundflade 23,8 m<sup>2</sup>

	A	B	C
	18,5t	20,0t	
S	18,5t	19,0t	





# Litra Ib

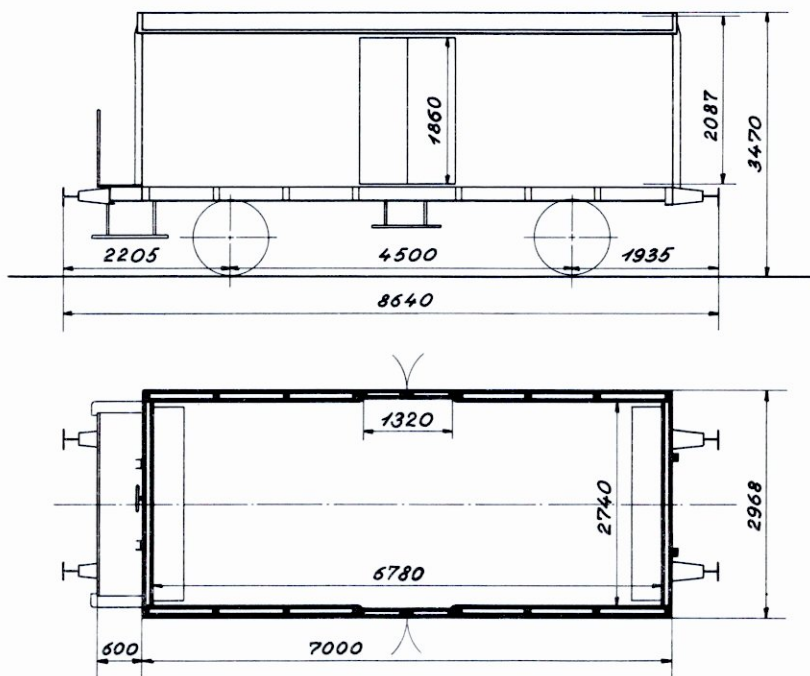

Bundflade 14,5-18,6 m<sup>2</sup>

	A	B	C
	15,5 t	15,5 t	
S	14,0 t		



# Litra IF

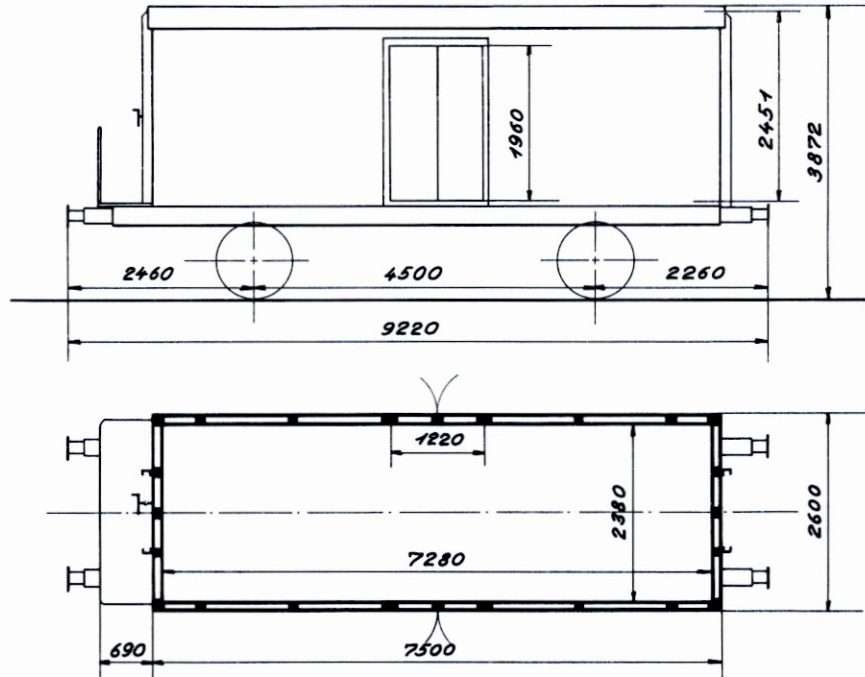

Bundflade 17,3 m<sup>2</sup>

A	B	C
14,0 t		14,0 t



Litra Ig  
Litra Igk

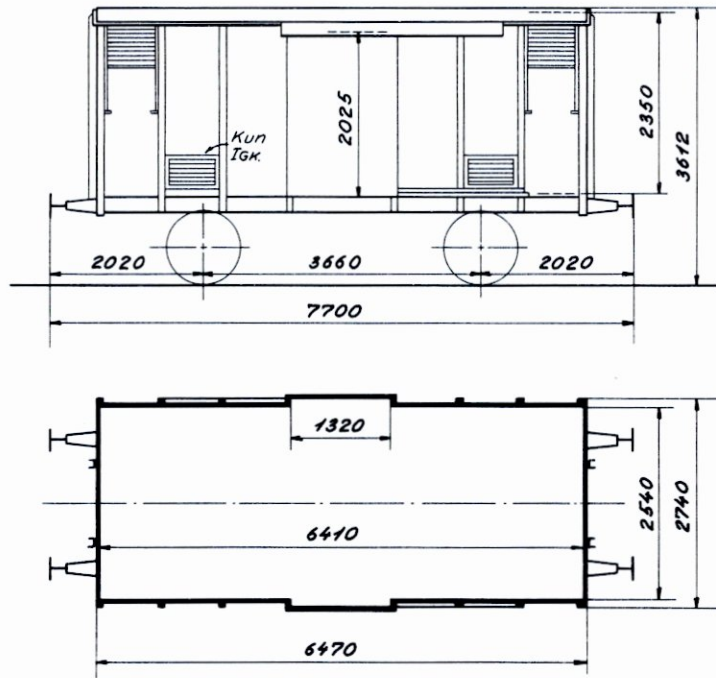

Bundflade 16,3 m<sup>2</sup>

A	B	C
13,0 t	13,0 t	

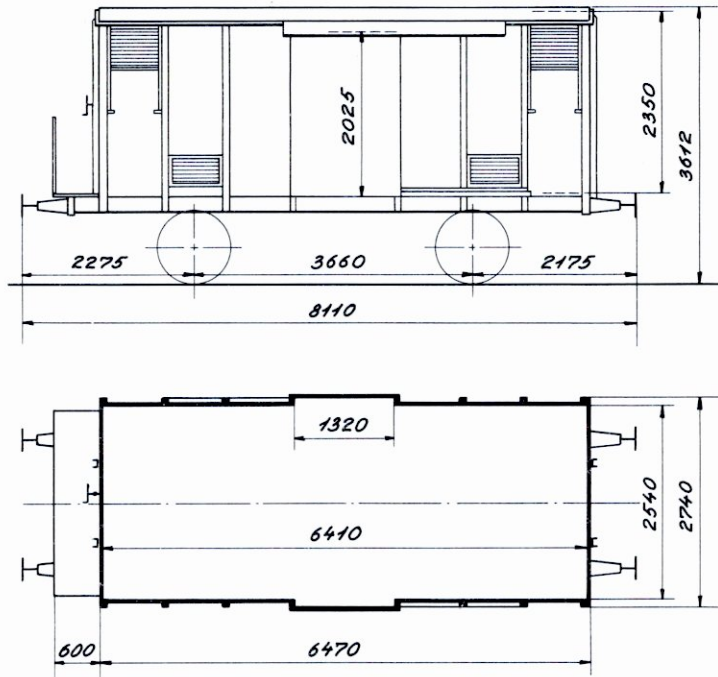

## Litra IGK

Bundflade 16,3 m<sup>2</sup>

A	B	C
13,0 t	13,0 t	





# Litra IKA

RIV  
INTERFRIGO

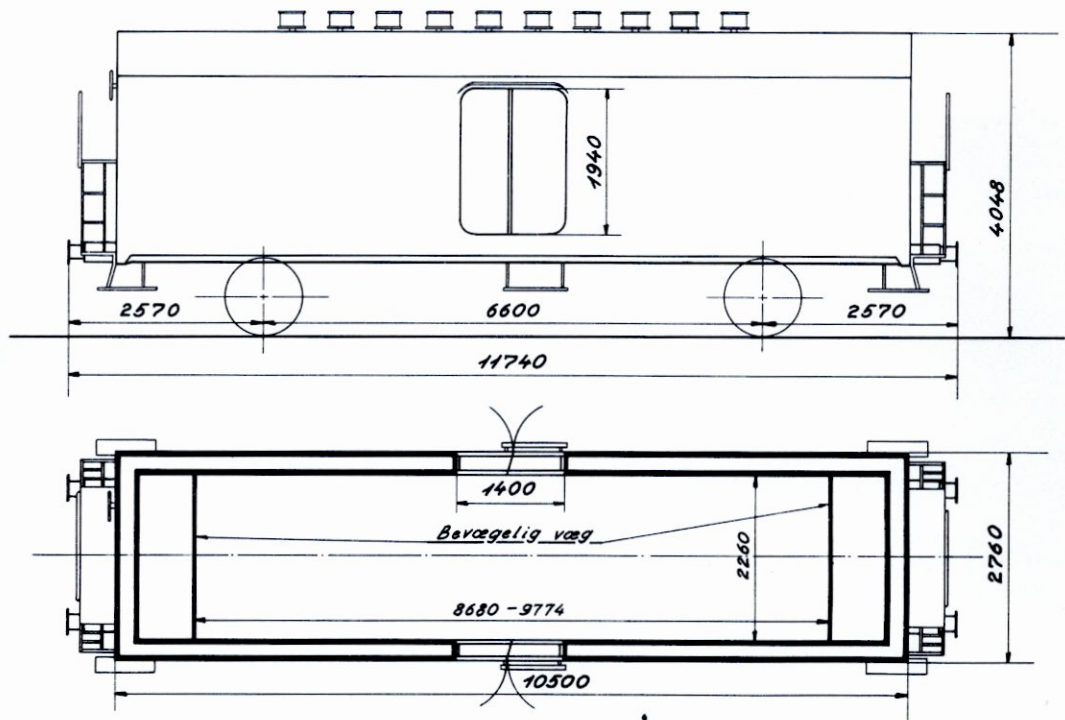

Bundflade maks. 22,1 m<sup>2</sup>

	A	B	C
	15,5 t	18,0 t	
S	15,5 t	17,5 t	



# Litra IKG

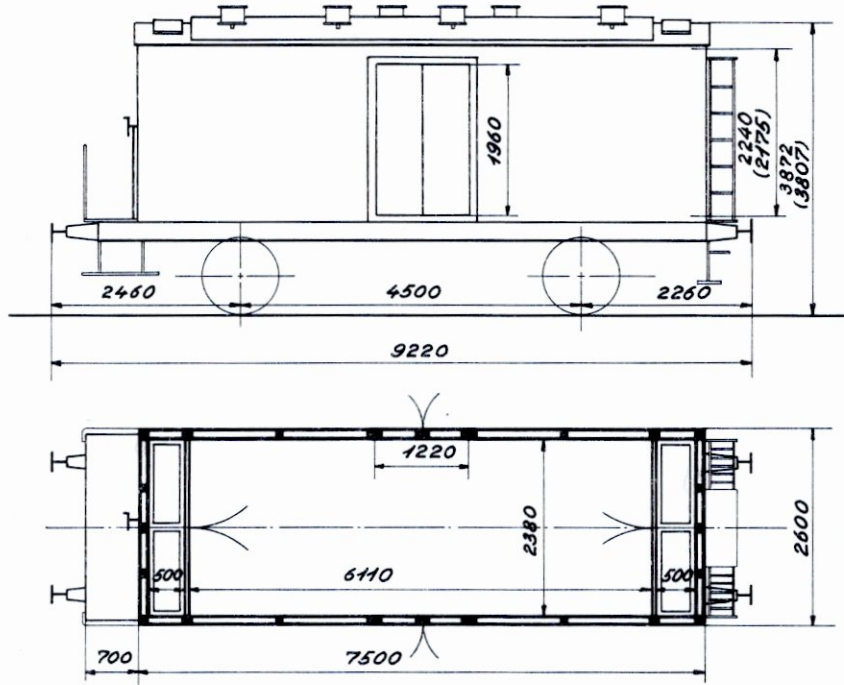

Bundflade 14,5 m<sup>2</sup>

A	B	C
11,0 t	11,0 t	

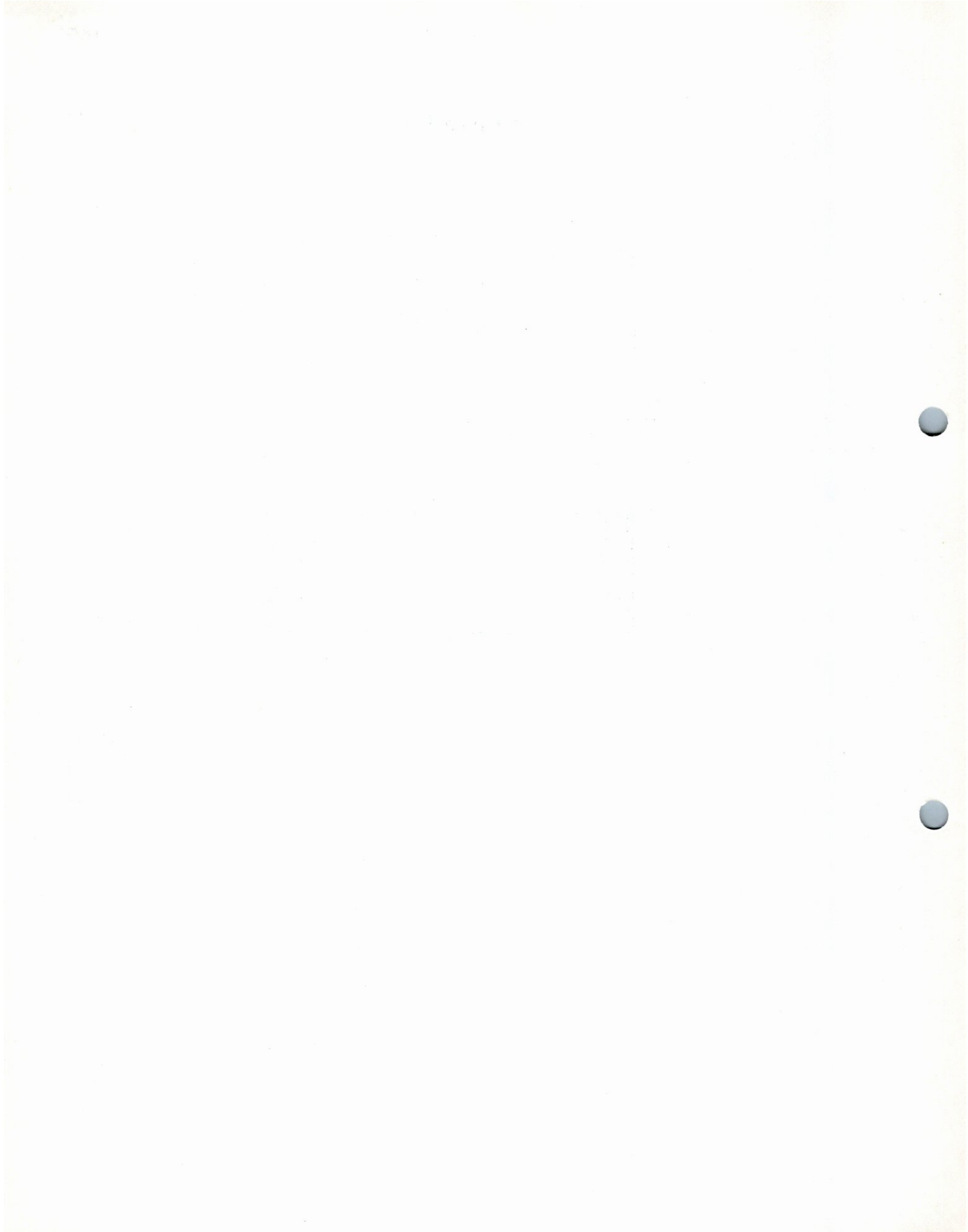

# Litra IKH

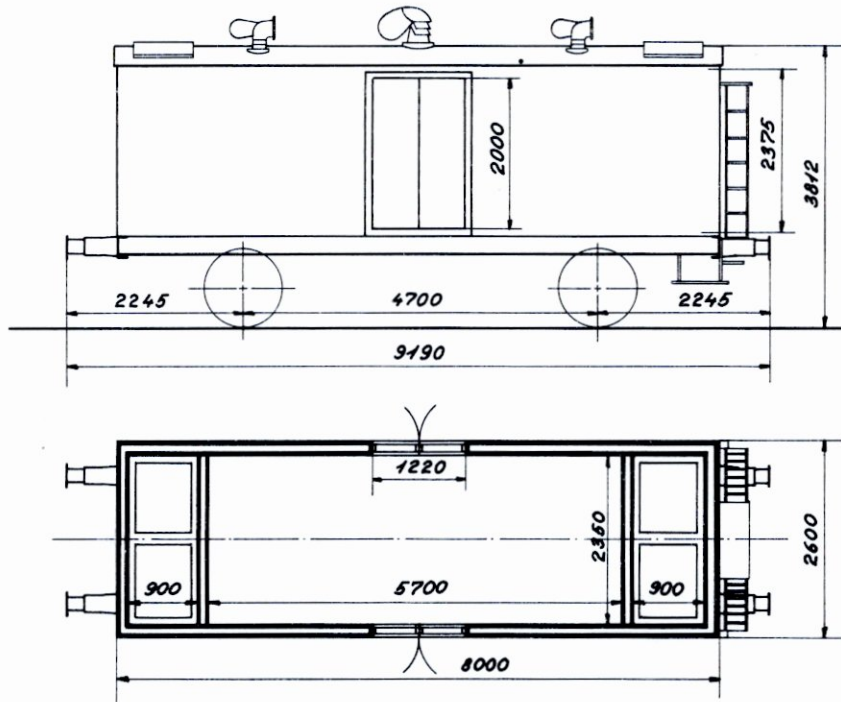

Bundflade 13,4 m<sup>2</sup>

A	B	C
11,0 t		11,0 t



**Litra IKN**  
RIV  
INTERFRIGO

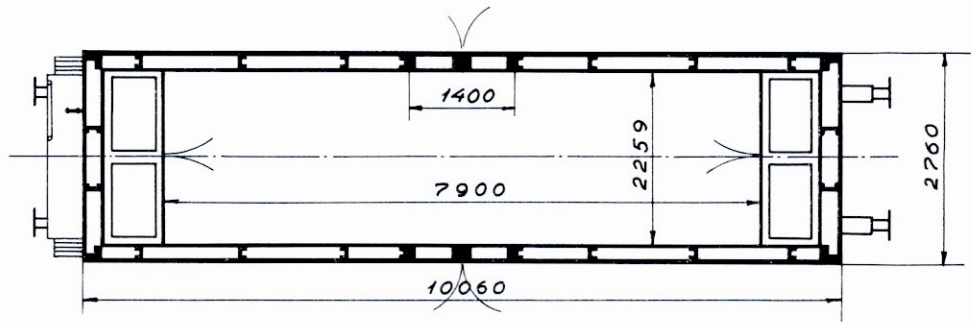
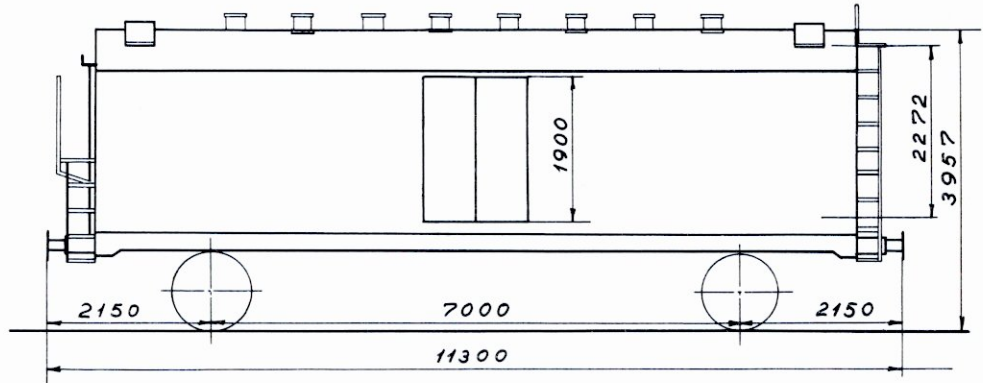

Bundflade 17,8 m<sup>2</sup>

	A	B	C
	13,0 t	17,0 t	19,0 t
<b>S</b>	13,0 t	17,0 t	



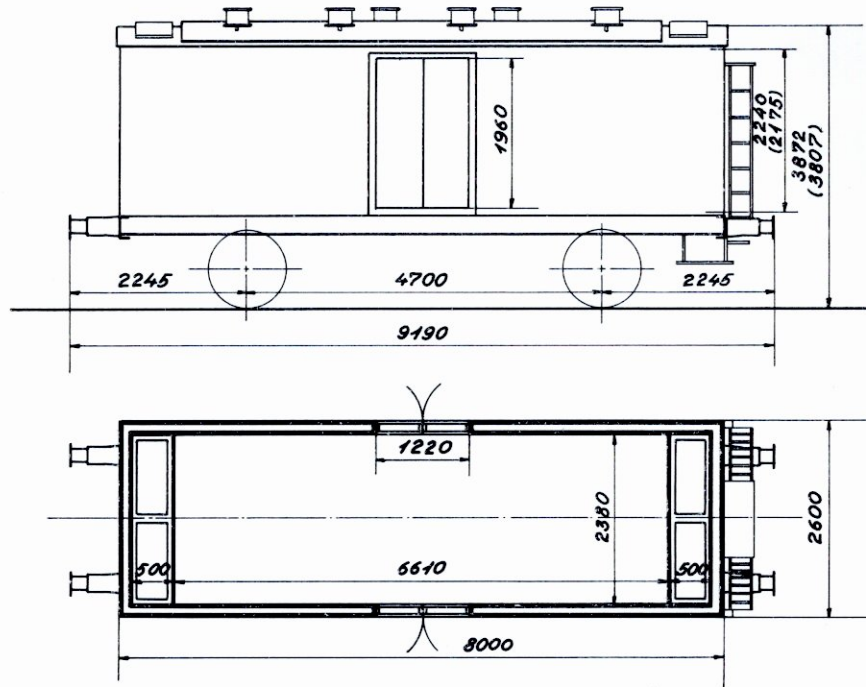

## Litra IKP

Bundflade 15,8 m<sup>2</sup>

A	B	C
11,0 t		11,0 t

1875

1876

1877

1878

1879

1880

1881

1882

1883

1884

1885

1886

1887

1888

1889

1890

1891

1892

1893

1894

1895

1896

1897

1898

1899

1900

1901

1902

1903

1904

1905

1906

1907

1908

1909

1910

1911

1912

1913

1914

1915

1916

1917

1918

1919

1920

1921

1922

1923

1924

1925

1926

1927

1928

1929

1930

1931

1932

1933

1934

1935

1936

1937

1938

1939

1940

1941

1942

1943

1944

1945

1946

1947

1948

1949

1950

# Litra Iks

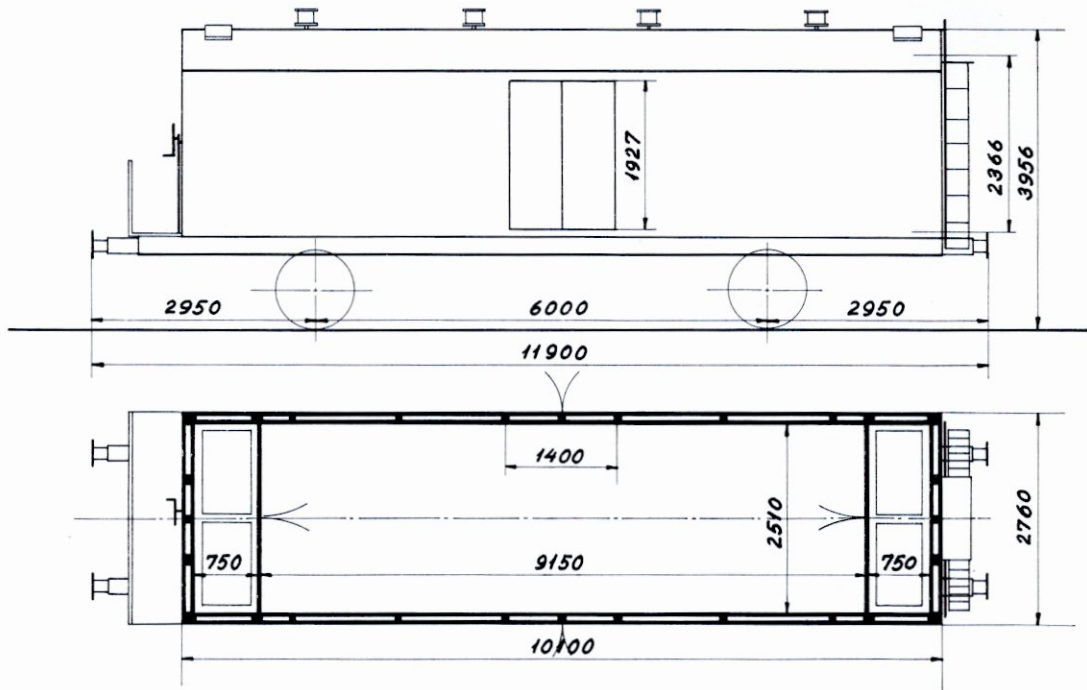

Bundflade 22,9 m<sup>2</sup>

	A	B	C
	14,5 t	16,0 t	
S	10,0 t		

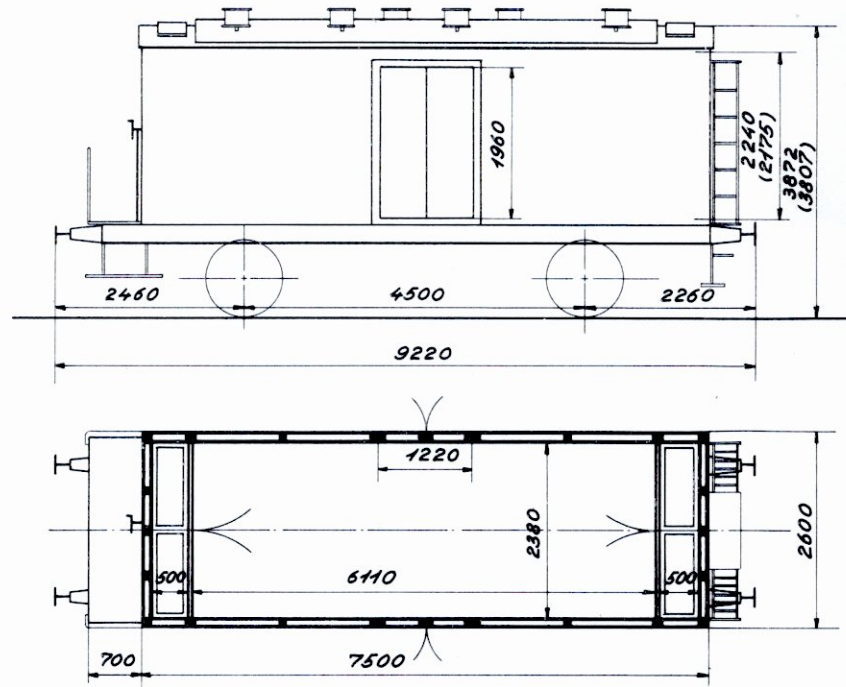

## Litra IKT

Bundflade 14,5 m<sup>2</sup>

A	B	C
11,0 t		11,0 t

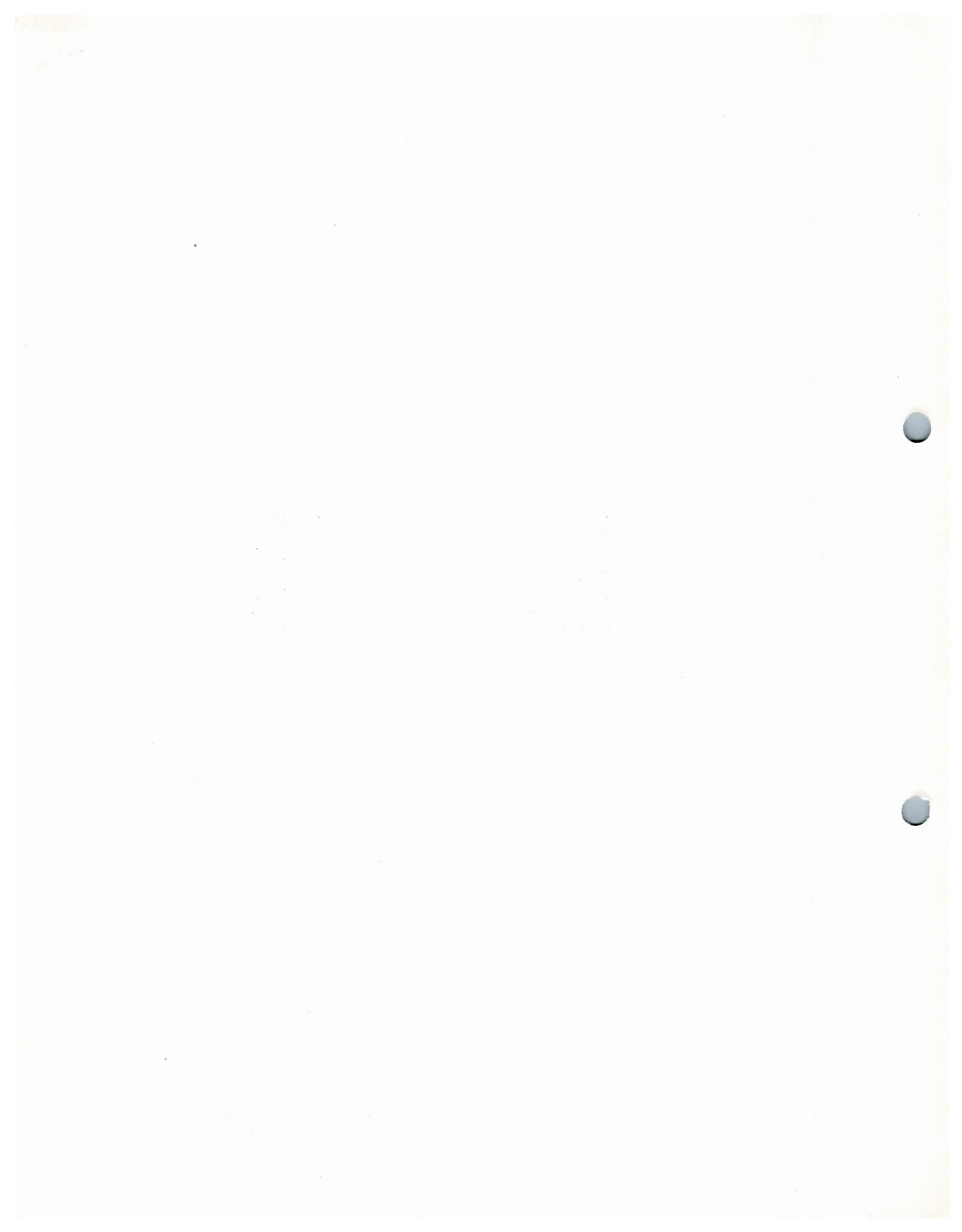

## Litra QG

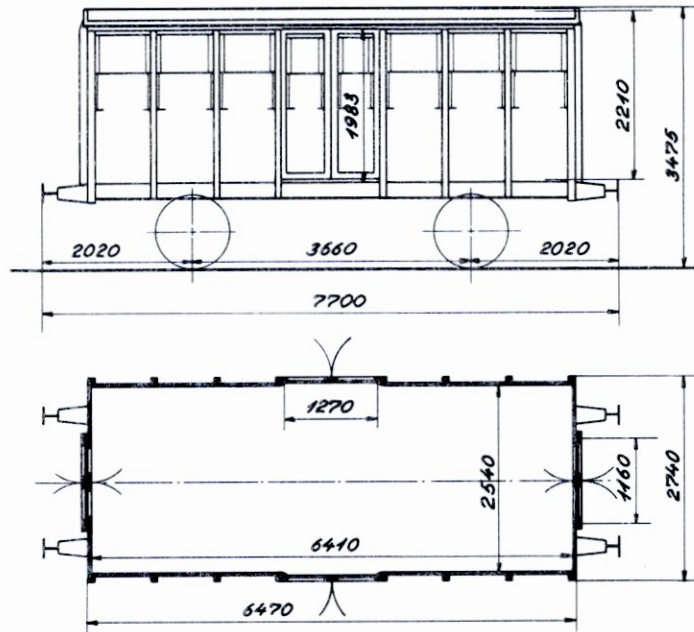
Bundflade 16,3 m<sup>2</sup>

A	B	C
15,5 t		15,5 t



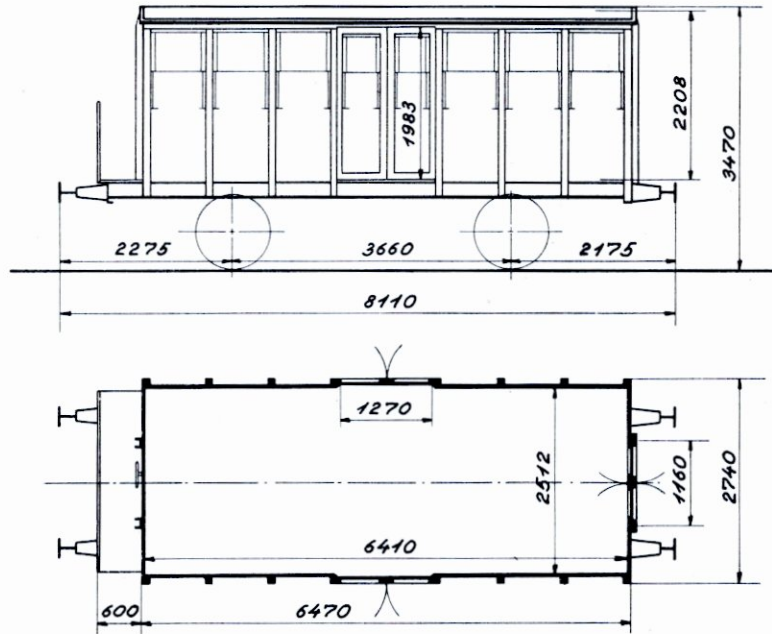

## Litra QGR

Bundflade 16,3 m<sup>2</sup>

A	B	C
15,5 t		15,5 t



# Litra QHL

RIV

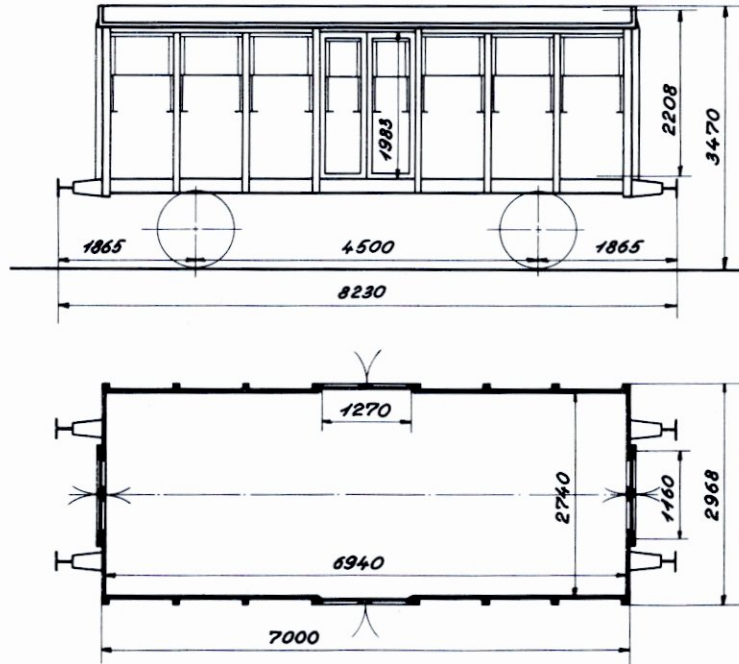

Bundflade 19,0 m<sup>2</sup>

A	B	C
15,5 t		15,5 t

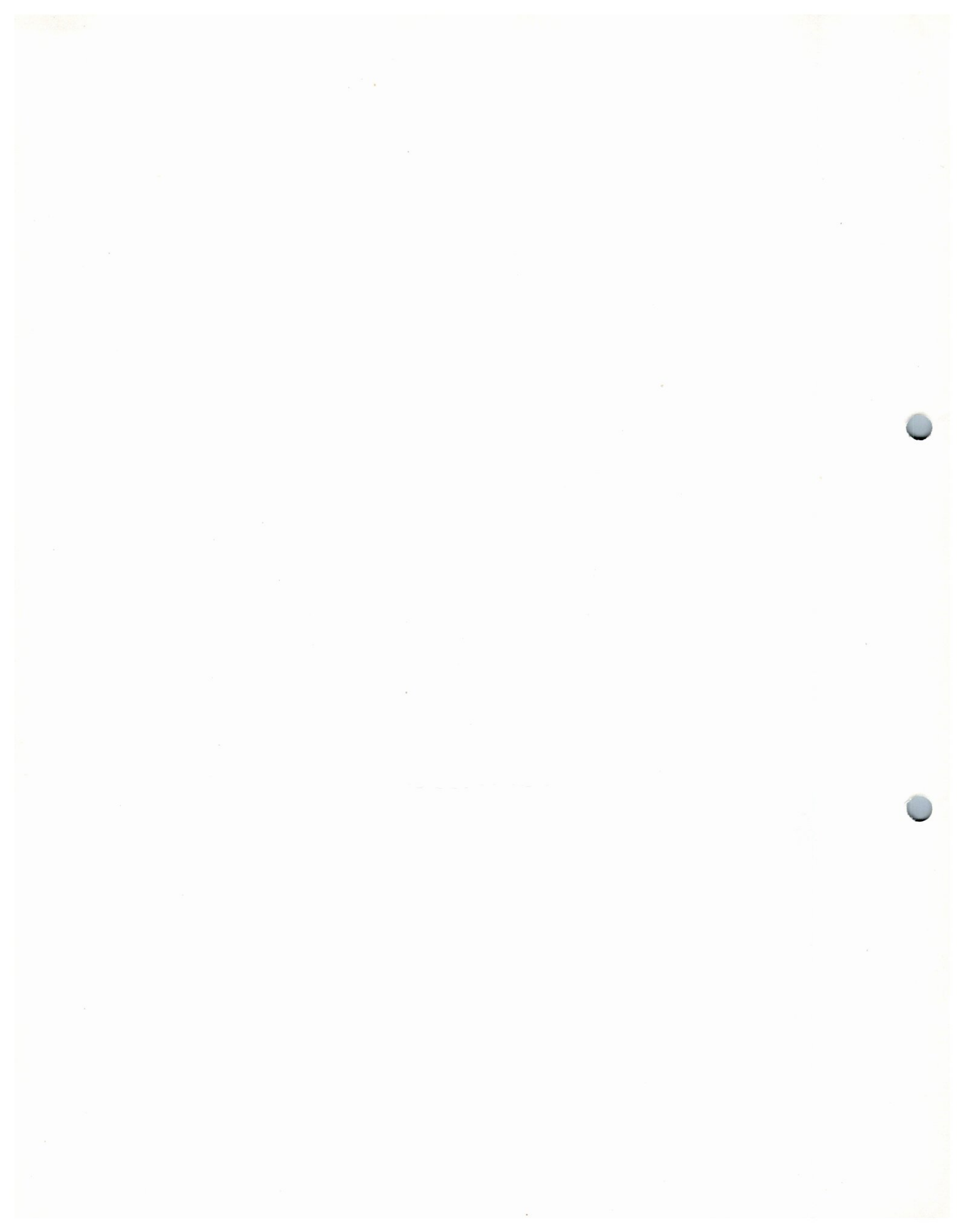

Litra QR

Litra QRL

RIV

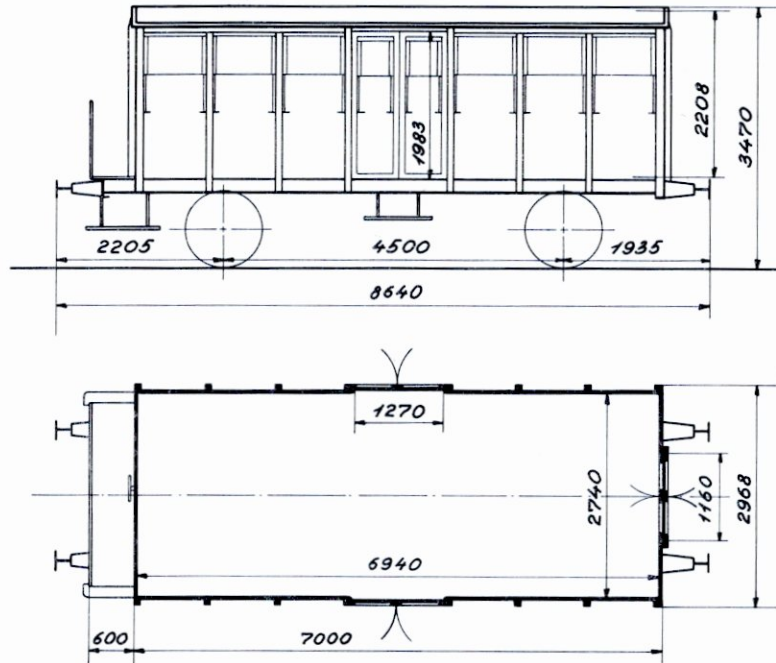

Bundflade 19,0 m<sup>2</sup>

A	B	C
15,5 t	15,5 t	



## . Tdgs 574 0 000-574 0 019

RIV

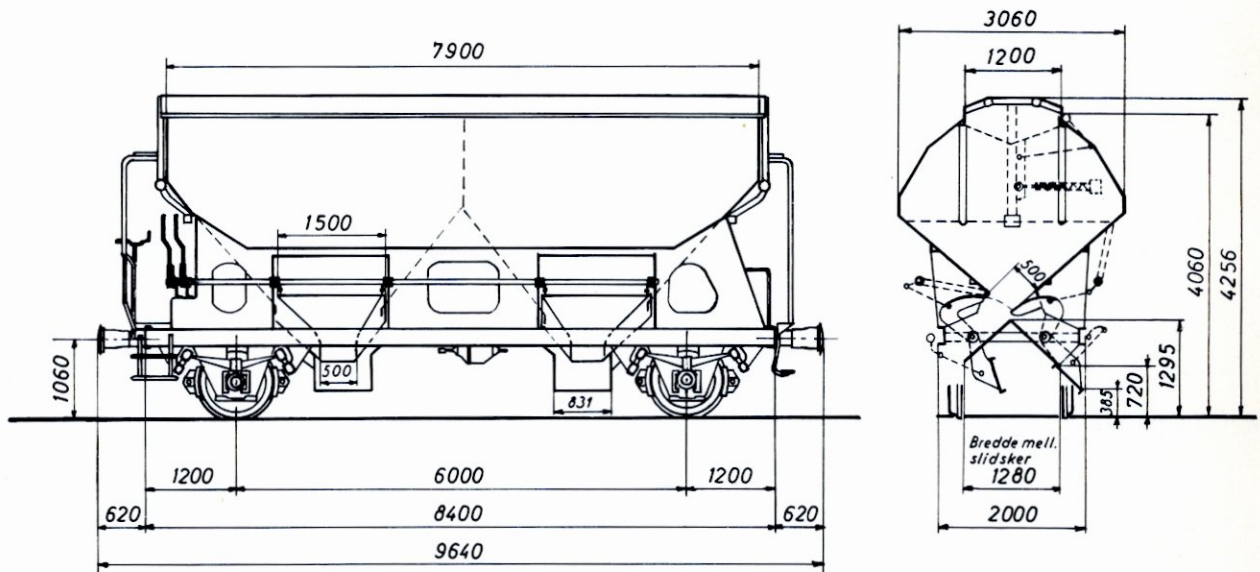

1966 Talbot

Rumindhold 38,0 m<sup>3</sup>

	A	B	C
	19,5 t	23,5 t	27,5 t
S	19,5 t	23,5 t	





## . Tdgs 574 0 000-574 0 019

RIV

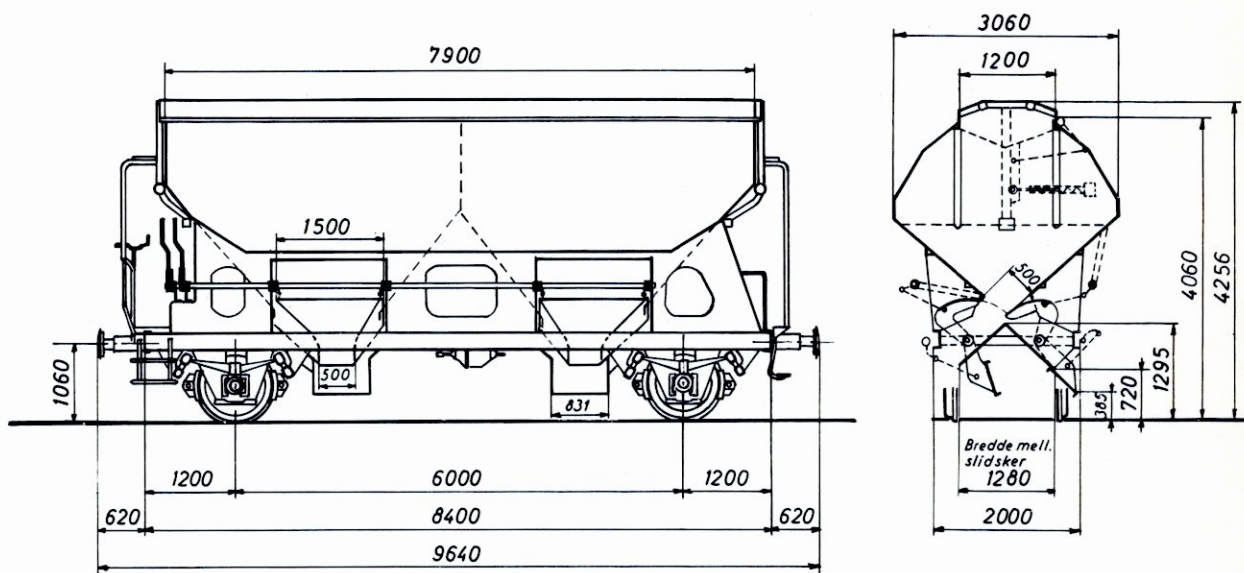

1966 Talbot

Rumindhold 38,0 m<sup>3</sup>

	A	B	C
	19,5 t	23,5 t	27,5 t
S	19,5 t	23,5 t	



. Tdgs 574 0 020 - 574 0 049  
RIV

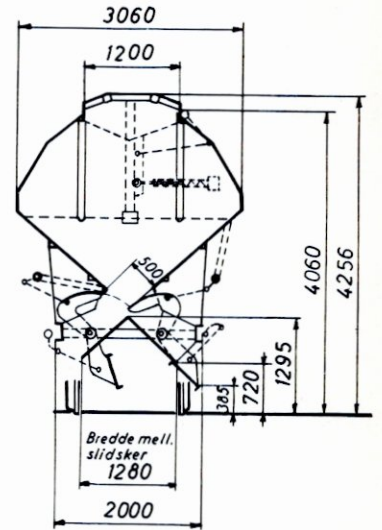
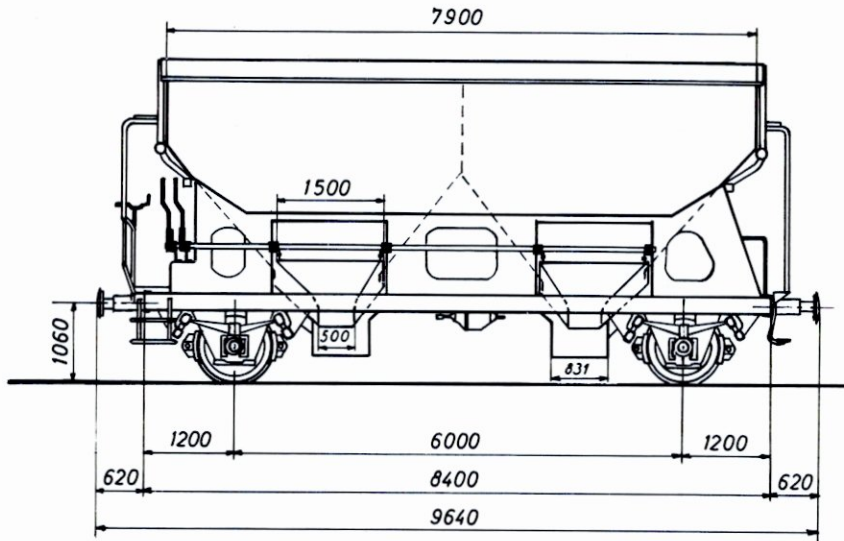

1968 Talbot

Rumindhold 38,0 m<sup>3</sup>

	A	B	C
	19,0t	23,0t	27,0t
S	19,0t	23,0t	



• Uahk 721 1 000-721 1 002

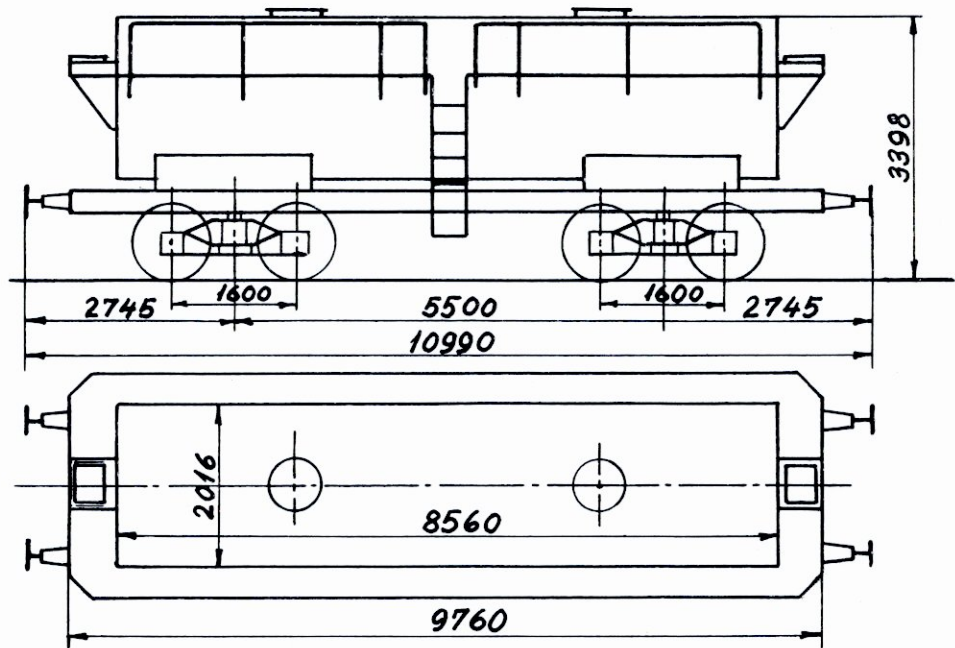

1926 Scandia

Rumindhold 26,6 m<sup>3</sup>

A	B	C
26,0 t		

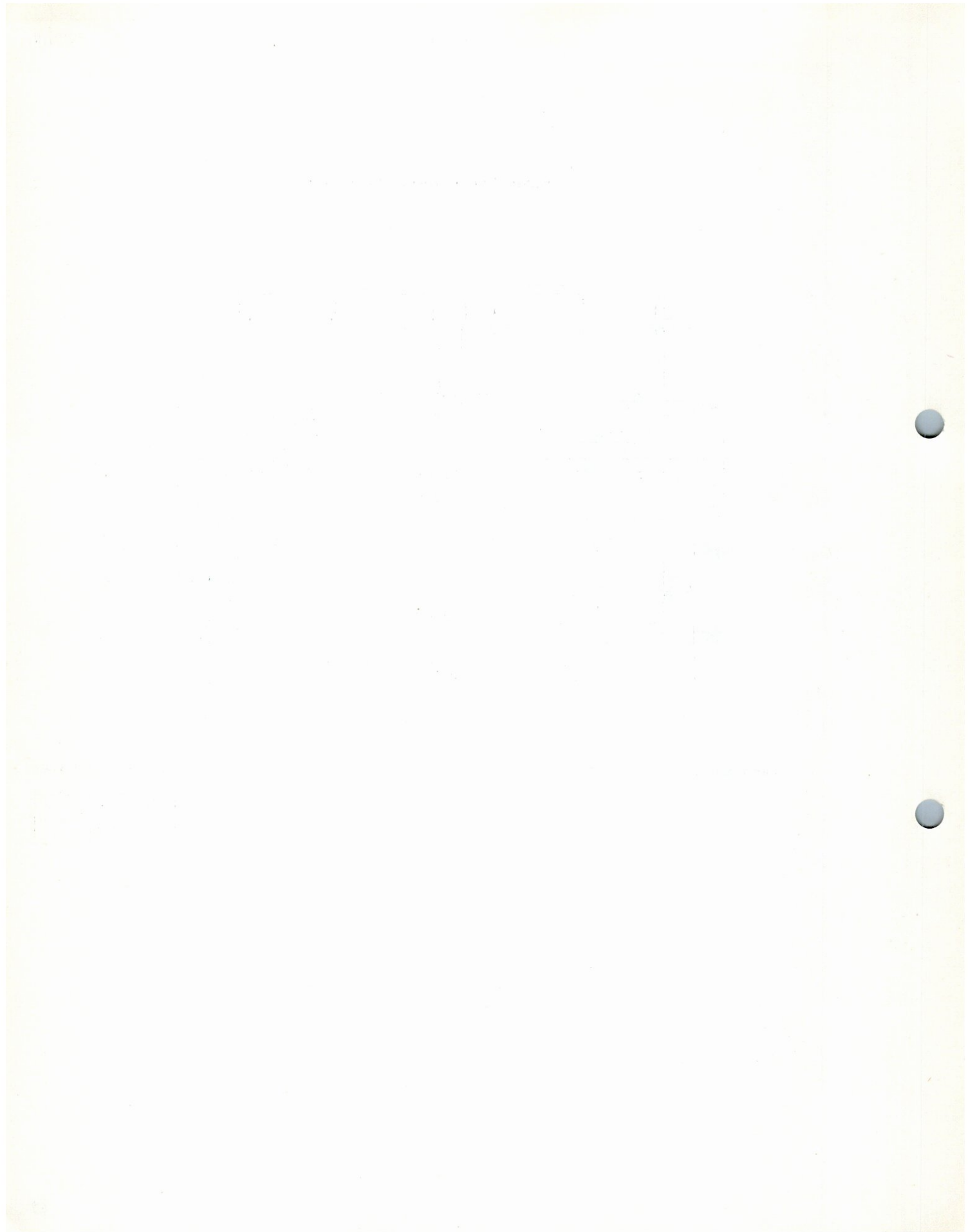

• Ud 901 0 600-901 0 683

RIV

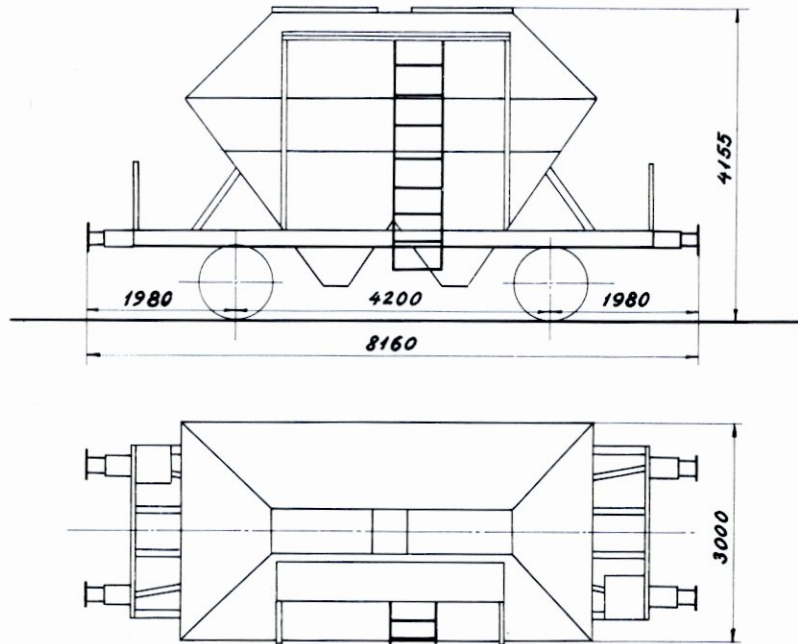

Scandia 1920/24  
Beholder 1958/62

Kun til transport af råsukker

Rumindhold 26,5 m<sup>3</sup>

A	B	C
21,0 t		

Very faint, illegible text at the top of the page, possibly a header or title.





• Uhk 701 3 000-701 3 002

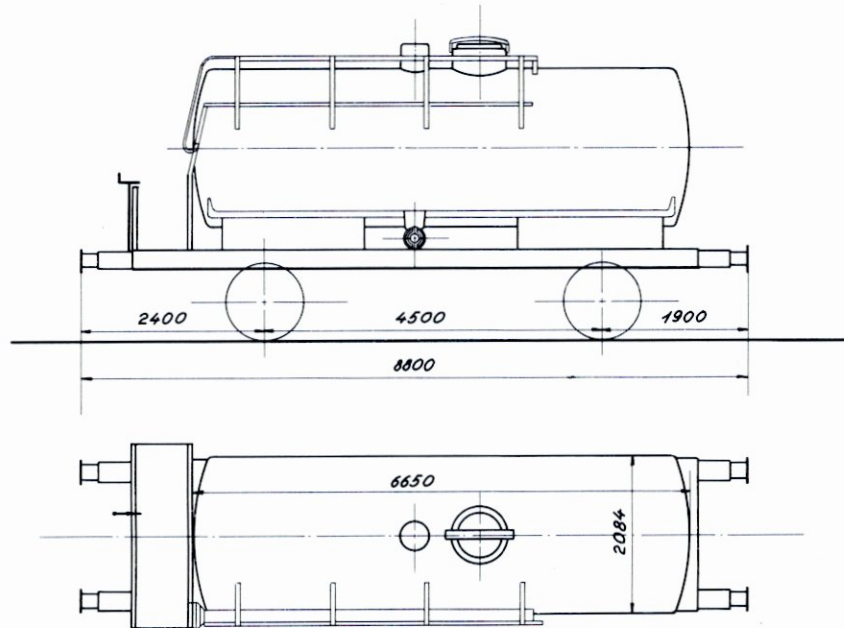

1942 Scandia

Rumindhold 22,0 m<sup>3</sup>

A	B	C
18,5 t		

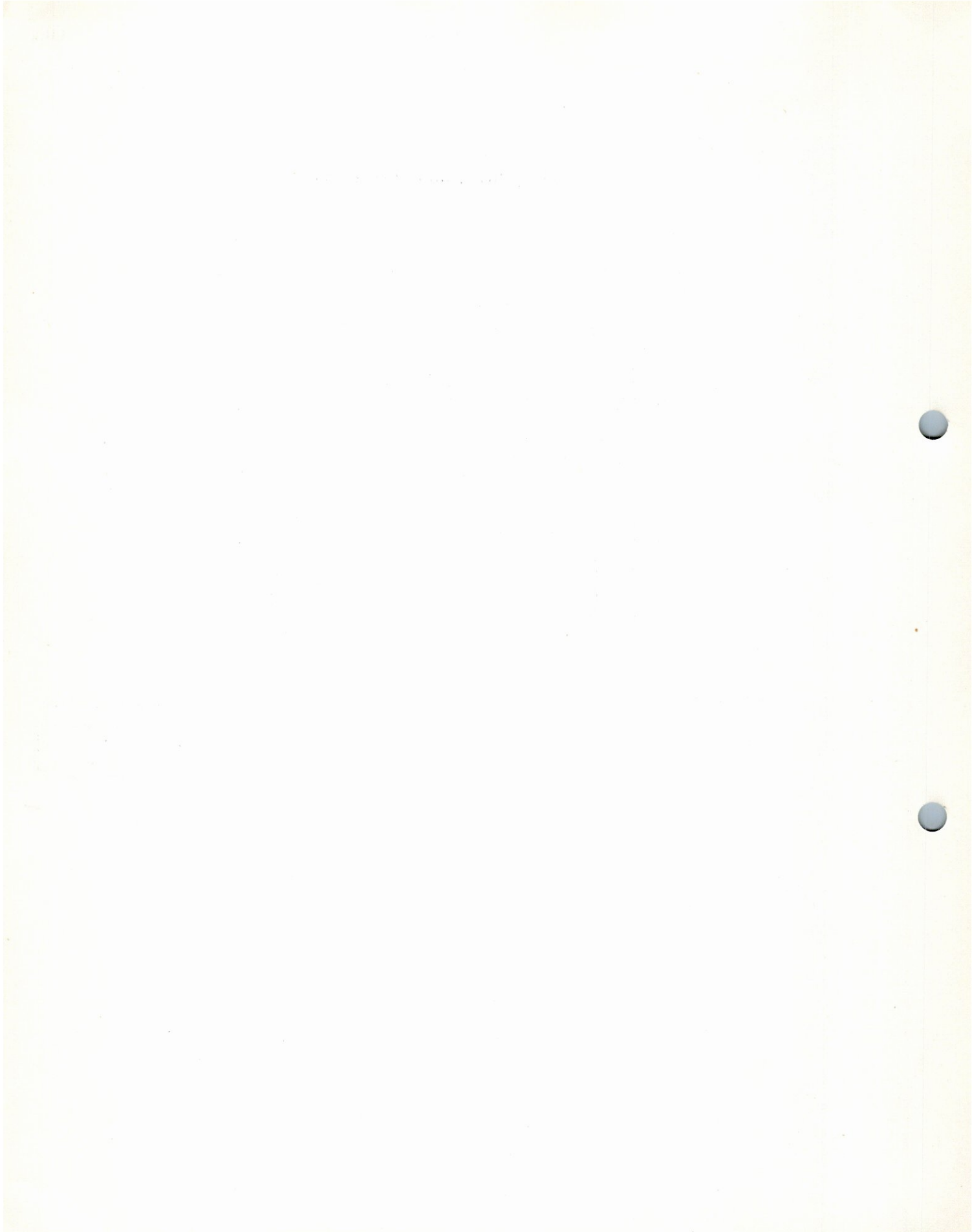

945 0 600-945 0 601

Tjenestegodsvogn

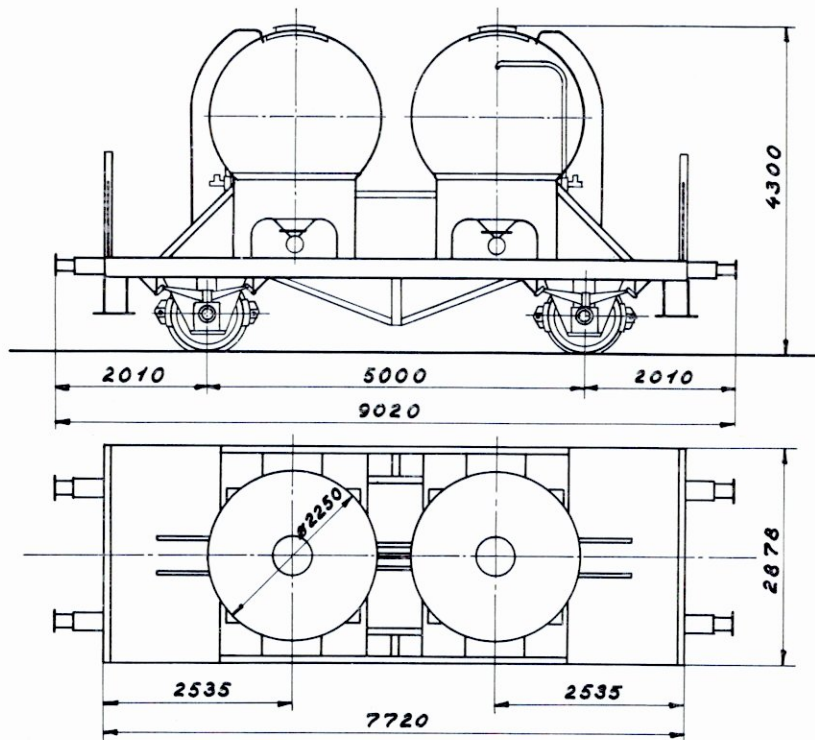

Scandia 1947  
Beholder 1967

Transportvogn for bremsegrus

Rumindhold 2x5,5 m<sup>3</sup>

A	B	C
19,5 t		



**Litra E**

RIV

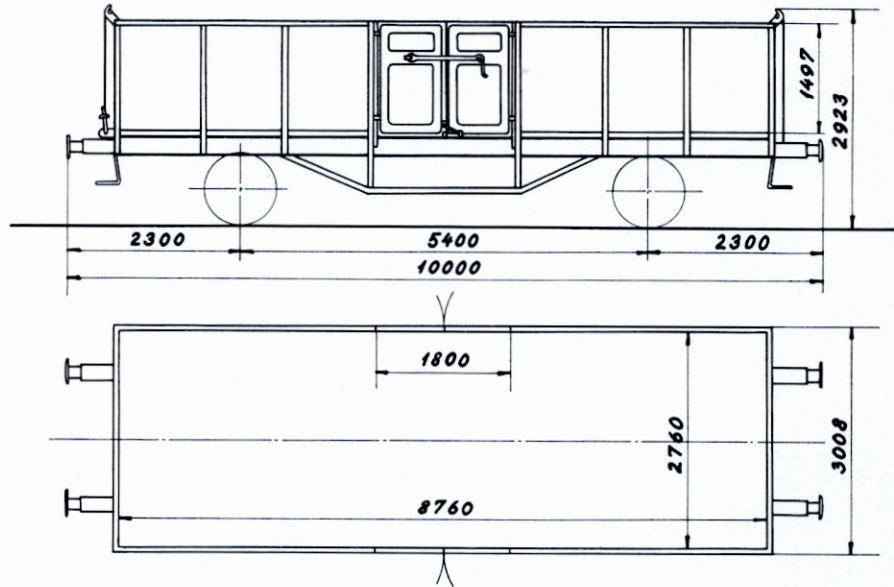

EUROP-mærket

Bundflade 24,0 m<sup>2</sup>

A	B	C
22,0 t	26,0 t	30,0 t

1901



1901



**Litra E**

RIV

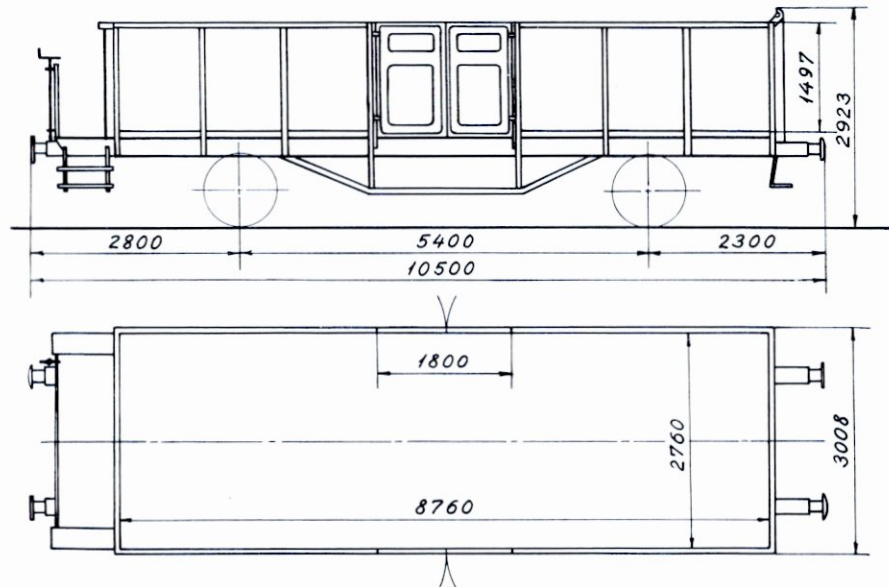
Bundflade 24,0 m<sup>2</sup>

EUROP-mærket

A	B	C
21,0 t	25,0 t	29,0 t

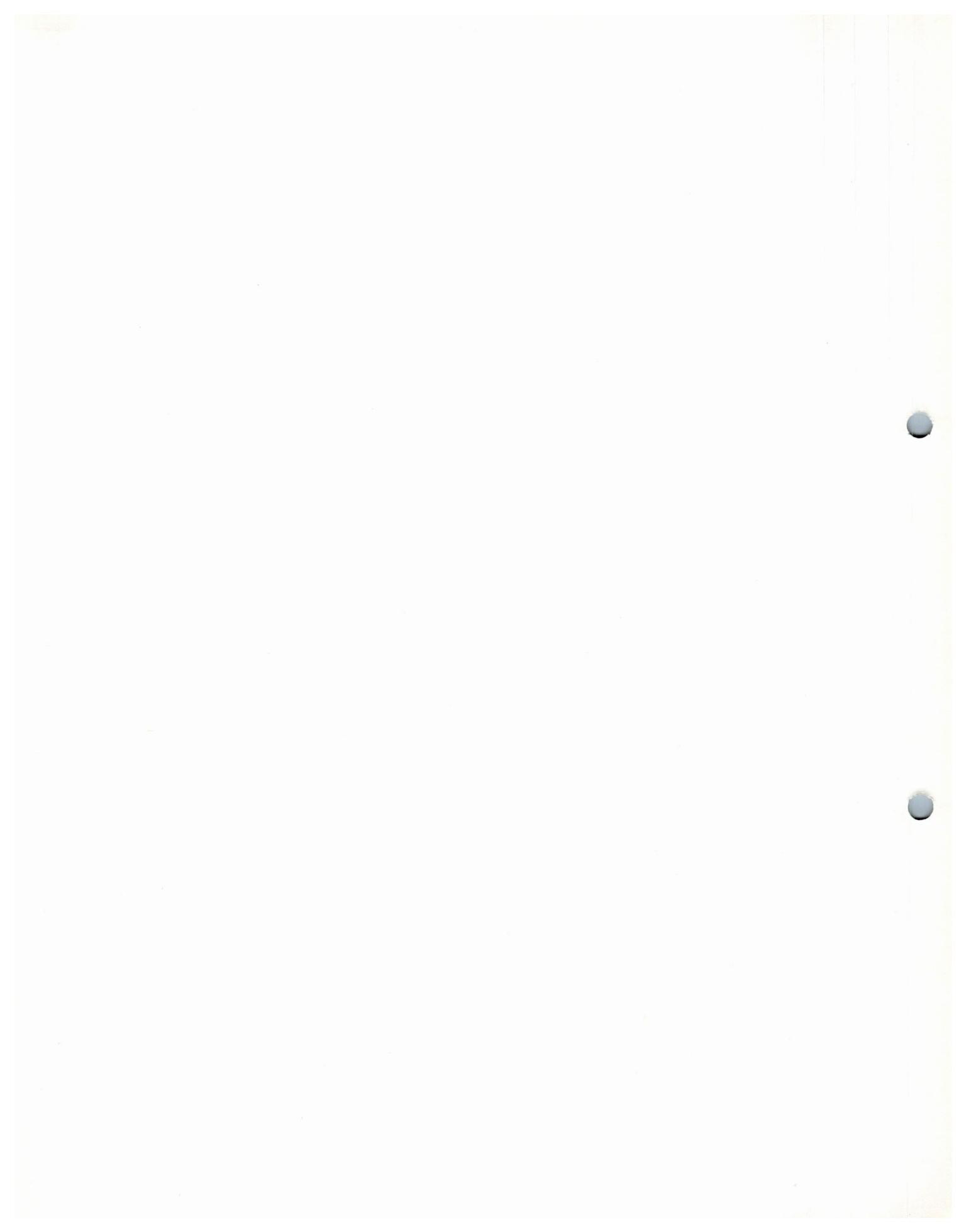



## . Elo 511 0 000 - 511 1 654

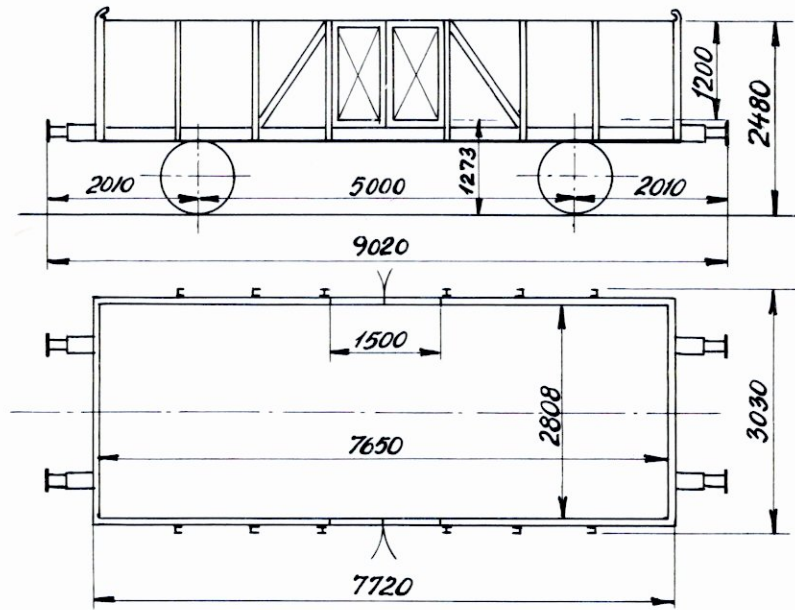

1942/50 Scandia

Bundflade 21,5 m<sup>2</sup>

A	B	C
21,0 t		

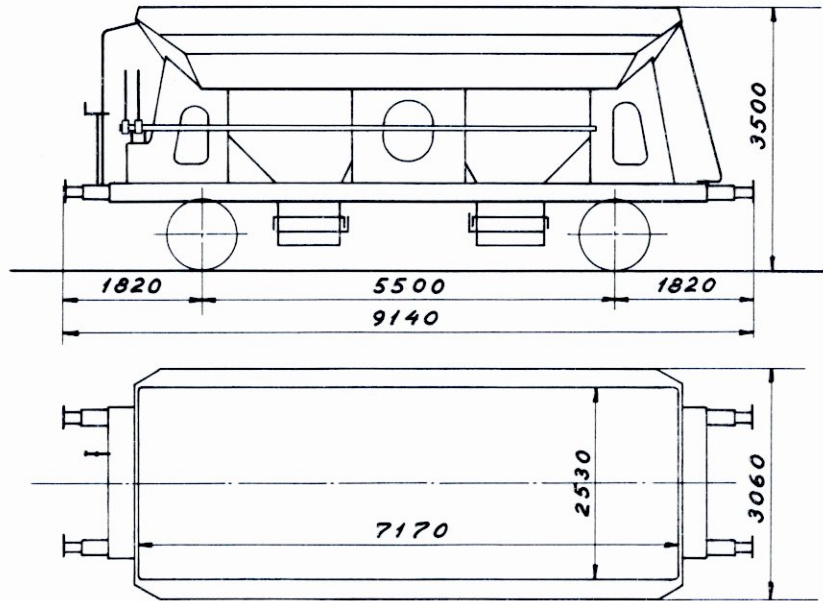

Litra F<sub>d</sub>

A	B	C
20,0 t	24,0 t	28,0 t

1954

1954



11 **Litra PA** nr. 26083, 26095, 26106, 26109, 26117, 26118, 26120, 26122, 26123, 26128, 26129.

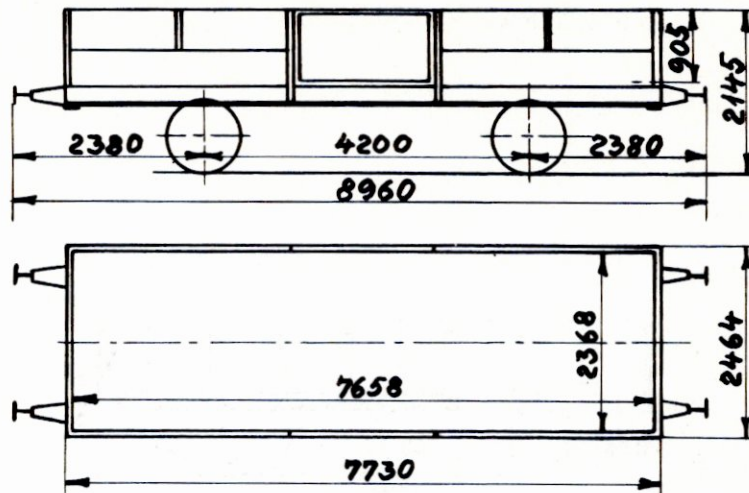

26083. 1910 Scandia  
26095—26109. 1911 «  
26117—26129. 1919 «

Aftagelige endevægge  
Nedklappelige døre

Last 12500 kg  
Bundfl. 18,0 m<sup>2</sup>  
Tara ca. 6600 kg  
Trykluftledning  
Håndbremse

Følgende vogne anvendes til lokale transporter: nr. 26083, 26106, 26128.

1655 **Litra PB** nr. 10001—11655.

R. I. V.

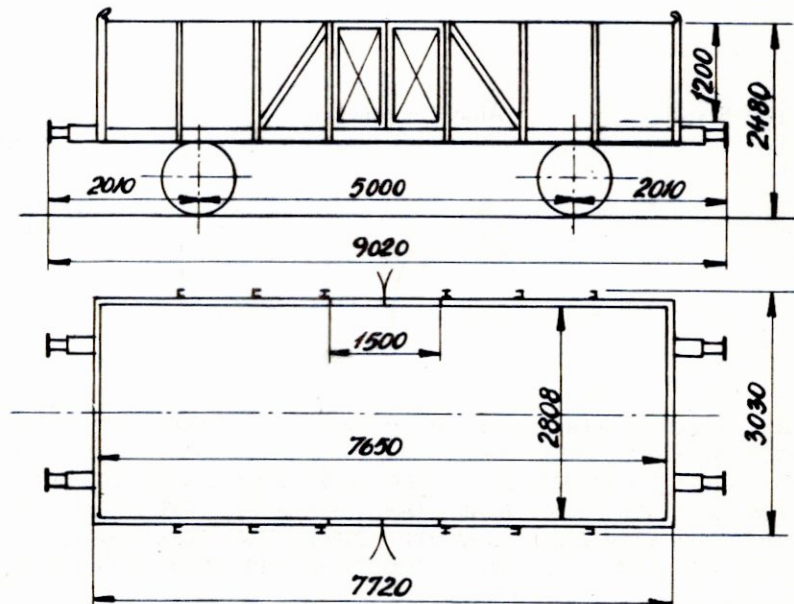

10001—10125. 1942 Scandia  
10126—10705. 1943 «  
10706—10880. 1946 «  
10881—11205. 1947 «  
11206—11405. 1948 «  
11406—11655. 1950 «

Cylinderpuffere eller  
Ringfjederpuffere  
Aftagelige endelemme

Last 20000 kg  
Bundfl. 21,5 m<sup>2</sup>  
Tara ca. 9400 kg  
Trykluftbremse  
Håndbremse

11 **Litra Pc** nr. 26658, 26663, 26664, 26666, 26667, 26668, 26669, 26670, 26672, 26673, 26674.

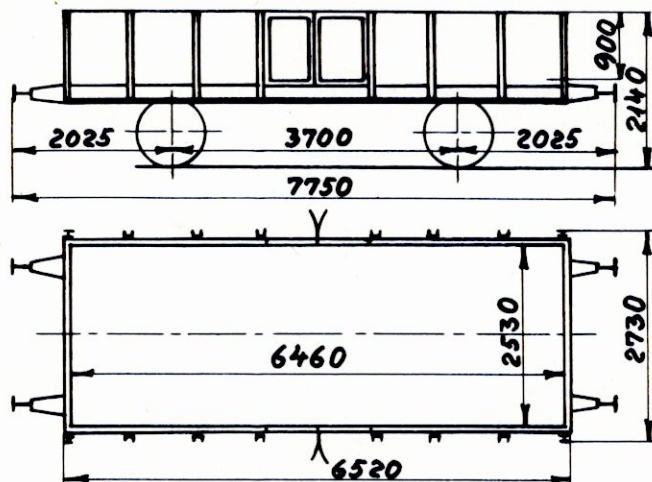

26658—26667. 1905 Scandia  
26668—26674. 1911 «

Aftagelige endevægge

Last 12500 kg  
Bundfl. 16,3 m<sup>2</sup>  
Tara ca. 5900 kg  
Trykluftledning  
Håndbremse

Følgende Pc vogne anvendes til lokale transporter: nr. 26658, 26674, 26702, 26714, 26725, 26730, 26746, 26748, 26750, 26752, 26760, 26762, 26768, 26770, 26783, 26786, 26789, 26793, 26802, 26803, 26805, 26807, 26810, 26829, 26857, 26862, 26864, 26869, 26885, 26887, 26892, 26894, 26900, 26901, 26905, 26915, 26918, 26919, 26922, 26926, 26930, 26936, 26943, 26946, 26948, 26949, 26952, 26963, 26965, 26980, 26982, 26989, 26990, 26995, 26997, 27019, 27029, 27041, 27042, 27047, 27054, 27058, 27059, 27074, 27084, 27087, 27093, 27105, 27108, 27117, 27129, 27147, 27156, 27174, 27185, 27186, 27192, 27201, 27208, 27221, 27223, 27225.

242 **Litra Pc nr.** 26675, 26677, 26679, 26682, 26688, 26689, 26701, 26702, 26709, 26714, 26722, 26725, 26727, 26730, 26744, 26746, 26748, 26750, 26752, 26760, 26762, 26767, 26768, 26770, 26774, 26778, 26779, 26783, 26786, 26789, 26793, 26800, 26801, 26802, 26803, 26805, 26807, 26810, 26813, 26815, 26817, 26819, 26821, 26825, 26826, 26829, 26831, 26842, 26845, 26857, 26862, 26864, 26865, 26869, 26873, 26874, 26875, 26876, 26877, 26878, 26879, 26880, 26881, 26882, 26884, 26885, 26887, 26890, 26892, 26893, 26894, 26896, 26897, 26900, 26901, 26903, 26905, 26907, 26910, 26914, 26915, 26917, 26918, 26919, 26921, 26922, 26923, 26926, 26927, 26929, 26930, 26931, 26936, 26938, 26941, 26943, 26946, 26947, 26948, 26949, 26952, 26957, 26962, 26963, 26964, 26965, 26966, 26968, 26969, 26970, 26971, 26976, 26977, 26978, 26980, 26981, 26982, 26983, 26988, 26989, 26990, 26991, 26994, 26995, 26997, 27000, 27001, 27002, 27006, 27007, 27009, 27014, 27019, 27020, 27024, 27025, 27026, 27028, 27029, 27030, 27032, 27033, 27034, 27036, 27037, 27038, 27041, 27042, 27043, 27044, 27047, 27051, 27054, 27055, 27056, 27058, 27059, 27061, 27062, 27065, 27066, 27068, 27070, 27073, 27074, 27075, 27077, 27078, 27079, 27080, 27083, 27084, 27087, 27089, 27093, 27095, 27096, 27101, 27105, 27106, 27107, 27108, 27109, 27110, 27113, 27114, 27115, 27116, 27117, 27119, 27124, 27125, 27127, 27129, 27134, 27137, 27143, 27146, 27147, 27148, 27149, 27150, 27152, 27154, 27156, 27157, 27162, 27163, 27164, 27165, 27169, 27170, 27172, 27174, 27178, 27180, 27185, 27186, 27187, 27189, 27191, 27192, 27196, 27197, 27198, 27199, 27201, 27203, 27204, 27207, 27208, 27214, 27216, 27217, 27218, 27219, 27220, 27221, 27222, 27223, 27225, 27226.

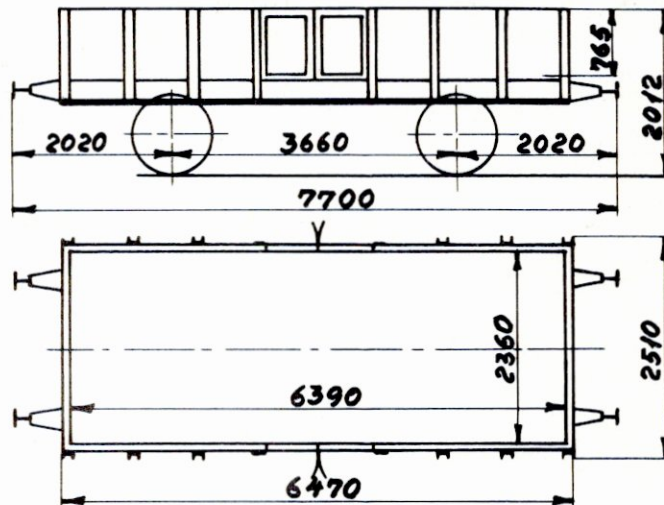

26675. 1908 Scandia  
 26677—26689. 1890 «  
 26701—26714. 1875 Wagenbau  
 26722—26819. 1876-1877 Breslau  
 26821—26825. 1877 Wagenbau  
 26826—26845. 1878 Breslau  
 26857. 1877 Scandia  
 26862—26957. 1882 Zypen  
 26962—27044. 1883 Breslau  
 27047—27110. 1884 «  
 27113—27137. 1886 Scandia  
 27143—27216. 1890 «  
 27217—27220. 1912 «  
 27221—27223. 1907 «  
 27225—27226. 1908 «

Aftagelige endevægge

Last 12500 kg  
 Bundfl. 15,1 m<sup>2</sup>  
 Tara ca. 5600 kg  
 Trykluftledning  
 Håndbremse

3 **Litra PD** nr. 27401—27403

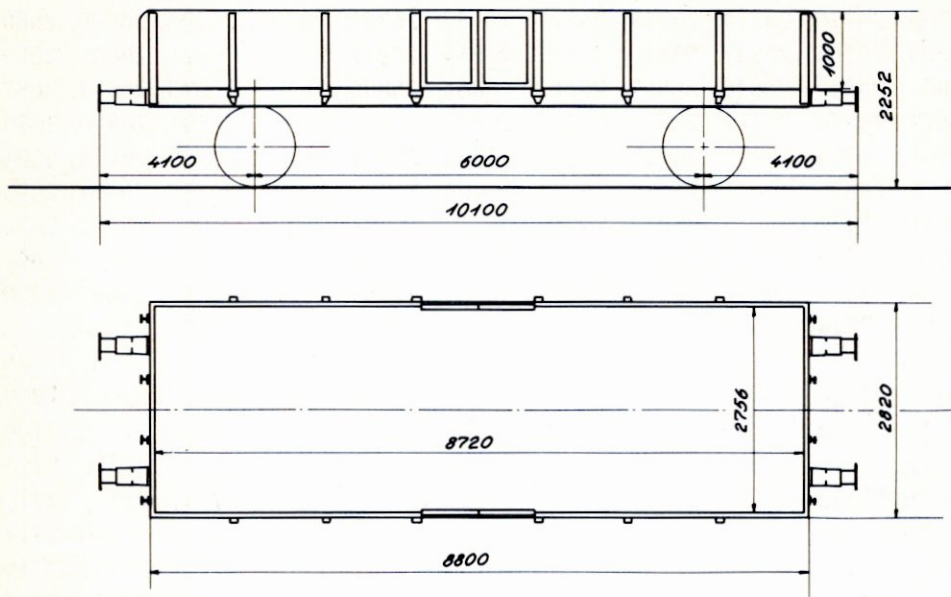

27401. 1944 Scandia  
27402—27403. 1942 «

Aftagelige side- og endelemme

Last 22000 kg  
Bundfl. 24,0 m<sup>2</sup>  
Tara ca. 10400 kg  
Trykluftbremse  
Håndbremse



## 47 Litra PE nr. 17701—17747

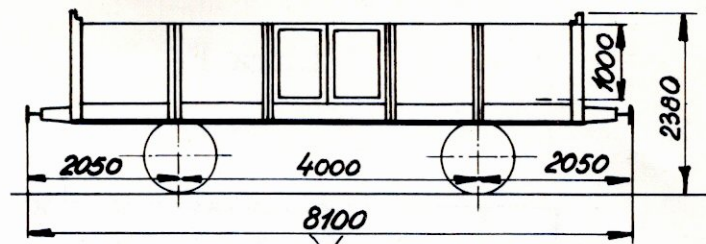

17701. 1920 Aachen  
 17702. « Bremen  
 17703. 1919 «  
 17704. 1920 Aachen  
 17705. 1919 Bremen  
 17706. « Braunschweig  
 17707. 1920 Aachen  
 17708. 1919 Bremen  
 17709. 1920 Aachen  
 17710. 1919 Braunschweig  
 17711. « Bremen  
 17712. 1920 Aachen  
 17713—17722. 1919 Bremen  
 17723—17730. 1920 Breslau  
 17731—17732. 1919 Niesky  
 17733. 1920 Aachen  
 17734—17738. 1919 Bremen  
 17739—17747. « Zwickau

Aftagelige endevægge

Last 15000 kg  
 Bundfl. 18,3 m<sup>2</sup>  
 Tara ca. 7800 kg  
 Trykluftledning  
 Håndbremse

## 19 Litra PER nr. 17682—17700

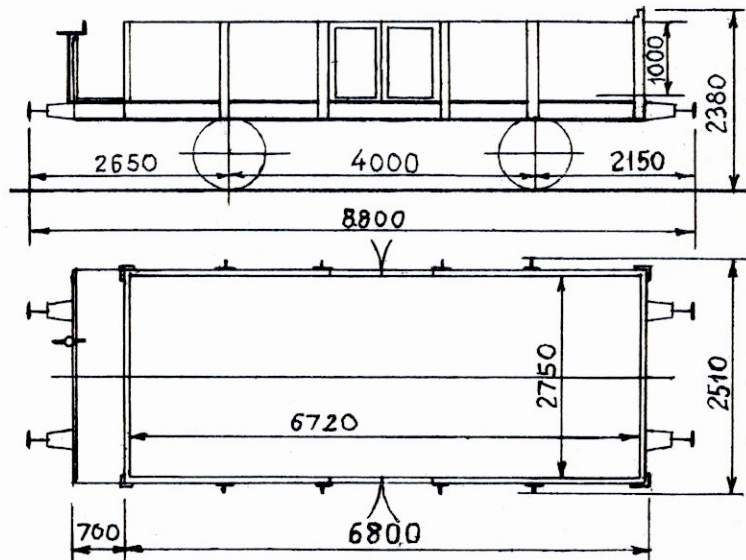

Aftagelig endevæg

- 17682—17684. 1919 Zwickau  
 17685—17688. 1920 Breslau  
 17689—17690. 1919 Bremen  
 17691—17700. « M. A. N

Last 15000 kg  
 Bundfl. 18,3 m<sup>2</sup>  
 Tara ca. 8300 kg  
 Trykluftledning  
 Rangierskruebremse

## Litra PF

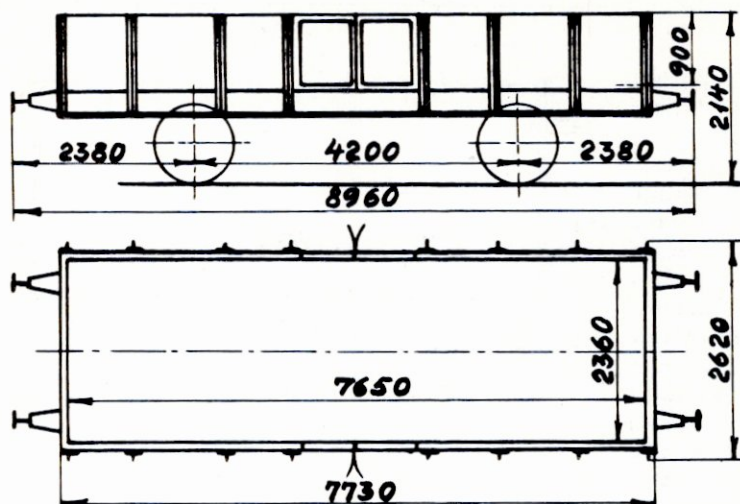

15081—15240.	1898	Zypen
15243—15248.	1899	Maribo
15251—15340.	1900	«
15341—15357.	«	Scandia
15359—15461.	1901	«
15462—15543.	1902	«
15544—15643.	1905	«
15644—15718.	1906	Zypen
15719—15743.	1907	Scandia
15744—15783.	1894	Zypen
15786—15860.	1895	Scandia
15861—15884.	1896	Zypen
15885—16096.	1909	Scandia
16097—16219.	1910	«
17501—17502.	1916	«
17503—17506.	1918	«
17507—17508.	1920	«
17509.	1916	«
17510.	1915	«
17511.	1917	«
17512—17515.	1916	«
17516—17525.	1919	«
17526—17527.	1917	«
17528—17535.	1907	Arløf
17536—17542.	1916	Scandia
17543—17552.	1917	«
17553.	1916	«

Aftagelige endevægge

Last 15000 kg  
 Bundfl. 18,0 m<sup>2</sup>  
 Tara ca. 6700 kg  
 Trykluftledning  
 Håndbremse

Følgende vogne anvendes til lokale transporter: nr. 15741, 15756, 15935.

**397 Litra PFB** 16220, 16221, 16222, 16223, 16224, 16225, 16226, 16227, 16228, 16229, 16230, 16231, 16232, 16233, 16234, 16235, 16236, 16237, 16238, 16239, 16240, 16241, 16242, 16243, 16244, 16245, 16246, 16247, 16248, 16249, 16250, 16251, 16252, 16253, 16254, 16255, 16256, 16257, 16258, 16259, 16260, 16261, 16262, 16263, 16264, 16265, 16266, 16267, 16268, 16269, 16270, 16271, 16272, 16273, 16274, 16275, 16276, 16277, 16278, 16279, 16280, 16281, 16283, 16284, 16285, 16286, 16287, 16288, 16289, 16290, 16291, 16292, 16293, 16294, 16295, 16296, 16297, 16298, 16299, 16300, 16301, 16302, 16304, 16305, 16306, 16307, 16309, 16310, 16311, 16312, 16313, 16314, 16315, 16316, 16317, 16318, 16319, 16320, 16321, 16322, 16323, 16324, 16325, 16326, 16327, 16328, 16329, 16330, 16331, 16332, 16333, 16334, 16335, 16336, 16337, 16338, 16339, 16340, 16341, 16342, 16343, 16344, 16345, 16346, 16347, 16348, 16349, 16350, 16351, 16352, 16353, 16354, 16355, 16356, 16357, 16358, 16359, 16360, 16361, 16362, 16363, 16364, 16365, 16366, 16367, 16368, 16369, 16370, 16371, 16372, 16373, 16374, 16375, 16376, 16377, 16378, 16379, 16380, 16381, 16382, 16383, 16384, 16385, 16386, 16387, 16388, 16389, 16390, 16391, 16392, 16393, 16394, 16395, 16396, 16397, 16398, 16399, 16400, 16401, 16402, 16403, 16404, 16405, 16406, 16407, 16408, 16409, 16410, 16411, 16412, 16413, 16414, 16415, 16416, 16417, 16418, 16419, 16420, 16421, 16422, 16423, 16424, 16425, 16426, 16427, 16428, 16429, 16430, 16431, 16432, 16433, 16434, 16435, 16436, 16437, 16438, 16439, 16440, 16441, 16442, 16443, 16444, 16445, 16446, 16447, 16448, 16449, 16450, 16451, 16452, 16453, 16454, 16455, 16456, 16457, 16458, 16459, 16460, 16461, 16462, 16463, 16464, 16465, 16466, 16467, 16468, 16469, 16470, 16471, 16472, 16473, 16474, 16475, 16476, 16477, 16478, 16479, 16480, 16481, 16482, 16483, 16484, 16485, 16486, 16487, 16488, 16489, 16490, 16491, 16492, 16493, 16494, 16495, 16496, 16497, 16498, 16499, 16500, 16501, 16502, 16503, 16504, 16505, 16506, 16507, 16508, 16509, 16510, 16511, 16512, 16513, 16514, 16515, 16516, 16517, 16518, 16519, 16520, 16521, 16522, 16523, 16524, 16525, 16526, 16527, 16528, 16529, 16530, 16531, 16532, 16533, 16534, 16535, 16536, 16537, 16538, 16539, 16540, 16541, 16542, 16543, 16544, 16545, 16546, 16547, 16548, 16549, 16550, 16551, 16552, 16553, 16554, 16555, 16556, 16557, 16558, 16559, 16560, 16561, 16562, 16563, 16564, 16565, 16566, 16567, 16568, 16569, 16570, 16571, 16572, 16573, 16574, 16575, 16576, 16577, 16578, 16579, 16580, 16581, 16582, 16583, 16584, 16585, 16586, 16587, 16588, 16589, 16590, 16591, 16592, 16593, 16594, 16595, 16596, 16597, 16598, 16599, 16600, 16601, 16602, 16603, 16604, 16605, 16606, 16607, 16608, 16609, 16610, 16611, 16612, 16613, 16614, 16615, 16616, 16617, 16618, 16619.

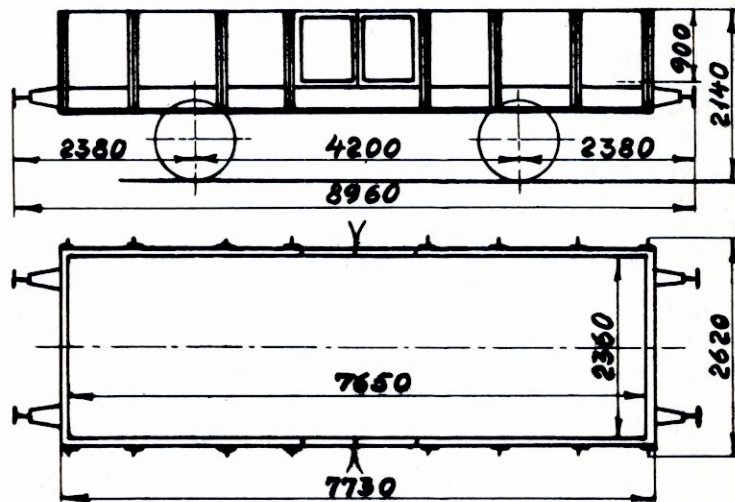

16220—16224. 1910 Scandia  
 16225—16234. 1909 Mjølner  
 16235—16274. 1910 Scandia  
 16275—16324. 1911 «  
 16325—16424. 1912 «  
 16425—16439. « Mjølner  
 16440—16447. 1914 Scandia  
 16448—16530. 1915 «  
 16540—16619. 1916 «

Aftagelige endevægge

Last 15000 kg  
 Bundfl. 18,0 m<sup>2</sup>  
 Tara ca. 7700 kg  
 Trykluftbremse  
 Håndbremse

## Litra PFR

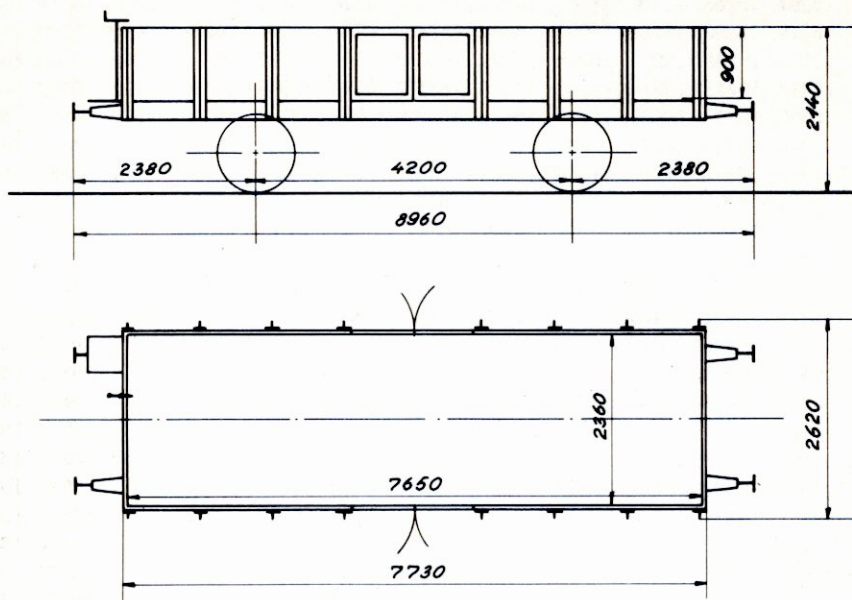

14020—14029. 1910 Scandia  
 14030—14109. 1907 «  
 14110—14229. 1908 «  
 14230—14329. 1896 Zypen  
 14332—14337. 1894 «  
 14339—14386. 1895 Scandia  
 14389—14420. 1897 Herbrand  
 14424—14447. 1907 Scandia  
 14449—14522. 1906 Maribo  
 14523—14547. 1905 Scandia  
 14548—14571. « Maribo  
 14574—14597. « Scandia  
 14599—14696. 1903 «  
 14699—14797. 1902 «  
 14798—14896. 1900 Neustadt  
 14898—14900. « Scandia  
 14901—15000. 1899 Maribo  
 15001—15079. 1898 «  
 17493—17495. 1907 Arløf  
 17496. 1908 «  
 17497—17498. 1920 Scandia

Aftagelig endevæg

Last 15000 kg  
 Bundfl. 18,0 m<sup>2</sup>  
 Tara ca. 7000 kg  
 Trykluftledning  
 Rangerskruebremse

Følgende vogne anvendes til lokale transporter: nr. 14137, 14177, 14230, 14792, 14926.

**798 Litra PFR** 14020, 14021, 14022, 14023, 14024, 14025, 14026, 14027, 14028, 14029, 14030, 14031,  
 14032, 14033, 14034, 14035, 14036, 14037, 14038, 14039, 14040, 14041, 14042, 14043, 14044, 14047, 14048,  
 14049, 14050, 14051, 14053, 14054, 14055, 14056, 14057, 14058, 14059, 14060, 14062, 14063, 14064, 14065,  
 14067, 14068, 14069, 14070, 14071, 14072, 14073, 14074, 14076, 14077, 14079, 14080, 14082, 14083, 14084,  
 14085, 14086, 14087, 14088, 14089, 14090, 14092, 14094, 14096, 14099, 14100, 14101, 14102, 14103, 14104,  
 14106, 14107, 14108, 14109, 14110, 14112, 14113, 14115, 14116, 14117, 14119, 14120, 14121, 14122, 14123,  
 14125, 14126, 14127, 14128, 14129, 14130, 14131, 14132, 14133, 14134, 14137, 14138, 14141, 14144, 14146,  
 14148, 14150, 14151, 14152, 14153, 14154, 14155, 14156, 14157, 14158, 14160, 14163, 14165, 14166, 14171,  
 14172, 14176, 14177, 14179, 14180, 14181, 14182, 14183, 14184, 14185, 14186, 14187, 14188, 14189, 14190,  
 14191, 14194, 14195, 14197, 14198, 14199, 14201, 14202, 14205, 14206, 14207, 14209, 14210, 14211, 14213,  
 14214, 14215, 14216, 14218, 14219, 14220, 14221, 14222, 14223, 14224, 14225, 14226, 14228, 14229, 14230,  
 14231, 14234, 14237, 14239, 14240, 14241, 14242, 14243, 14244, 14245, 14246, 14247, 14248, 14250, 14251,  
 14252, 14254, 14255, 14256, 14257, 14258, 14260, 14261, 14263, 14264, 14265, 14267, 14268, 14271, 14272,  
 14273, 14274, 14275, 14276, 14277, 14279, 14281, 14283, 14284, 14285, 14286, 14288, 14289, 14291, 14293,  
 14294, 14295, 14297, 14301, 14302, 14303, 14305, 14307, 14309, 14310, 14311, 14312, 14313, 14314, 14315,  
 14316, 14317, 14318, 14320, 14321, 14322, 14323, 14325, 14328, 14329, 14332, 14333, 14334, 14335, 14336,  
 14337, 14339, 14340, 14342, 14343, 14344, 14345, 14347, 14348, 14351, 14352, 14355, 14356, 14357, 14358,  
 14359, 14360, 14362, 14363, 14365, 14366, 14367, 14368, 14370, 14371, 14373, 14374, 14375, 14376, 14377,  
 14379, 14380, 14381, 14382, 14383, 14384, 14385, 14386, 14389, 14390, 14391, 14392, 14394, 14395, 14396,  
 14398, 14399, 14401, 14404, 14406, 14407, 14408, 14409, 14413, 14414, 14415, 14417, 14418, 14419, 14420,  
 14424, 14425, 14426, 14427, 14429, 14430, 14431, 14432, 14433, 14434, 14435, 14436, 14437, 14438, 14439,  
 14440, 14441, 14443, 14444, 14445, 14447, 14449, 14450, 14451, 14452, 14456, 14457, 14458, 14459, 14460,  
 14461, 14462, 14463, 14464, 14466, 14467, 14468, 14469, 14470, 14471, 14472, 14473, 14474, 14475, 14476,  
 14477, 14478, 14479, 14480, 14481, 14482, 14483, 14484, 14485, 14486, 14487, 14488, 14489, 14490, 14492,  
 14493, 14495, 14496, 14497, 14498, 14499, 14500, 14501, 14502, 14503, 14504, 14505, 14506, 14507, 14508,  
 14509, 14510, 14511, 14512, 14513, 14514, 14515, 14516, 14517, 14518, 14520, 14521, 14522, 14523, 14524,  
 14525, 14527, 14528, 14529, 14532, 14535, 14536, 14537, 14538, 14539, 14541, 14542, 14543, 14544, 14545,  
 14546, 14547, 14548, 14550, 14552, 14554, 14555, 14556, 14557, 14558, 14559, 14560, 14561, 14563, 14564,  
 14565, 14566, 14567, 14570, 14571, 14574, 14575, 14576, 14578, 14579, 14580, 14581, 14584, 14585, 14586,  
 14588, 14589, 14590, 14591, 14592, 14594, 14596, 14597, 14599, 14601, 14602, 14603, 14604, 14605, 14606,  
 14608, 14609, 14610, 14611, 14612, 14613, 14614, 14615, 14616, 14618, 14619, 14620, 14622, 14623, 14624,  
 14626, 14628, 14630, 14634, 14635, 14636, 14637, 14640, 14641, 14642, 14643, 14645, 14646, 14647, 14648,  
 14650, 14652, 14653, 14655, 14656, 14657, 14659, 14660, 14661, 14662, 14663, 14664, 14665, 14666, 14668,  
 14670, 14671, 14672, 14674, 14675, 14677, 14680, 14681, 14682, 14683, 14684, 14685, 14687, 14689, 14690,  
 14691, 14692, 14695, 14696, 14699, 14700, 14701, 14702, 14703, 14704, 14705, 14706, 14707, 14708, 14709,  
 14710, 14711, 14712, 14713, 14714, 14715, 14716, 14717, 14718, 14719, 14720, 14721, 14722, 14723, 14724,  
 14725, 14726, 14727, 14728, 14729, 14730, 14731, 14732, 14733, 14734, 14735, 14736, 14737, 14738, 14739,  
 14740, 14741, 14745, 14746, 14747, 14748, 14749, 14750, 14751, 14752, 14753, 14754, 14755, 14756, 14757,  
 14758, 14759, 14762, 14763, 14764, 14765, 14766, 14767, 14768, 14770, 14771, 14773, 14774, 14775, 14776,  
 14777, 14778, 14779, 14782, 14783, 14784, 14785, 14786, 14787, 14788, 14789, 14791, 14792, 14793, 14795,  
 14797, 14798, 14799, 14801, 14803, 14804, 14805, 14806, 14808, 14809, 14811, 14812, 14813, 14814, 14817,  
 14820, 14821, 14825, 14826, 14827, 14828, 14829, 14830, 14831, 14832, 14834, 14835, 14838, 14839, 14840,  
 14843, 14844, 14845, 14846, 14850, 14851, 14853, 14854, 14855, 14856, 14857, 14858, 14860, 14861, 14862,  
 14863, 14864, 14865, 14866, 14867, 14869, 14872, 14873, 14874, 14875, 14878, 14880, 14882, 14883, 14884,  
 14887, 14889, 14890, 14891, 14892, 14893, 14894, 14895, 14896, 14898, 14900, 14901, 14902, 14903, 14904,  
 14905, 14906, 14907, 14908, 14911, 14914, 14916, 14918, 14920, 14921, 14923, 14925, 14926, 14927, 14929,  
 14930, 14931, 14932, 14933, 14935, 14936, 14939, 14940, 14941, 14942, 14943, 14945, 14946, 14948, 14951,  
 14952, 14954, 14955, 14956, 14957, 14958, 14959, 14961, 14962, 14963, 14964, 14965, 14967, 14968, 14969,  
 14970, 14971, 14973, 14975, 14978, 14979, 14981, 14983, 14984, 14985, 14986, 14987, 14988, 14989, 14991,  
 14993, 14994, 14995, 14996, 14997, 14998, 14999, 15000, 15001, 15002, 15004, 15005, 15006, 15007, 15010,  
 15012, 15015, 15017, 15018, 15020, 15021, 15023, 15024, 15029, 15030, 15033, 15034, 15035, 15036, 15037,  
 15039, 15041, 15042, 15043, 15044, 15046, 15047, 15048, 15050, 15051, 15054, 15055, 15057, 15059, 15060,  
 15061, 15063, 15064, 15065, 15066, 15067, 15068, 15069, 15071, 15072, 15073, 15074, 15076, 15077, 15079,  
 17493, 17494, 17495, 17496, 17497, 17498.

141 **Litra PH nr.** 7508, 7509, 7510, 7511, 7513, 7515, 7516, 7517, 7518, 7519, 7520, 7521, 7522, 7523, 7524, 7525, 7527, 7528, 7531, 7532, 7533, 7534, 7536, 7537, 7538, 7539, 7541, 7542, 7543, 7544, 7545, 7546, 7547, 7548, 7549, 7550, 7551, 7552, 7553, 7554, 7555, 7556, 7557, 7558, 7559, 7560, 7561, 7562, 7563, 7564, 7565, 7566, 7567, 7568, 7569, 7570, 7572, 7574, 7576, 7577, 7578, 7580, 7581, 7583, 7584, 7585, 7586, 7587, 7588, 7594, 7595, 7596, 7605, 7609, 7610, 7611, 7612, 7613, 7614, 7615, 7616, 7617, 7618, 7619, 7620, 7621, 7622, 7624, 7629, 7630, 7631, 7632, 7637, 7639, 7640, 7641, 7644, 7647, 7649, 7651, 7652, 7653, 7654, 7656, 7657, 7658, 7659, 7662, 7664, 7666, 7667, 7669, 7671, 7673, 7675, 7676, 7677, 7678, 7680, 7681, 7684, 7685, 7686, 7688, 7690, 7692, 7695, 7697, 7698, 7700, 7702, 7743, 7744, 7745, 7746, 7747, 7748, 7749, 7750, 7751, 7752.

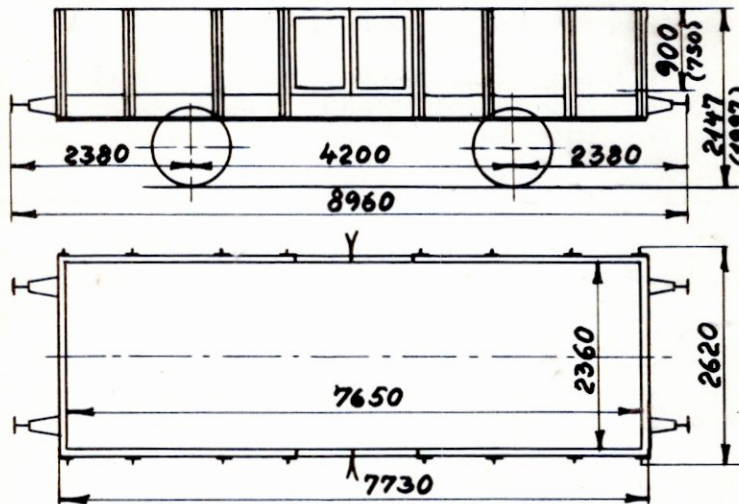

7508—7520. 1906 Scandia  
 7521—7527. 1915 «  
 7528—7534. 1907 «  
 7536—7539. 1914 «  
 7541—7542. 1918 «  
 7543—7345. 1919 «  
     7546. 1920 «  
 7547—7559. 1911 «  
 7560—7563. 1912 «  
 7564—7565. 1914 «  
 7566—7567. 1915 «  
     7568. 1919 «  
 7569—7577. 1910 «  
 7578—7585. 1911 «  
 7586—7587. 1918 «  
     7588. 1916 «  
     7594. 1910 «  
 7595—7596. 1912 «  
 7605, 7609. 1917 «  
 7610—7613. 1918 «  
 7614—7617. 1916 «  
 7618—7620. 1911 «  
 7621—7673. 1891 «  
 7675—7702. 1893 «  
 7743—7752. « «

Målene i ( ) gælder for 7508—7520

Aftagelige endevægge

Last 12500 kg  
 Bundfl. 18,0 m<sup>2</sup>  
 Tara ca. 6400 kg  
 Trykluftledning  
 Håndbremse

Følgende vogne anvendes til lokale transporter: nr. 7750,

. Kbs 333 0 000-333 0 449

RIV - POOL

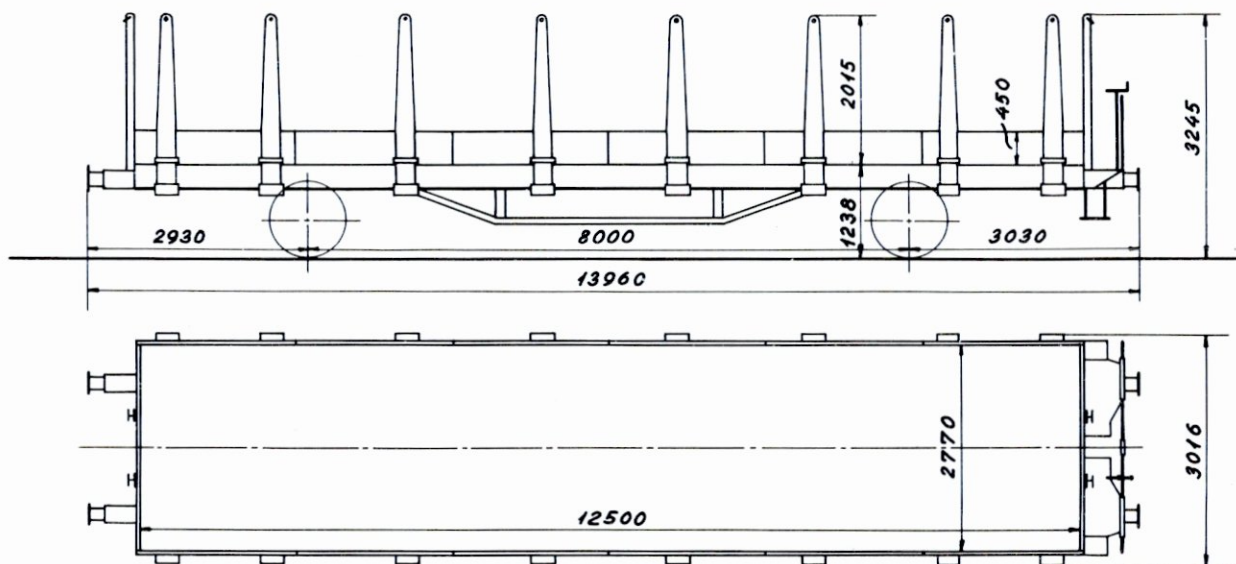

1958/65 Scandia

Bundflade 34,6 m<sup>2</sup>

	A	B	C
	19,5t	23,5t	27,5t
S	19,5t	23,5t	

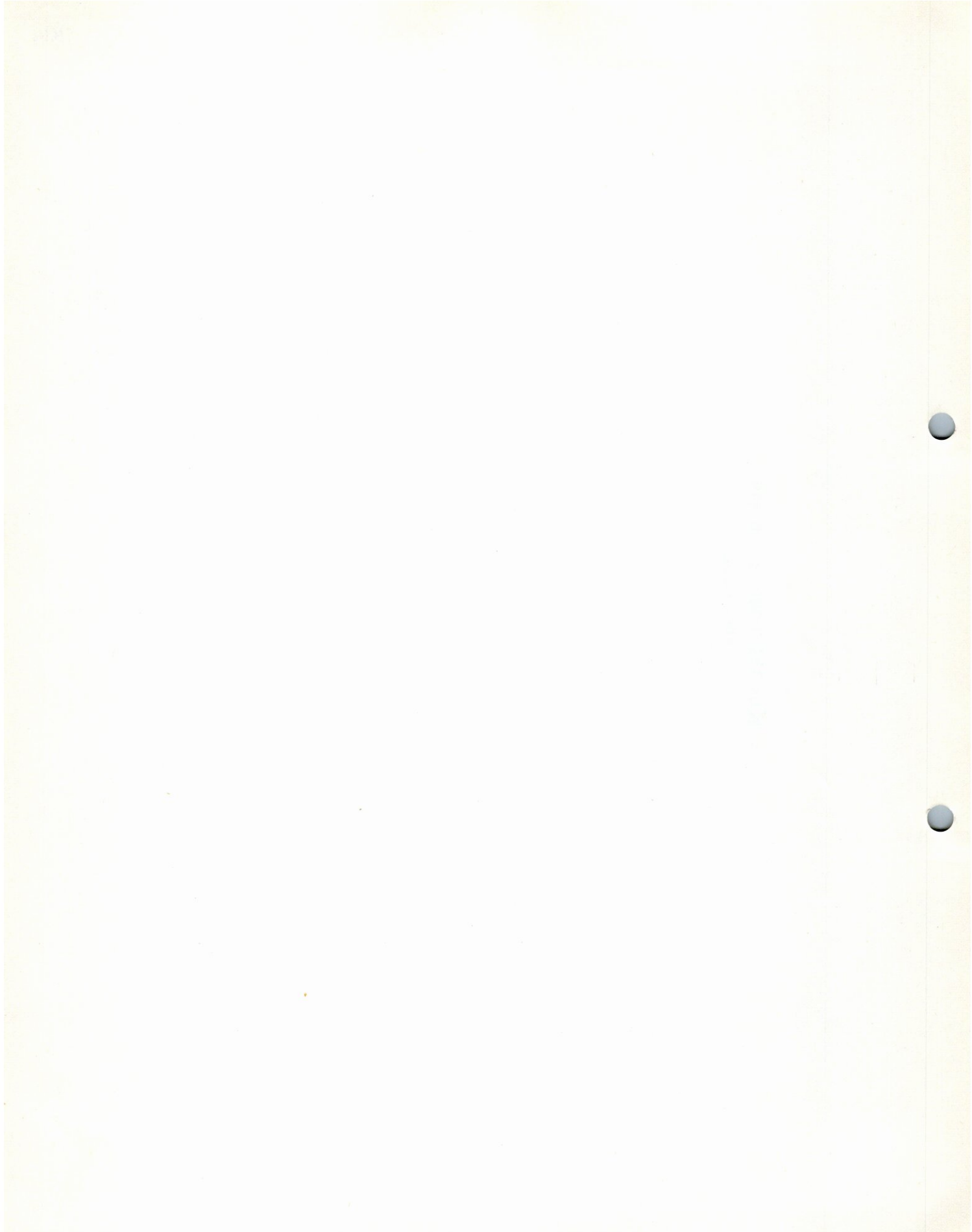



29 **Litra PHR nr.** 7703, 7704, 7705, 7706, 7710, 7716, 7718, 7720, 7721, 7722, 7723, 7724, 7725, 7726, 7727, 7728, 7730, 7731, 7732, 7733, 7734, 7735, 7738, 7754, 7755, 7756, 7757, 7758, 7759.

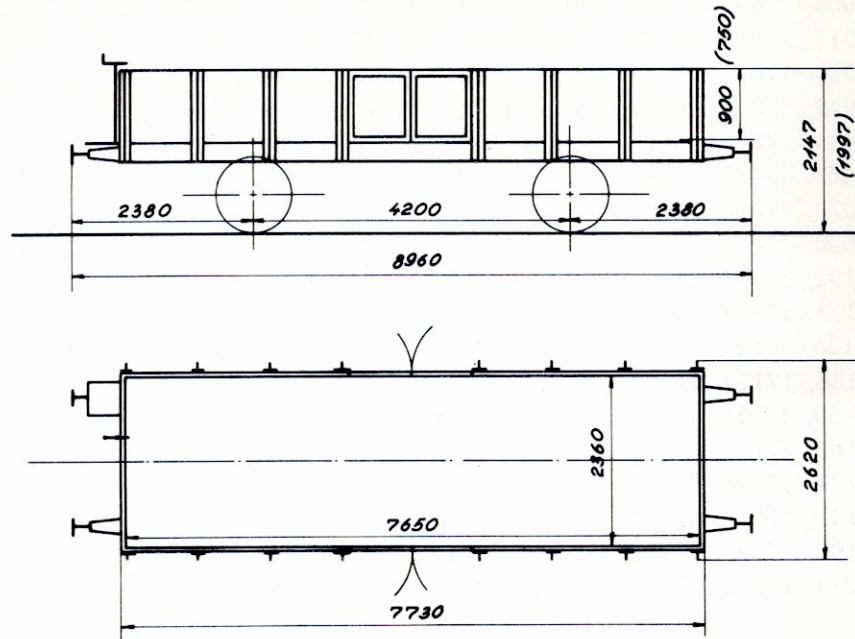

7703—7710. 1893 Scandia  
 7716—7733. 1891 «  
 7734—7738. 1893 «  
 7754. 1914 «  
 7755. 1918 «  
 7756. 1919 «  
 7757. 1918 «  
 7758, 7759. 1906 «

Målene i ( ) gælder for 7758—7759

Aftagelig endevæg

Last 12500 kg  
 Bundfl. 18,0 m<sup>2</sup>  
 Tara ca. 6700 kg  
 Trykluftledning  
 Rangierskruebremse

246 **Litra Pj** nr. 16970, 16971, 16972, 16973, 16974, 16975, 16976, 16977, 16978, 16979, 16980, 16981, 16982, 16983, 16984, 16985, 16986, 16987, 16988, 16989, 16990, 16991, 16992, 16993, 16994, 16996, 16997, 16998, 16999, 17000, 17001, 17002, 17003, 17004, 17005, 17006, 17007, 17008, 17009, 17010, 17011, 17012, 17013, 17014, 17015, 17016, 17017, 17018, 17019, 17020, 17021, 17022, 17024, 17025, 17026, 17027, 17028, 17029, 17030, 17031, 17032, 17033, 17034, 17035, 17036, 17037, 17038, 17039, 17040, 17041, 17042, 17043, 17044, 17045, 17046, 17047, 17048, 17049, 17050, 17051, 17052, 17053, 17054, 17055, 17056, 17057, 17058, 17059, 17060, 17061, 17062, 17063, 17064, 17065, 17066, 17067, 17068, 17069, 17070, 17071, 17072, 17073, 17074, 17075, 17076, 17077, 17078, 17079, 17080, 17081, 17082, 17083, 17084, 17085, 17086, 17087, 17088, 17089, 17090, 17091, 17092, 17093, 17094, 17095, 17096, 17097, 17098, 17099, 17100, 17101, 17102, 17103, 17104, 17105, 17106, 17107, 17108, 17109, 17110, 17111, 17112, 17113, 17114, 17115, 17116, 17117, 17118, 17119, 17120, 17121, 17122, 17123, 17124, 17125, 17126, 17127, 17128, 17129, 17130, 17131, 17132, 17133, 17134, 17135, 17136, 17137, 17138, 17139, 17140, 17141, 17142, 17143, 17144, 17145, 17146, 17147, 17148, 17149, 17150, 17151, 17152, 17153, 17154, 17155, 17156, 17157, 17158, 17159, 17160, 17161, 17162, 17163, 17164, 17165, 17166, 17167, 17168, 17169, 17170, 17171, 17172, 17173, 17174, 17175, 17176, 17178, 17179, 17180, 17181, 17182, 17183, 17184, 17185, 17186, 17187, 17188, 17189, 17190, 17191, 17192, 17193, 17194, 17195, 17196, 17197, 17198, 17199, 17201, 17202, 17203, 17204, 17205, 17206, 17207, 17208, 17209, 17210, 17211, 17212, 17213, 17214, 17215, 17216, 17217, 17218, 17219.

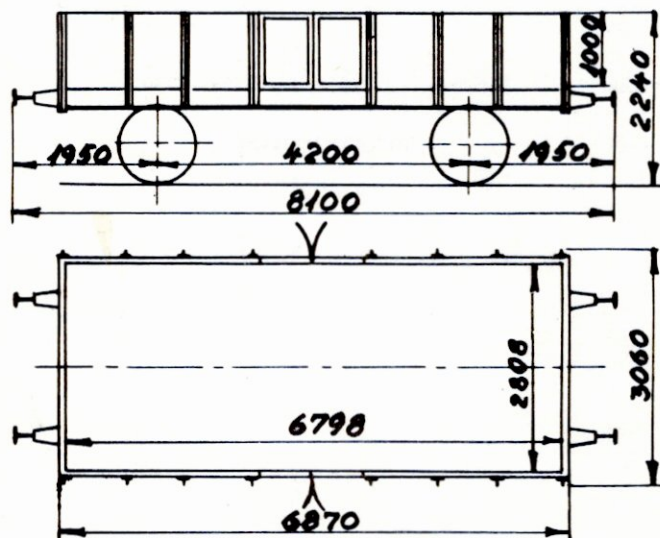

16970—17144. 1922 Scandia  
 17145—17204. 1923 «  
 17205—17218. 1924 «  
 17219. 1942 «

Aftagelige endevægge

Last 15000 kg  
 Bundfl. 19,0 m<sup>2</sup>  
 Tara ca. 7400 kg  
 Trykluftledning  
 Håndbremse

317 **litra PJB** nr. 16620, 16621, 16622, 16623, 16624, 16626, 16627, 16629, 16630, 16631, 16632, 16633, 16634, 16635, 16636, 16638, 16639, 16640, 16641, 16642, 16643, 16644, 16645, 16646, 16647, 16648, 16649, 16650, 16651, 16652, 16654, 16655, 16656, 16657, 16658, 16659, 16660, 16661, 16662, 16663, 16664, 16665, 16666, 16667, 16669, 16670, 16671, 16672, 16673, 16674, 16675, 16676, 16677, 16678, 16679, 16680, 16681, 16682, 16683, 16684, 16685, 16686, 16687, 16688, 16689, 16691, 16692, 16694, 16695, 16696, 16697, 16698, 16699, 16700, 16701, 16702, 16703, 16704, 16705, 16706, 16707, 16708, 16709, 16710, 16711, 16712, 16713, 16714, 16715, 16716, 16717, 16718, 16719, 16720, 16721, 16722, 16723, 16724, 16725, 16727, 16729, 16730, 16731, 16732, 16733, 16734, 16737, 16738, 16739, 16740, 16741, 16742, 16743, 16744, 16745, 16746, 16747, 16748, 16749, 16750, 16751, 16752, 16753, 16754, 16755, 16756, 16758, 16760, 16761, 16762, 16763, 16764, 16765, 16766, 16767, 16768, 16769, 16770, 16771, 16772, 16774, 16775, 16776, 16777, 16778, 16779, 16780, 16781, 16782, 16783, 16784, 16785, 16787, 16788, 16789, 16790, 16791, 16792, 16793, 16794, 16795, 16796, 16797, 16798, 16799, 16800, 16801, 16802, 16803, 16804, 16805, 16806, 16807, 16808, 16809, 16811, 16812, 16813, 16814, 16815, 16817, 16818, 16819, 16821, 16822, 16823, 16824, 16825, 16826, 16827, 16828, 16829, 16831, 16832, 16833, 16834, 16835, 16836, 16837, 16838, 16839, 16840, 16841, 16842, 16843, 16844, 16845, 16846, 16847, 16848, 16849, 16850, 16851, 16852, 16853, 16854, 16855, 16856, 16857, 16858, 16859, 16861, 16862, 16863, 16864, 16865, 16866, 16867, 16868, 16869, 16870, 16872, 16873, 16874, 16875, 16876, 16877, 16878, 16879, 16880, 16881, 16882, 16883, 16884, 16885, 16886, 16887, 16888, 16890, 16891, 16892, 16895, 16897, 16898, 16899, 16900, 16901, 16902, 16903, 16904, 16905, 16906, 16908, 16909, 16910, 16911, 16912, 16913, 16914, 16915, 16916, 16918, 16919, 16920, 16921, 16922, 16924, 16926, 16927, 16928, 16930, 16931, 16932, 16933, 16935, 16936, 16937, 16938, 16939, 16940, 16941, 16942, 16943, 16944, 16945, 16946, 16947, 16948, 16949, 16950, 16951, 16953, 16954, 16955, 16956, 16957, 16959, 16960, 16961, 16962, 16963, 16964, 16965, 16966, 16967, 16968, 16969.

16620—16744. 1920 Scandia  
 15745—16901. 1921 »  
 16902—16969. 1922 »

Last 15000 kg  
 Bundflade 19,0 m<sup>2</sup>  
 Tara ca. 8500 kg  
 Trykluftbremse (G)  
 Håndbremse

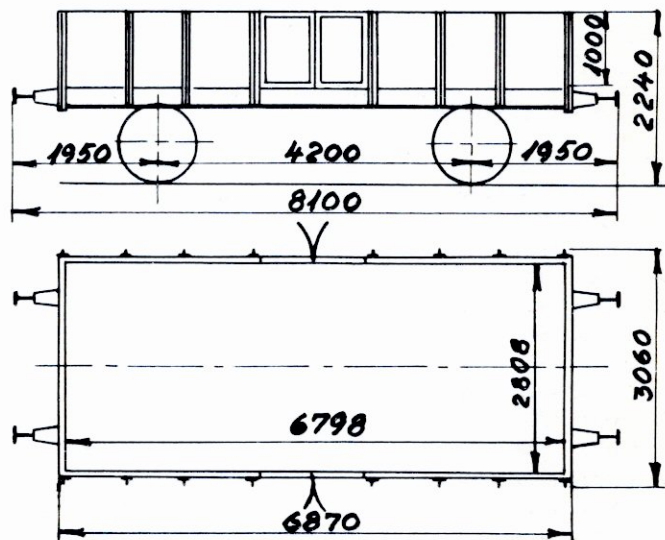

Aftagelige endevægge

200 **litra PJR** nr. 13784, 13785, 13786, 13787, 13788, 13789, 13790, 13791, 13792, 13793, 13794, 13795, 13796, 13798, 13799, 13800, 13801, 13802, 13804, 13805, 13806, 13807, 13808, 13810, 13811, 13812, 13814, 13815, 13816, 13817, 13818, 13820, 13821, 13822, 13823, 13824, 13825, 13826, 13827, 13828, 13829, 13830, 13831, 13832, 13833, 13834, 13836, 13837, 13839, 13840, 13841, 13842, 13843, 13845, 13846, 13847, 13848, 13849, 13850, 13851, 13852, 13853, 13854, 13854, 13857, 13858, 13859, 13861, 13863, 13864, 13865, 13866, 13867, 13868, 13869, 13870, 13871, 13872, 13873, 13874, 13875, 13876, 13878, 13879, 13881, 13882, 14883, 13888, 13891, 13892, 13893, 13895, 13896, 13897, 13898, 13899, 13900, 13901, 13902, 13905, 13906, 13907, 13908, 13909, 13910, 13911, 13912, 13913, 13914, 13915, 13916, 13917, 13918, 13919, 13920, 13921, 13923, 13924, 13925, 13926, 13927, 13928, 13931, 13932, 13933, 13934, 13935, 13936, 13937, 13938, 13940, 13942, 13943, 13944, 13945, 13946, 13947, 13948, 13949, 13950, 13952, 13953, 13954, 13955, 13956, 13957, 13958, 13960, 13961, 13962, 13963, 13964, 13965, 13966, 13967, 13968, 13969, 13970, 13971, 13972, 13974, 13975, 13976, 13977, 13979, 13980, 13981, 13982, 13983, 13984, 13986, 13987, 13988, 13989, 13990, 13991, 13992, 13993, 13994, 13995, 13997, 13999, 14000, 14001, 14002, 14004, 14006, 14007, 14008, 14009, 14010, 14011, 14012, 14013, 14014, 14015, 14016, 14017, 14018, 14019.

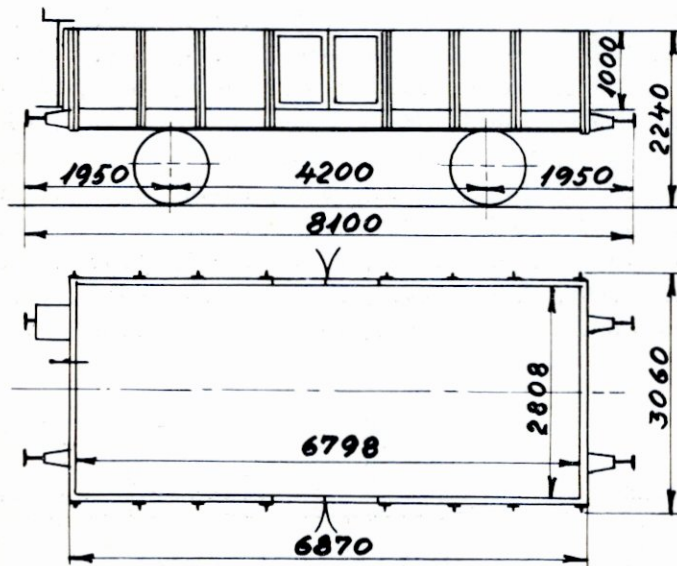

13784.	1924	Scandia
13785—13834.	1922	»
13836—13837.	1924	»
13839—13942.	1922	»
13843—13846.	1924	»
13847—13849.	1922	»
13850.	1924	»
13851—13866.	1922	»
13867—13871.	1924	»
13872.	1922	»
13873—13881.	1924	»
13882.	1922	»
13884.	1924	»
13888.	1922	»
13891—13938.	1924	»
13940—13969.	1921	»
13970—14019.	1920	»

Aftagelig endevæg

Last 15000 kg

Bundflade 19,0 m<sup>2</sup>

13784: Tara ca. 7100 kg

Øvrige: Tara ca. 8200 kg

13784: Trykluftledning

Øvrige: Trykluftbremse (G)

Rangerskruebremse

• **Kklm 323 0 101 - 323 0 121**  
RIV

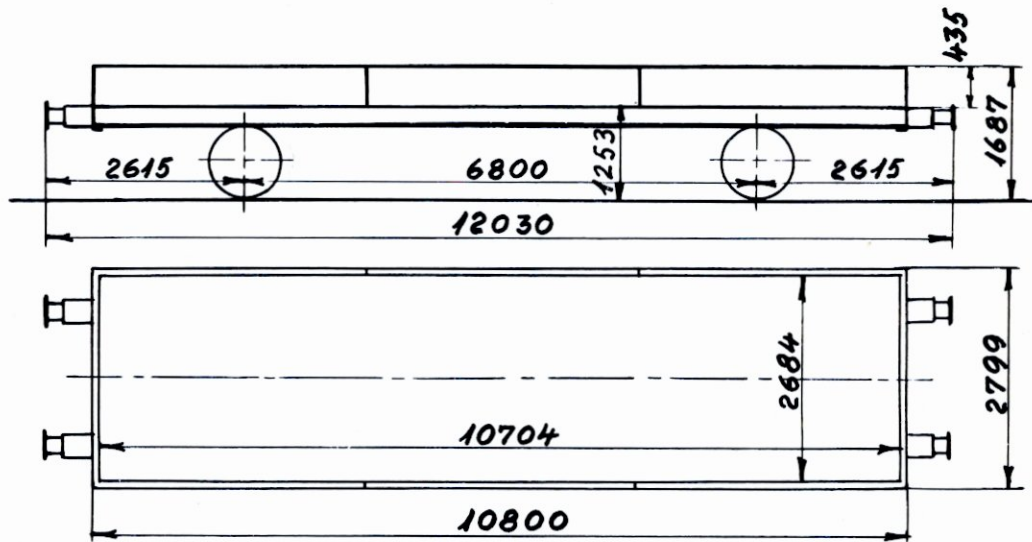

1947 Scandia

Bundflade 28,8 m<sup>2</sup>

A	B	C
17,5 t		

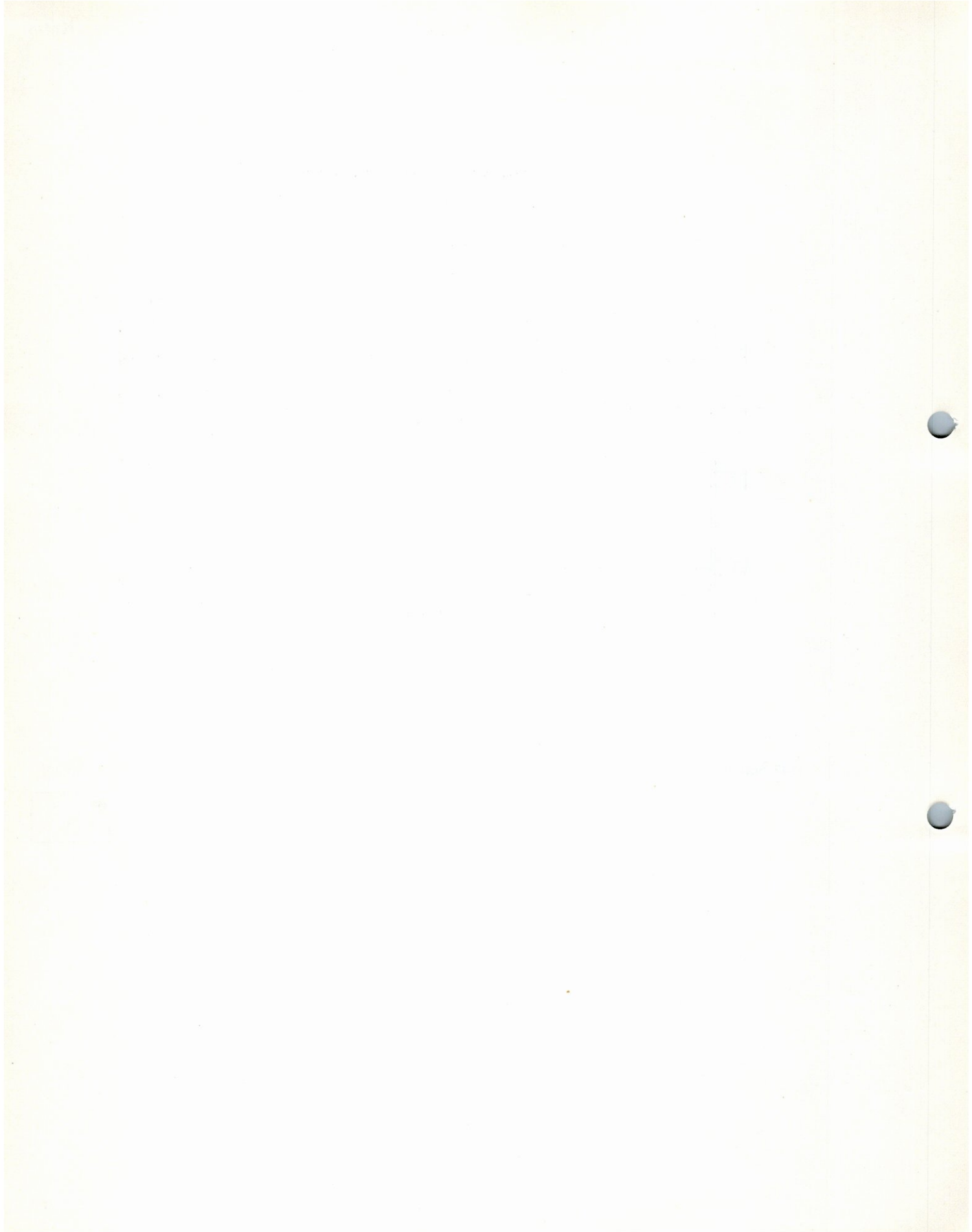

. **Ks 330 0 000 - 330 0 299**

**RIV - POOL**

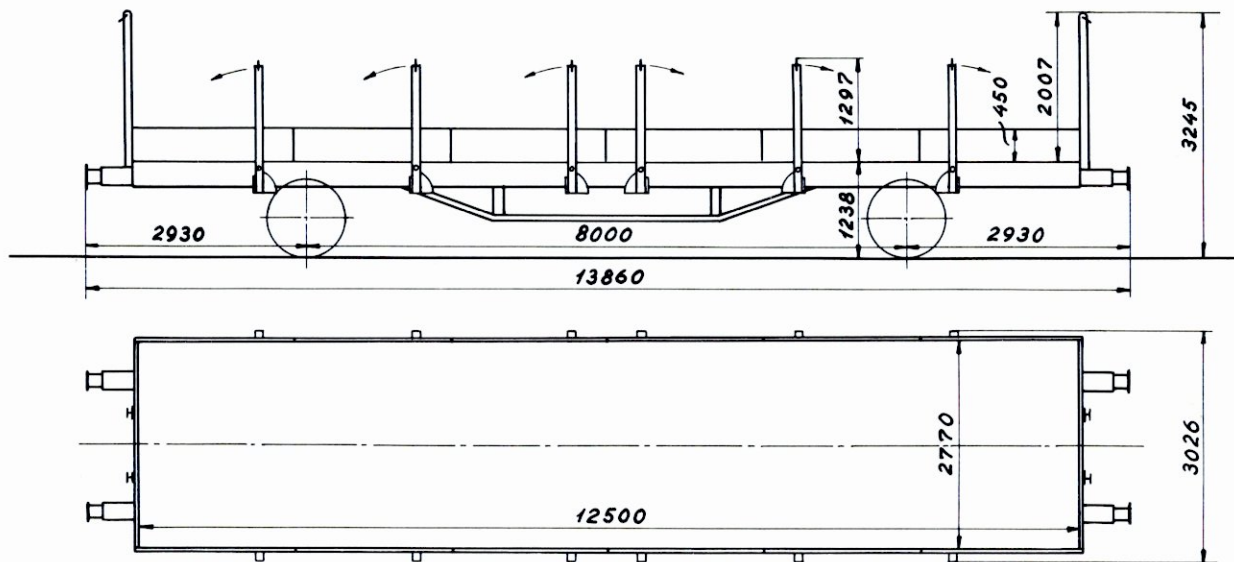

1967/68 Scandia

Bundflade 34,6 m<sup>2</sup>

	A	B	C
	19,5t	23,5t	27,5t
S	19,5t	23,5t	





110 **Litra PT nr.** 9469, 9470, 9471, 9472, 9473, 9474, 9475, 9476, 9477, 9479, 9480, 9481, 9482, 9483, 9485, 9486, 9487, 9488, 9489, 9490, 9491, 9492, 9493, 9494, 9495, 9496, 9497, 9499, 9500, 9501, 9502, 9503, 9504, 9505, 9506, 9507, 9508, 9509, 9510, 9511, 9512, 9513, 9514, 9515, 9516, 9517, 9518, 9519, 9520, 9521, 9522, 9523, 9524, 9525, 9526, 9527, 9528, 9529, 9530, 9531, 9532, 9533, 9534, 9535, 9536, 9537, 9538, 9539, 9540, 9541, 9542, 9543, 9544, 9545, 9547, 9548, 9549, 9550, 9551, 9552, 9553, 9554, 9555, 9556, 9557, 9558, 9559, 9560, 9561, 9562, 9563, 9564, 9565, 9568, 9569, 9570, 9571, 9572, 9573, 9574, 9575, 9576, 9577, 9578, 9579, 9580, 9581, 9582, 9583, 9584.

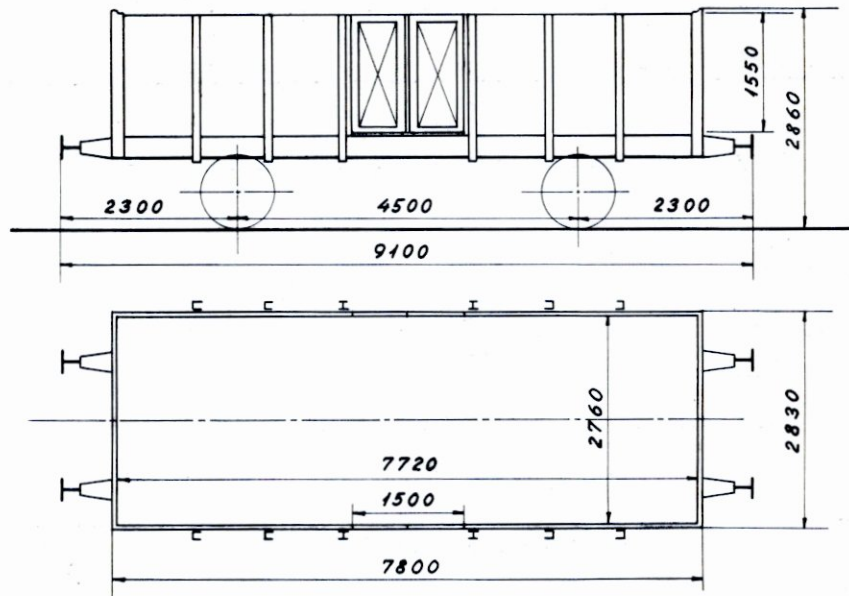

9469. 1920 Dortmund  
9470—9584. 1919 «

Aftagelige endevægge  
Presseningoverdækning

Last 20000 kg  
Bundfl. 21,3 m<sup>2</sup>  
9469—9500 Tara ca. 8600 kg  
« « Trykluftledning  
9501—9584 Tara ca. 9500 kg  
« « Trykluftbremse (G)  
« « Håndbremse

38 **Litra PTR** nr. 9585, 9586, 9587, 9588, 9589, 9590, 9591, 9592, 9593, 9594, 9595, 9596, 9598, 9599, 9600, 9601, 9602, 9603, 9604, 9605, 9606, 9607, 9608, 9609, 9610, 9611, 9612, 9613, 9614, 9615, 9616, 9617, 9618, 9619, 9620, 9621, 9623, 9624.

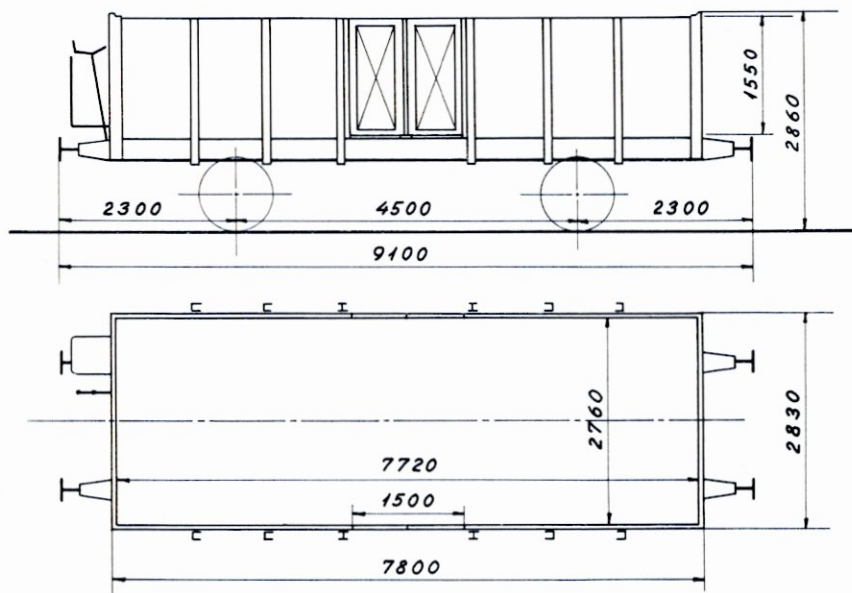

1919 Dortmund

Aftagelig endevæg  
Pressenningoverdækning

Last 20000 kg  
Bundfl. 21,3 m<sup>2</sup>  
Tara ca. 9500 kg  
Trykluftbremse (G)  
Rangerskruebremse

1 Litra PKR nr. 9707.

41 Litra PTR nr. 9625, 9626, 9627, 9628, 9629, 9630, 9631, 9632, 9633, 9634,  
9635, 9636, 9637, 9638, 9639, 9640, 9641, 9642, 9643, 9644, 9645, 9646,  
9647, 9648, 9649, 9650, 9651, 9652, 9653, 9654, 9655, 9656, 9657, 9658,  
9659, 9660, 9661, 9662, 9663, 9664, 9665.

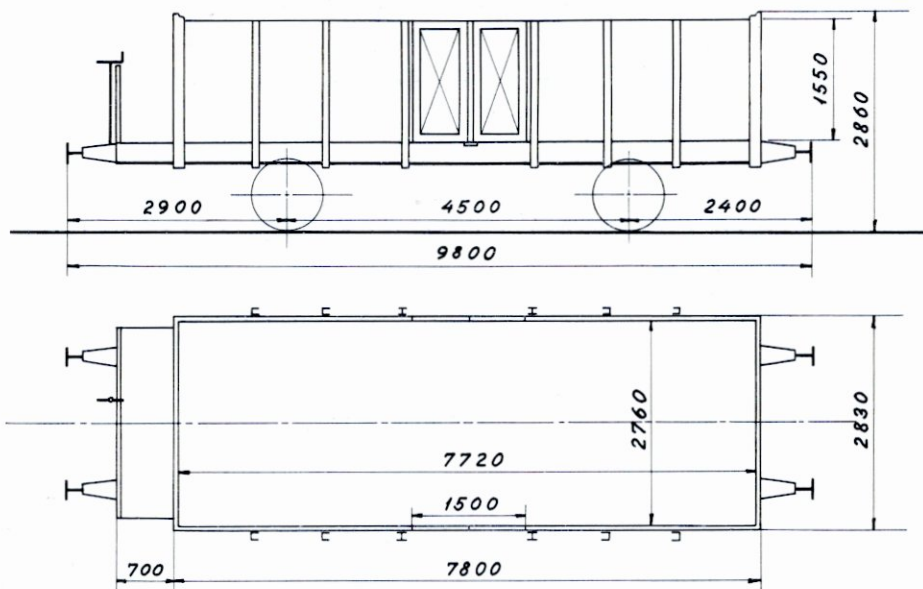

9625—9642. 1919 Dortmund  
9643—9653. 1920 «  
9654—9663. 1919 «  
9664—9665. 1920 «  
9707. 1921 Oberbedarf

Aftagelig endevæg  
Presseningoverdækning

Last 20000 kg  
Bundfl. 21,3 m<sup>2</sup>  
Tara ca. 9700 kg  
Trykluftbremse (G)  
Rangerskruebremse

PKR. Tara ca. 9500 kg  
Trykluftledning

- 29 **Litra PU** nr. 9906, 9907, 9908, 9909, 9910, 9912, 9913, 9914, 9915, 9916, 9917, 9918, 9919, 9924, 9928, 9929, 9930, 9931, 9935, 9937, 9939, 9941, 9942, 9943, 9945, 9946, 9947, 9948, 9951.

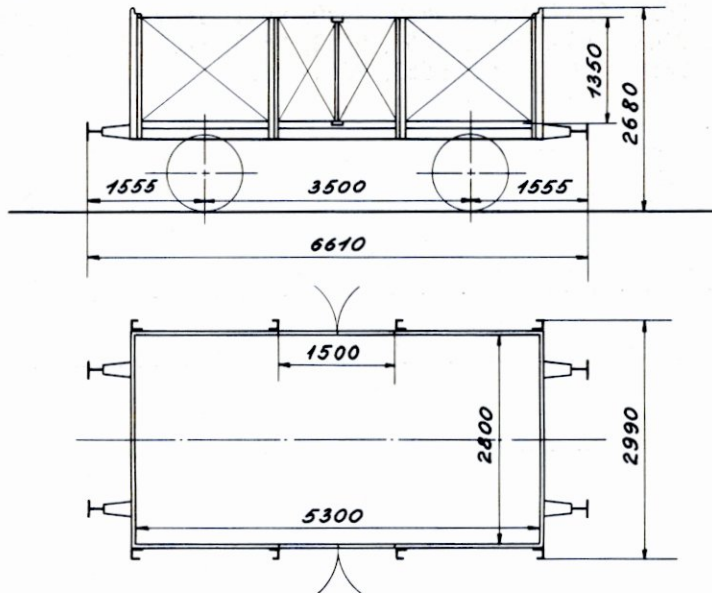

1919 Harkort-Duisburg

Aftagelige endevægge  
Kun til spec. transp.

Last 20000 kg  
Bundfl. 14,8 m<sup>2</sup>  
Tara ca. 7600 kg  
Trykluftledning  
Håndbremse

- 11 **Litra PUR** nr. 9888, 9890, 9891, 9892, 9893, 9894, 9895, 9897, 9898, 9899, 9900.

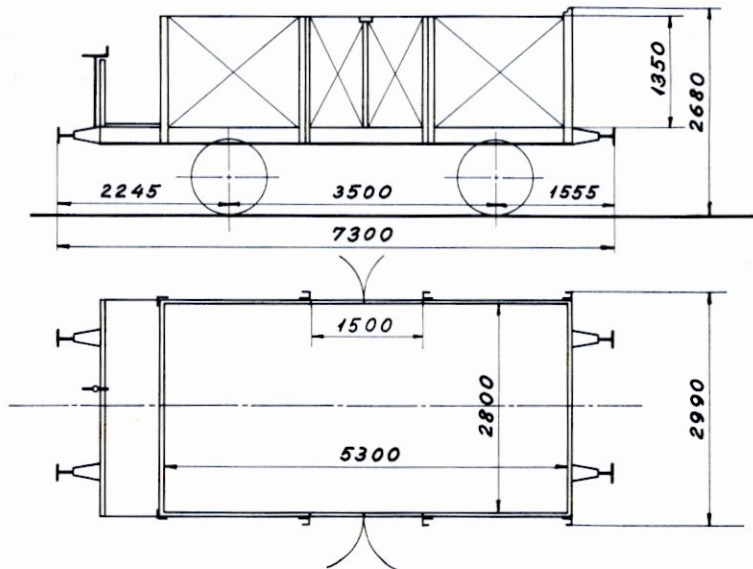

1919 Harkort-Duisborg

Aftagelig endevæg  
Kun til spec. transp.

Last 20000 kg  
Bundfl. 14,8 m<sup>2</sup>  
Tara ca. 8500 kg  
Trykluftledning  
Rangerskruebremse

23 **Litra Ps** nr. 9711, 9712, 9713, 9714, 9715, 9716, 9717, 9718, 9719, 9720, 9721, 9722, 9723, 9724, 9725, 9726, 9727, 9728, 9729, 9730, 9731, 9732, 9733.

3 **Litra PSR** nr. 9797, 9798, 9799.

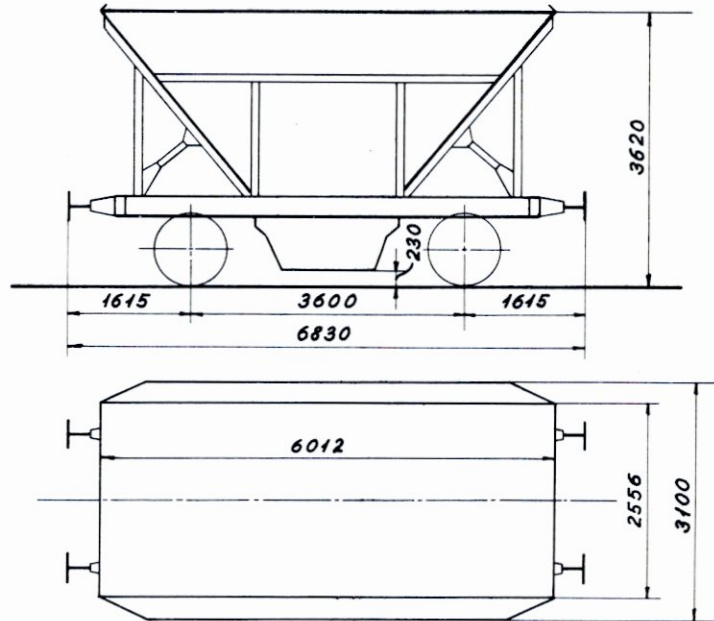

9711—9716. 1928 Scandia—Arlöv  
 9717—9722. 1929 « «  
 9723—9726. 1931 « «  
 9727—9728. 1939 « «  
 9729—9733. 1941 Scandia—København  
 9797—9799. « « «

Selvtømmende kultransportvogne  
 Bevægelige bundlemme  
 Kun til spec. transporter

9711—9722. Last 20000 kg  
 9723—9733 } « 18000 «  
 9797—9799 }  
 9711—9726. Tara ca. 9400 kg  
 9727—9728. « « 10200 «  
 9729—9733. « « 9600 «  
 9797—9799. « « 10300 «  
 9711—9733. Håndbremse  
 9797—9799. Rangerskruebremse  
 Trykluftledning

## 6 Litra Pv nr. 9801, 9802, 9803, 9804, 9805, 9806.

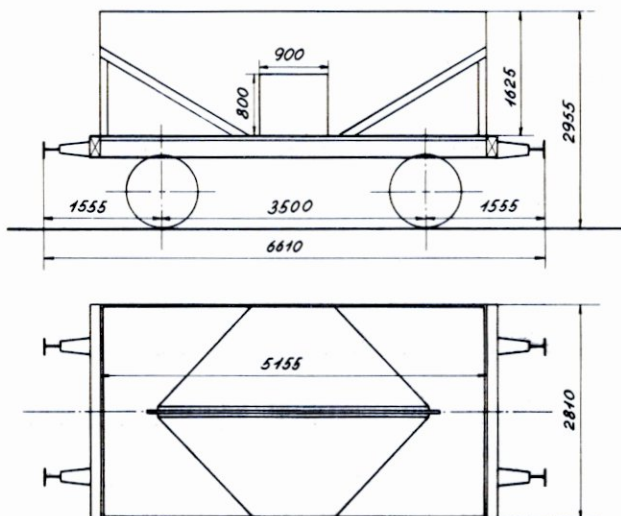

1920 Harkort—Duisborg  
Ombygget 1951 København

Kultransportvogn

Tara ca. 7800 kg  
Last 15000 kg  
Trykluftledning  
Håndbremse

## 1 Litra Pv nr. 9807.

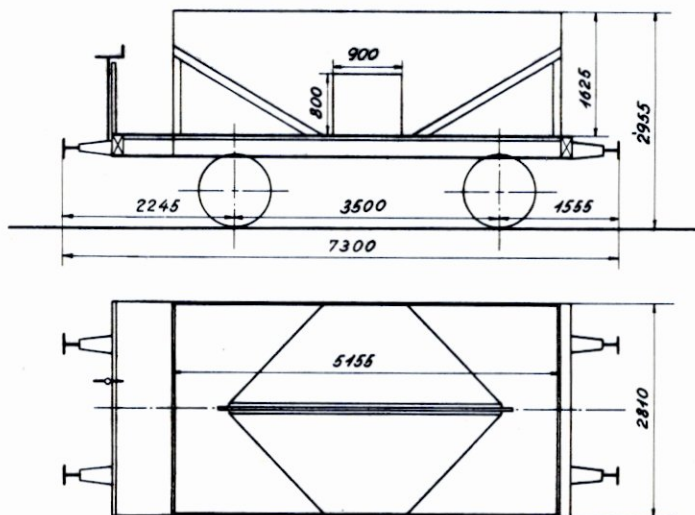

1920 Harkort—Duisborg  
Ombygget 1951 København

Kultransportvogn

Tara ca. 8700 kg  
Last 15000 kg  
Trykluftledning  
Rangerskruebremse

# Litra Ks

RIV

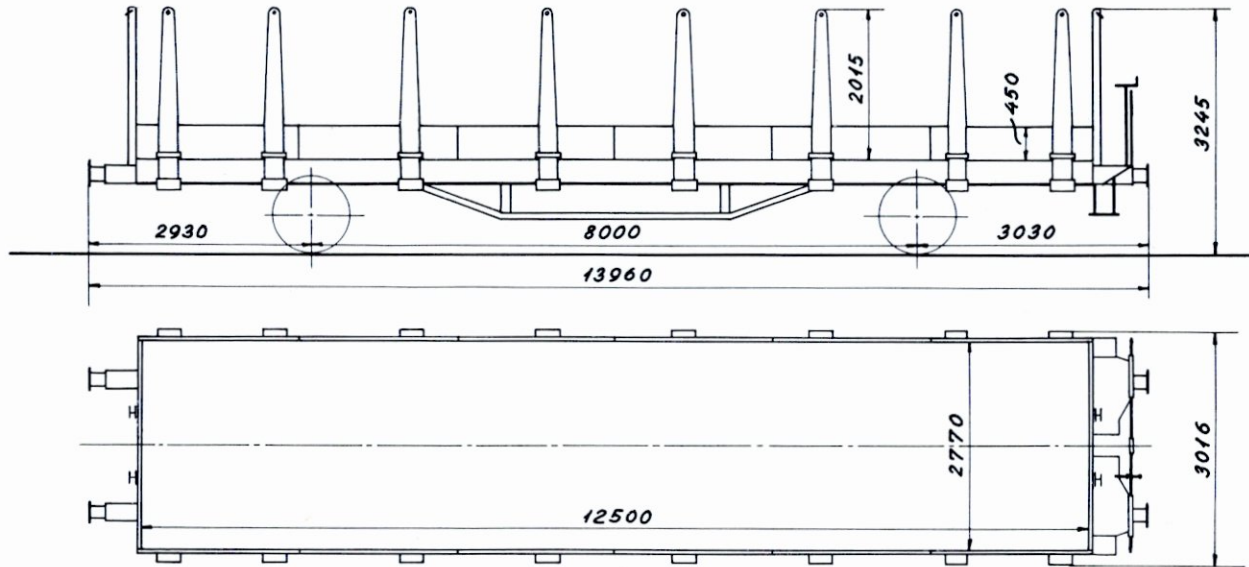

Bundflade 34,6 m<sup>2</sup>

	A	B	C
	19,5 t	23,5 t	27,5 t
S	19,5 t	23,5 t	

63-IV

KS



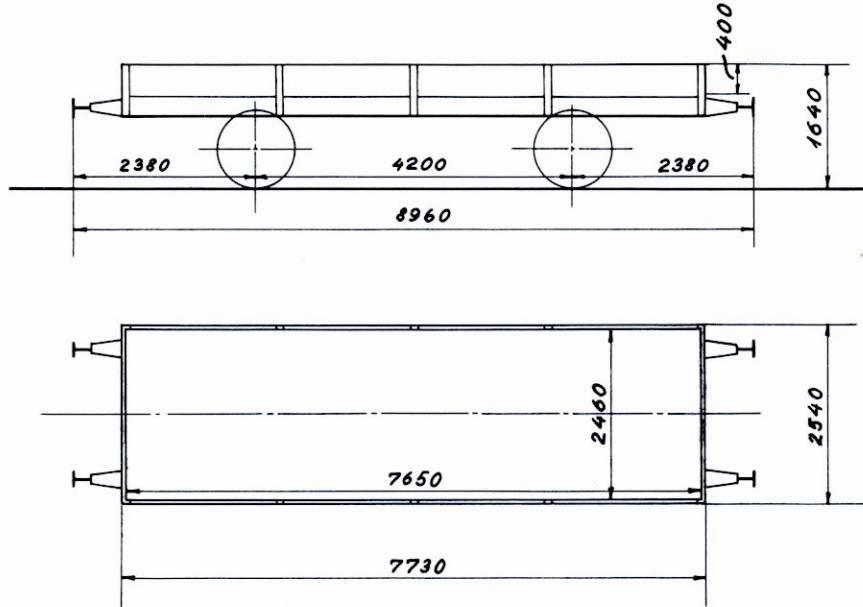

## Litra TB

Bundflade 18,8 m<sup>2</sup>

A	B	C
15,5 t	15,5 t	

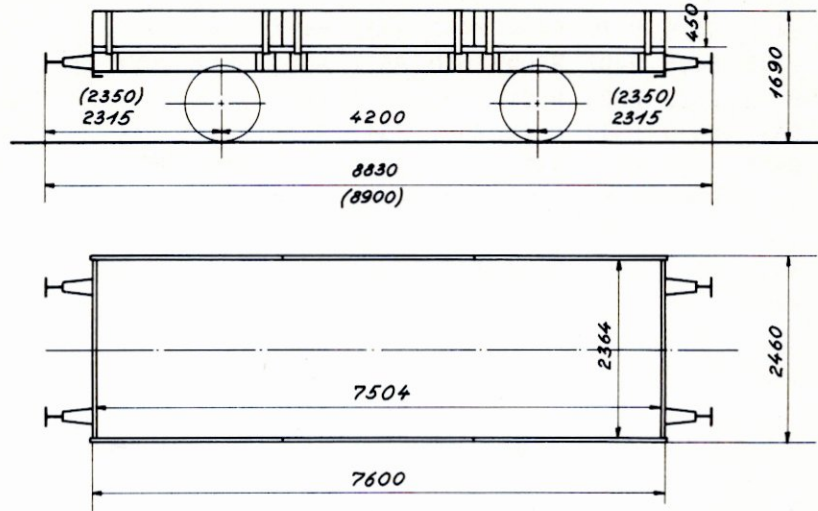

**6 Litra Tc nr. 8201—8206**

8201—8205. 1924 Scandia  
8206. 1923 Hawa

Målene i ( ) gælder 8206  
Aftagelige endevægge  
Sidevæggene er delt i 3  
om hængsler drejelige  
dele

Last 15000 kg  
Bundfl. 17,7 m<sup>2</sup>  
Tara ca. 6700 kg  
Trykluftledning  
Håndbremse

**50 Litra Td nr.** 8499, 8501, 8502, 8503, 8504, 8505, 8506, 8507, 8751, 8752, 8753, 8755, 8756, 8757, 8758, 8759, 8760, 8761, 8762, 8763, 8764, 8765, 8766, 8767, 8768, 8770, 8771, 8772, 8773, 8774, 8775, 8776, 8777, 8778, 8779, 8780, 8781, 8782, 8783, 8784, 8785, 8786, 8787, 8788, 8789, 8790, 8791, 8792, 8793, 8794.

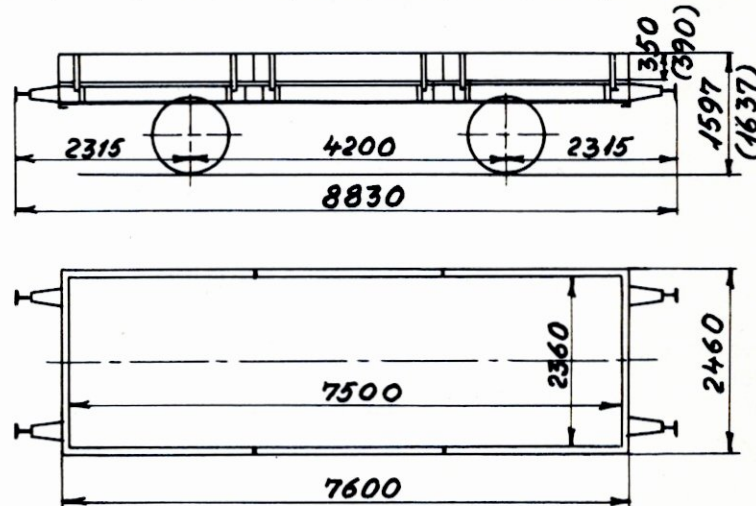

8499, 8501—8507 1888 Scandia  
8751—8794 1907 «

Aftagelige endevægge  
Sidevæggene er delt i 3 om  
hængsler drejelige dele  
Mål i ( ) gælder for 8751—8770

Last 12500 kg  
Bundfl. 17,7 m<sup>2</sup>  
Tara ca. 6100 kg  
Trykluftledning  
Håndbremse

279 **Litra Td nr.** 8445, 8446, 8447, 8448, 8449, 8450, 8451, 8452, 8453, 8454, 8455, 8456, 8458, 8459, 8460, 8461, 8462, 8463, 8464, 8466, 8467, 8468, 8471, 8473, 8475, 8476, 8477, 8478, 8479, 8480, 8481, 8482, 8483, 8484, 8486, 8487, 8488, 8489, 8491, 8493, 8494, 8495, 8497, 8509, 8510, 8511, 8512, 8513, 8514, 8515, 8516, 8517, 8518, 8519, 8520, 8522, 8523, 8524, 8525, 8526, 8527, 8528, 8529, 8531, 8532, 8534, 8535, 8536, 8537, 8538, 8539, 8540, 8541, 8542, 8543, 8544, 8545, 8546, 8547, 8548, 8549, 8551, 8553, 8554, 8555, 8556, 8557, 8558, 8559, 8560, 8561, 8562, 8563, 8564, 8565, 8566, 8567, 8568, 8569, 8570, 8571, 8572, 8573, 8574, 8575, 8576, 8577, 8578, 8579, 8580, 8581, 8582, 8583, 8584, 8585, 8586, 8587, 8588, 8589, 8590, 8591, 8592, 8593, 8594, 8595, 8596, 8597, 8598, 8599, 8600, 8601, 8602, 8603, 8604, 8605, 8606, 8607, 8608, 8609, 8610, 8611, 8612, 8613, 8614, 8615, 8616, 8617, 8618, 8619, 8620, 8621, 8622, 8623, 8624, 8625, 8626, 8627, 8628, 8629, 8630, 8631, 8632, 8633, 8634, 8635, 8636, 8637, 8638, 8639, 8640, 8641, 8642, 8643, 8644, 8645, 8646, 8647, 8648, 8649, 8650, 8651, 8652, 8653, 8654, 8655, 8656, 8657, 8658, 8659, 8660, 8661, 8662, 8663, 8664, 8665, 8666, 8667, 8668, 8669, 8670, 8671, 8672, 8673, 8674, 8675, 8676, 8677, 8678, 8679, 8680, 8681, 8682, 8683, 8684, 8685, 8686, 8687, 8688, 8689, 8690, 8691, 8692, 8693, 8694, 8695, 8696, 8697, 8698, 8699, 8700, 8701, 8702, 8703, 8704, 8705, 8706, 8707, 8708, 8709, 8710, 8711, 8712, 8713, 8715, 8716, 8717, 8718, 8719, 8720, 8721, 8722, 8723, 8724, 8725, 8726, 8727, 8728, 8729, 8730, 8731, 8732, 8733, 8734, 8735, 8736, 8737, 8738, 8739, 8740, 8741, 8742, 8743, 8744, 8745, 8746, 8747, 8748, 8749, 4750.

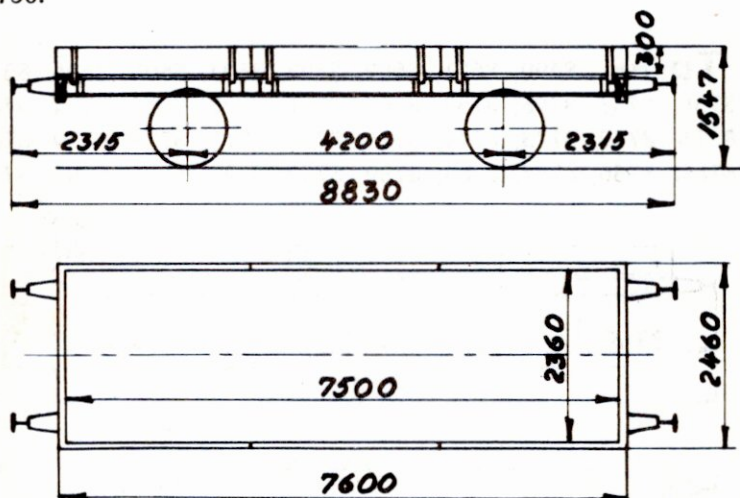

8445—8452. 1924 Scandia  
 8453—8462. 1918 «  
 8463—8468. 1912 «  
     8471. 1913 «  
 8473—8482. 1909 «  
 8483—8497. 1883 Breslau  
 8509—8542. 1883 «  
 8543—8558. 1846 Scandia  
 8559—8600. 1909 «  
 8601—8650. 1910 «  
 8651—8680. 1912 «  
 8681—8710. 1918 «  
 8711—8750. 1924 «

Aftagelige endevægge  
 Sidevæggene er delt i 3  
 om hængsler drejelige  
 dele

Last 12500 kg  
 Bundfl. 17,7 m<sup>2</sup>  
 Tara ca. 6300 kg  
 Trykluftledning  
 Håndbremse

**8 Litra TD nr. 18001, 18002, 18003, 18004, 18005, 18006, 18007, 18008.**

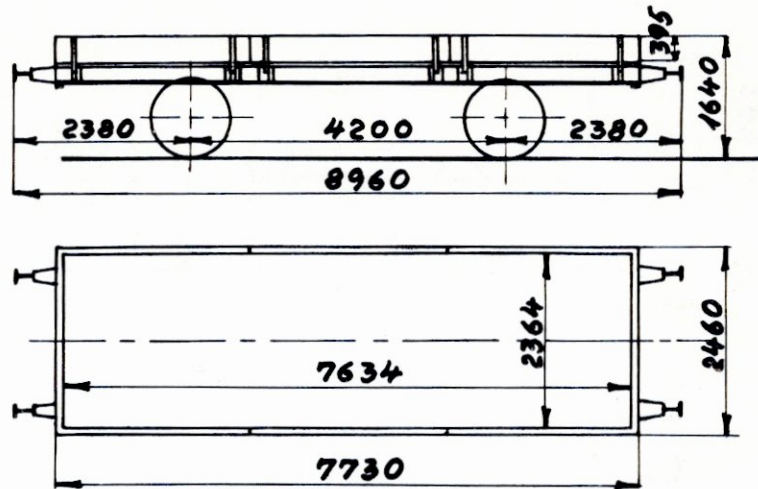

1916 Scandia

Aftagelige endevægge  
Sidevæggene er delt i 3  
om hængsler drejelige  
dele

Last 12500 kg  
Bundfl. 18,1 m<sup>2</sup>  
Tara ca. 6400 kg  
Trykluftledning  
Håndbremse

**10 Litra TDB nr. 8433, 8434, 8435, 8436, 8437, 8438, 8439, 8440, 8441, 8442.**

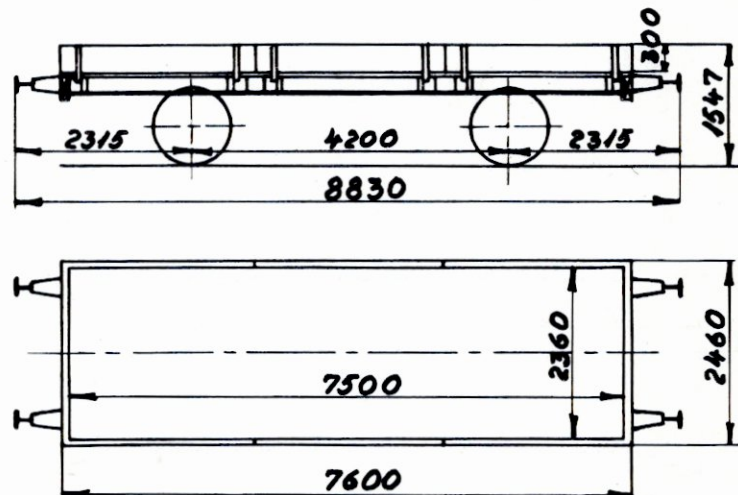

1924 Scandia

Aftagelige endevægge  
Sidevæggene er delt i 3  
om hængsler drejelige  
dele

Last 12500 kg  
Bundfl. 17,7 m<sup>2</sup>  
Tara ca. 7800 kg  
Trykluftbremse  
Håndbremse

# TDR

68 — III

12 Litra TDR nr. 8443, 8444, 8457, 8465, 8469, 8470, 8472, 8474, 8485, 8490, 8492, 8496.

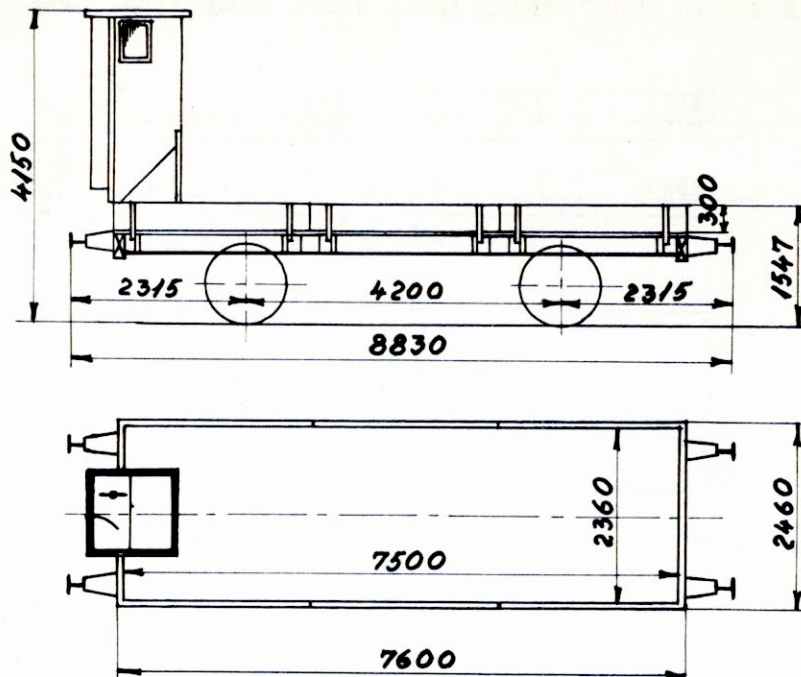

8443, 8444. 1924 Scandia  
 8457. 1918 «  
 8465. 1912 «  
 8469—8472. 1913 «  
 8474. 1909 «  
 8485—8496. 1883 Breslau

Aftagelig endevæg  
 Sidevæggene er delt i 3  
 om hængsler drejelige  
 dele

Last 12500 kg  
 Bundfl. 17,7 m<sup>2</sup>  
 Tara ca. 7100 kg  
 Trykluftledning  
 Skruebremse

## 2 Litra TDR nr. 8498, 8500

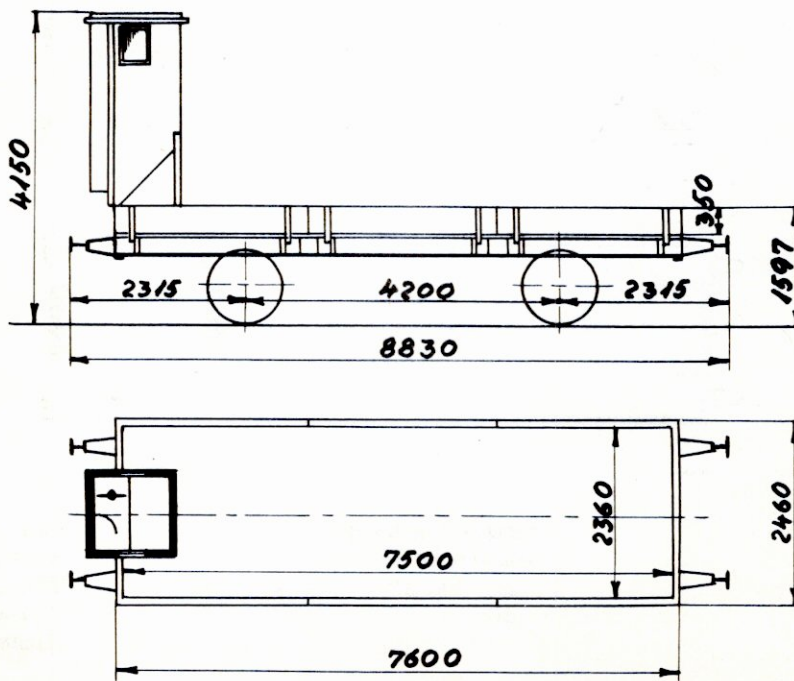

1888 Scandia

Aftagelig endevæg  
 Sidevæggene er delt i 3 om hængsler drejelige dele

Last 12500 kg  
 Bundfl. 17,7 m<sup>2</sup>  
 Tara ca. 6900 kg  
 Trykluftledning  
 Skruebremse

## Litra TF

RIV

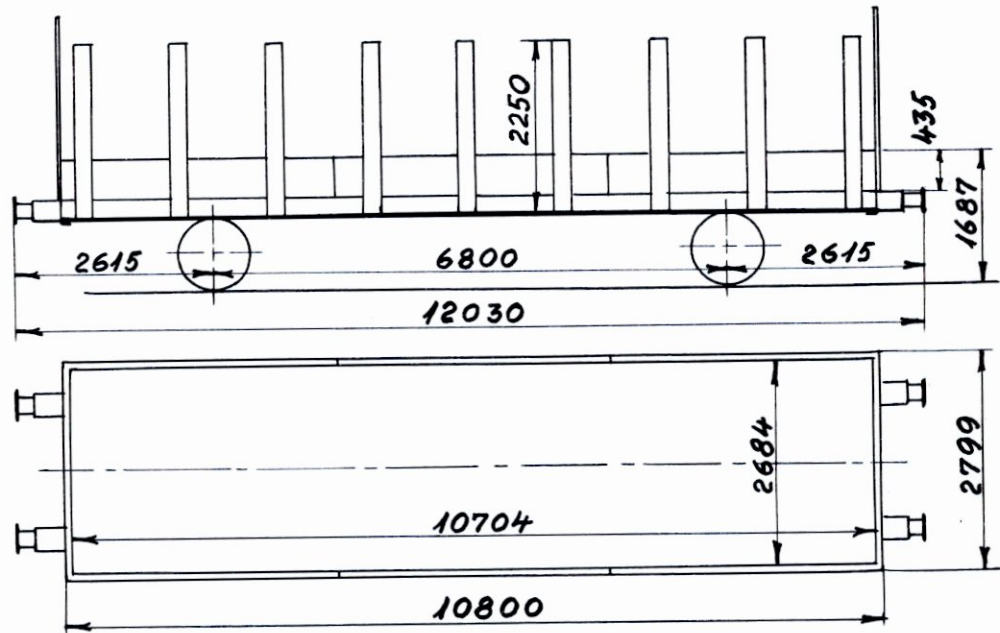
Bundflade 28,8 m<sup>2</sup>

A	B	C
17,5 t	17,5 t	





## 4 Litra TGA nr. 8901—8904

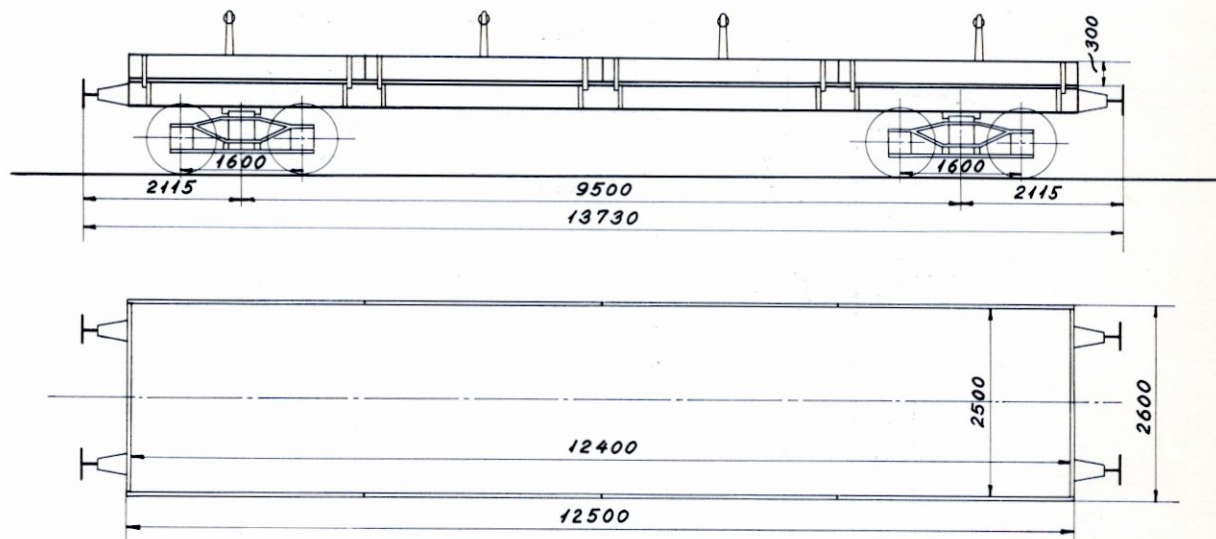

1886 Scandia

Aftagelige sidestolper og endevægge  
 Sidevæggene er delte i 4 om hængsler drejelige dele  
 Må ikke benyttes til forsendelse af gl. sveller til  
 Centralværkstedet i Århus

Last 30000 kg  
 Bundfl. 31,0 m<sup>2</sup>  
 Tara ca. 15500 kg  
 Trykluftledning  
 Håndbremse

## 71 Litra TGC nr. 8905—8975

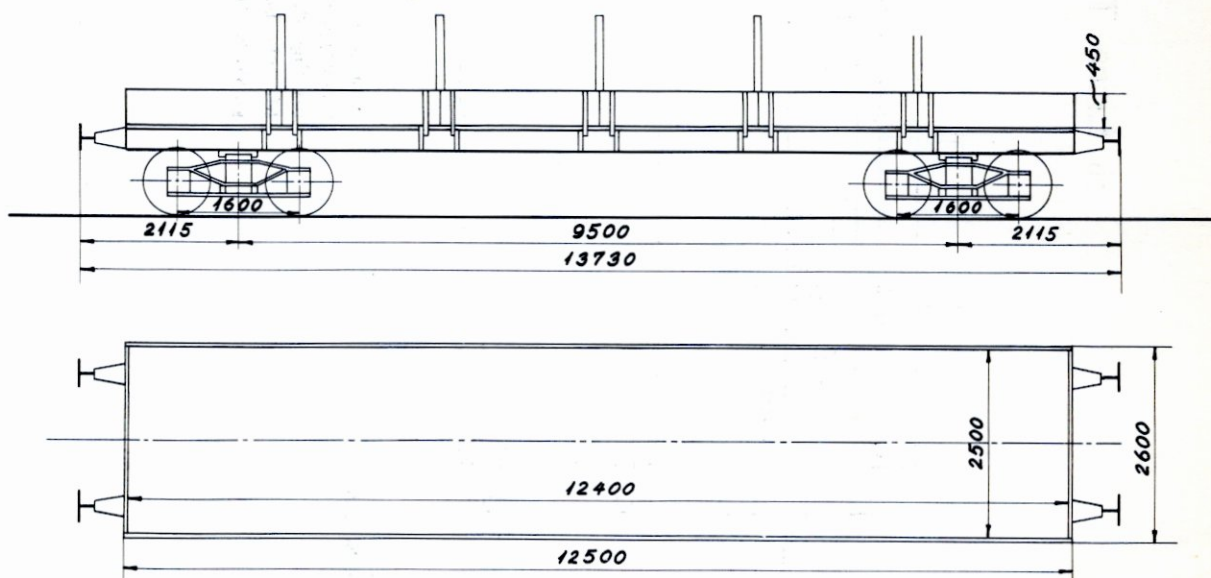

8905—8910. 1896 Skabo  
 8911—8915. 1901 Breslau  
 8916—8920. 1917 Scandia  
 8921—8925. 1918 «  
 8926—8937. 1921 «  
 8938—8955. 1922 «  
 8956—8975. 1927 «

Aftagelige sidestolper og endevægge  
 Sidevæggene er delte i 6 om hængsler  
 drejelige dele  
 Må ikke benyttes til forsendelse af gl.  
 sveller til Centralværkstedet i Århus

Last 30000 kg  
 Bundfl. 31,0 m<sup>2</sup>  
 Tara ca. 16600 kg  
 Trykluftledning  
 Håndbremse

## 20 Litra TGT nr. 8976—8995

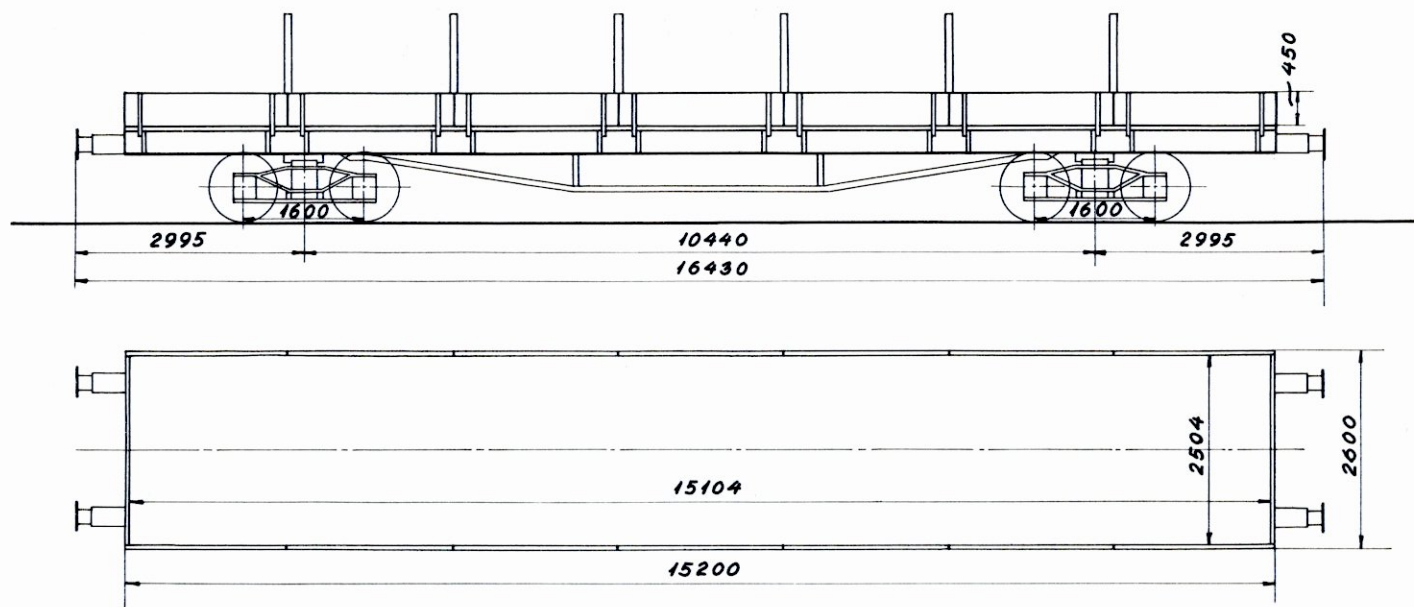

1931 Scandia

Aftagelige sidestolper og endevægge  
 Sidevæggene er delt i 7 om hængsler  
 drejelige dele  
 Må ikke benyttes til forsendelse af  
 gl. sveller til Centralværkstedet i Århus

Last 30000 kg  
 Bundfl. 37,8 m<sup>2</sup>  
 Tara ca. 18500 kg  
 Trykluftledning  
 Håndbremse

40 **Litra TGS** nr. 9201—9240

R.I.V.

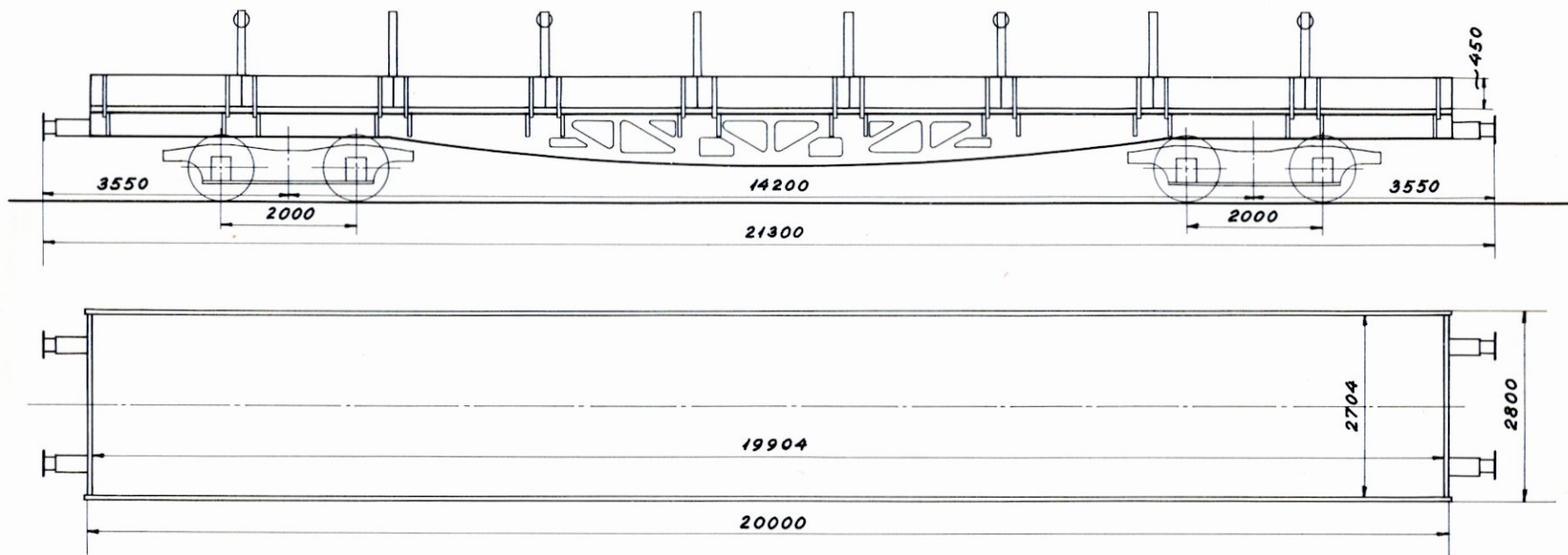

76 a—II

9201—9210. 1941 Scandia  
9211—9240. 1950 «

Aftagelige sidestolper og endevægge  
Sidevæggene er delt i 9 om hængsler  
drejelige dele  
Må ikke benyttes til forsendelse af  
gl. sveller til Centralværkstedet i Århus  
og ikke til forsendelse af halm, hø o. l.  
til udlandet

9211—9240 Kan anvendes til transport af  
skinneudlægningskraner

Last 40000 kg  
Bundfl. 53,8 m<sup>2</sup>  
Tara ca. 23600 kg  
Trykluftbremse (G.)  
Håndbremse



1 litra T<sub>M</sub> nr. 9991

RIV

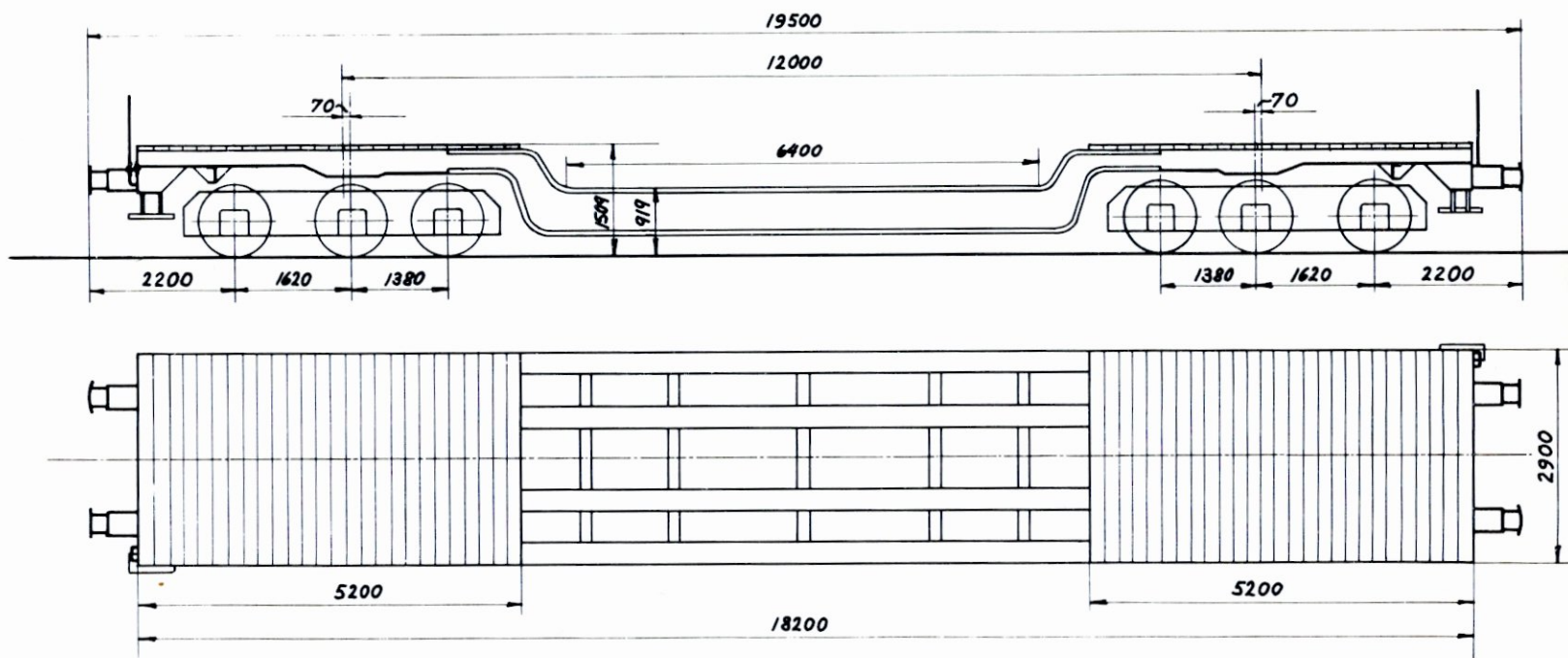

1956. København

Last 45000 kg  
Tara ca. 34300 kg  
Trykluftledning  
Håndbremse

76c-II

T<sub>M</sub>



# Litra Sad

RIV

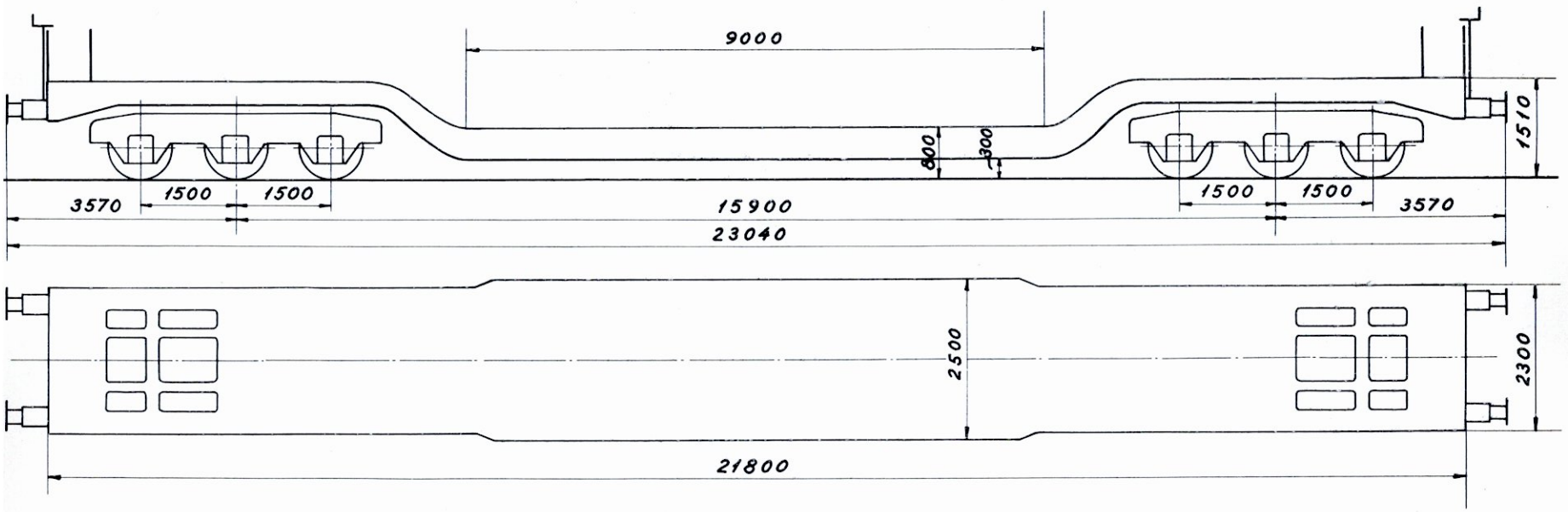

76e-I

Sad

A	B	C
58,5 t	70,5 t	80,0 t

100

11/11/11



**Litra S<sub>d</sub>**  
RIV

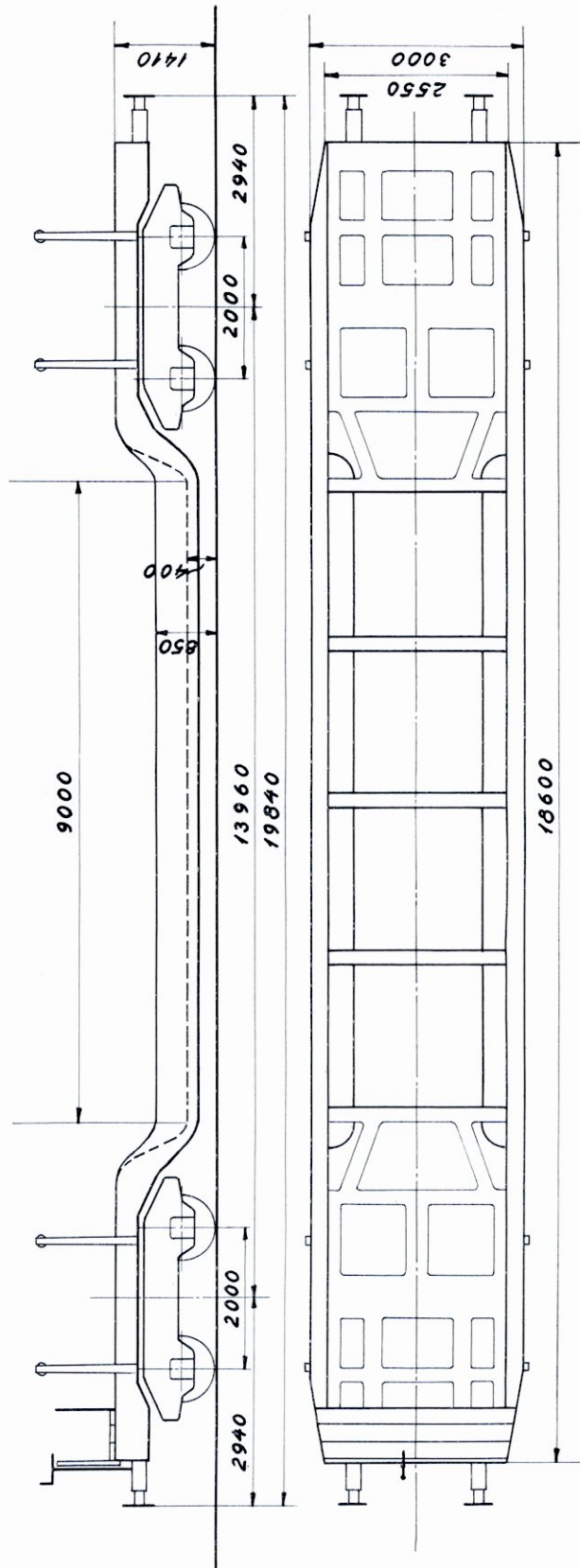

A	B	C
33,4 t		40,0 t

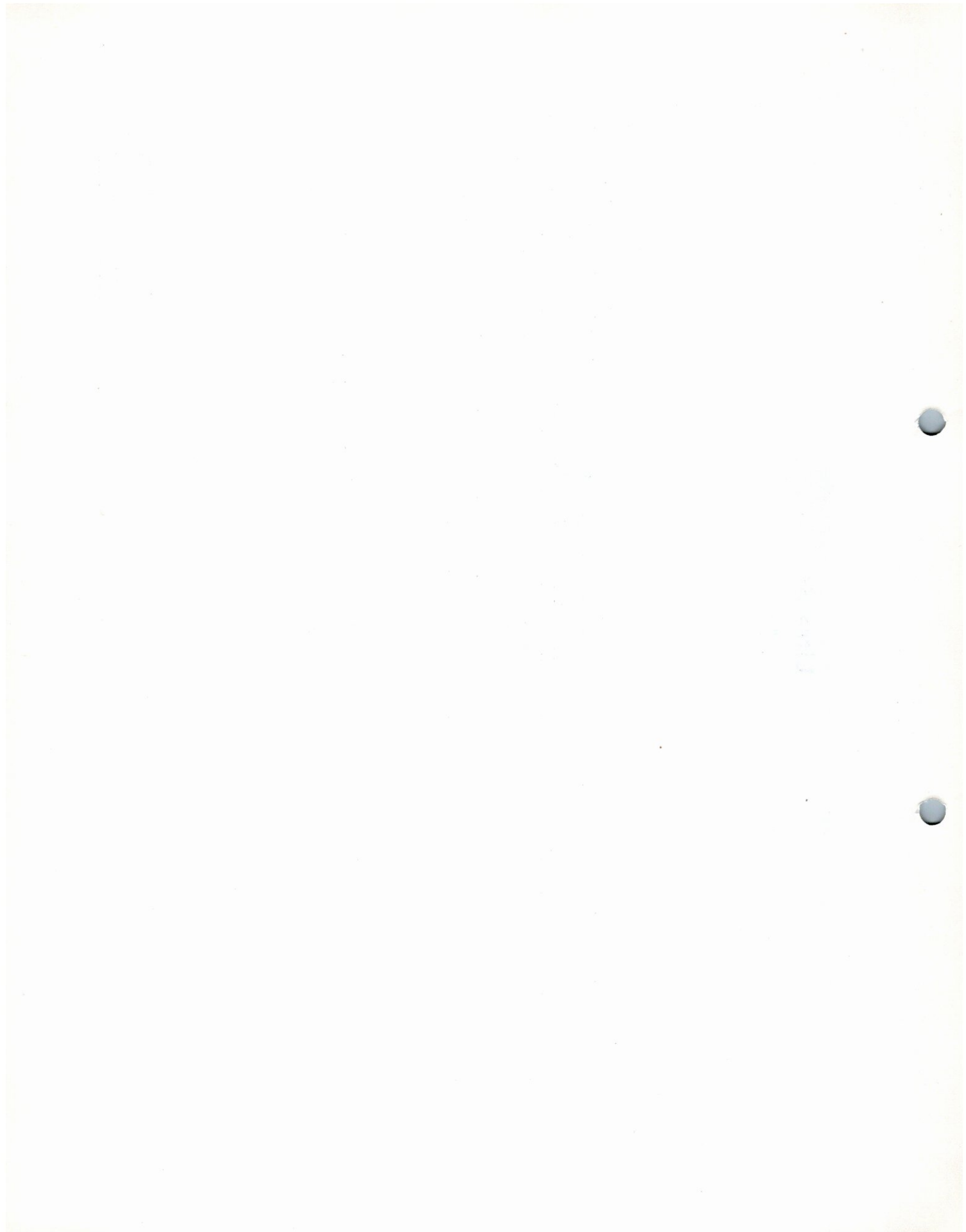

### Litra TH

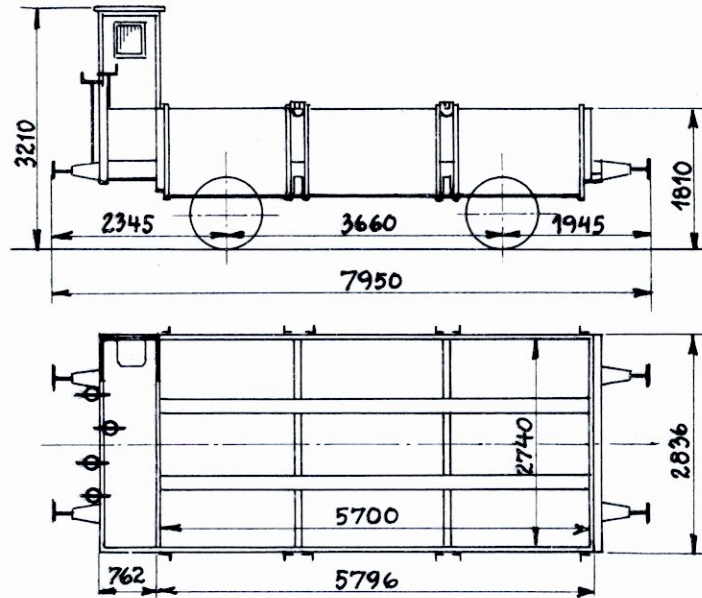

Bundflade 15,6 m<sup>2</sup>

A	B	C
16,5 t		16,5 t

### Litra TK

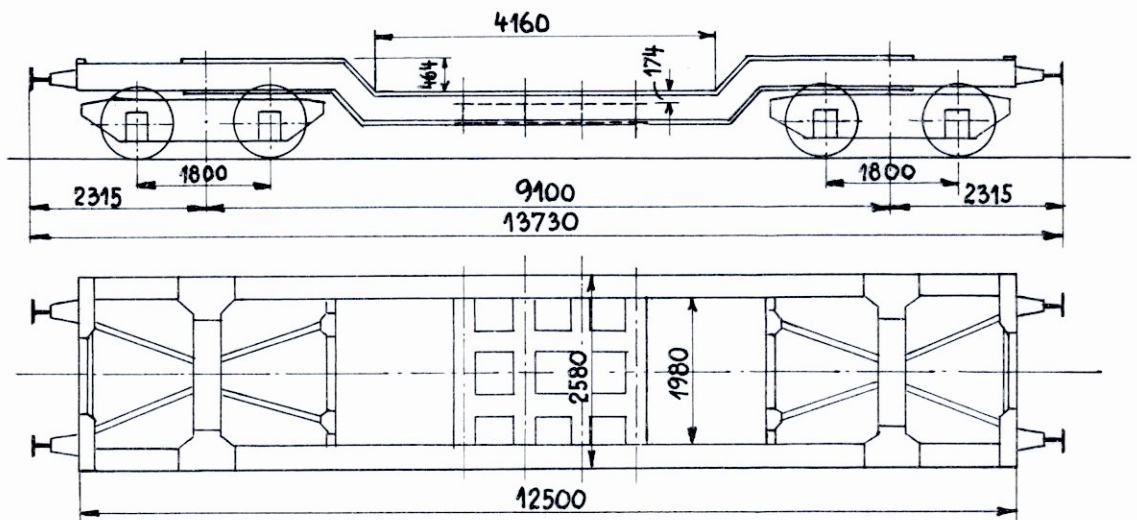

A	B	C
40,5 t		40,5 t



943 2 000 - 943 2 129

Tjenestegodsvogn

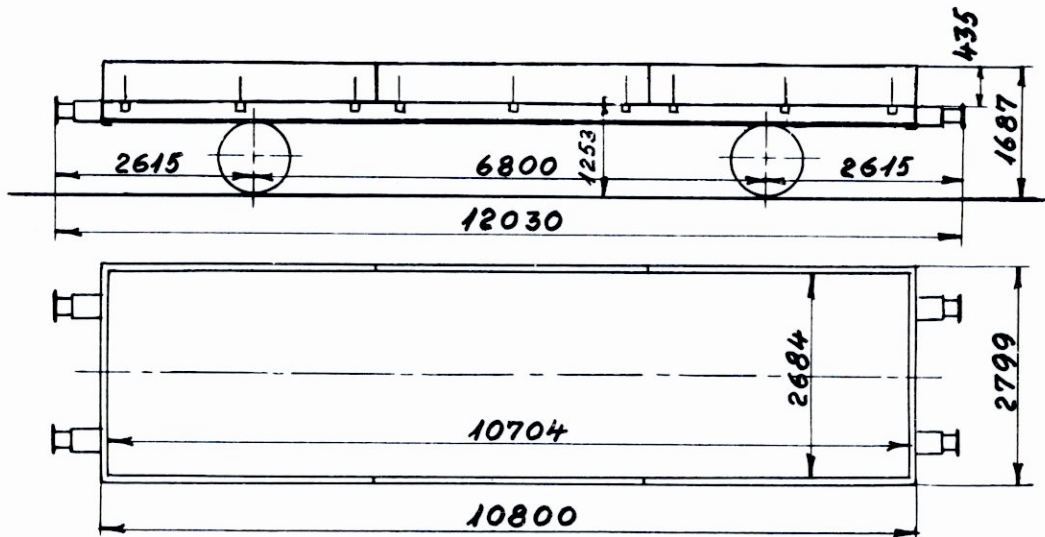

1932/50 Scandia

Ballastvogn

Bundflade 28,8 m<sup>2</sup>

A	B	C
17,5 t		

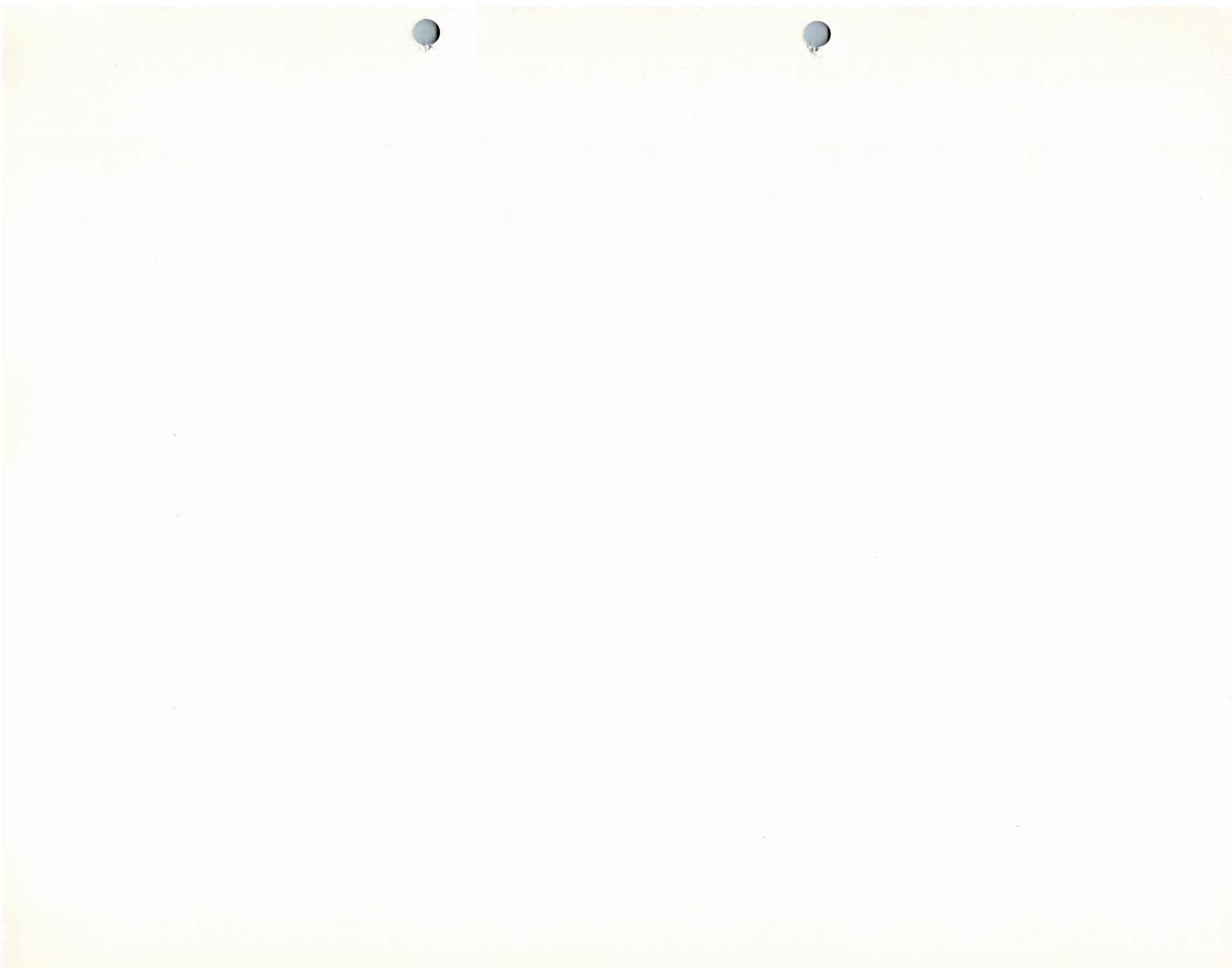

**945 0 500-945 0 501**

Tjenestegodsvogn

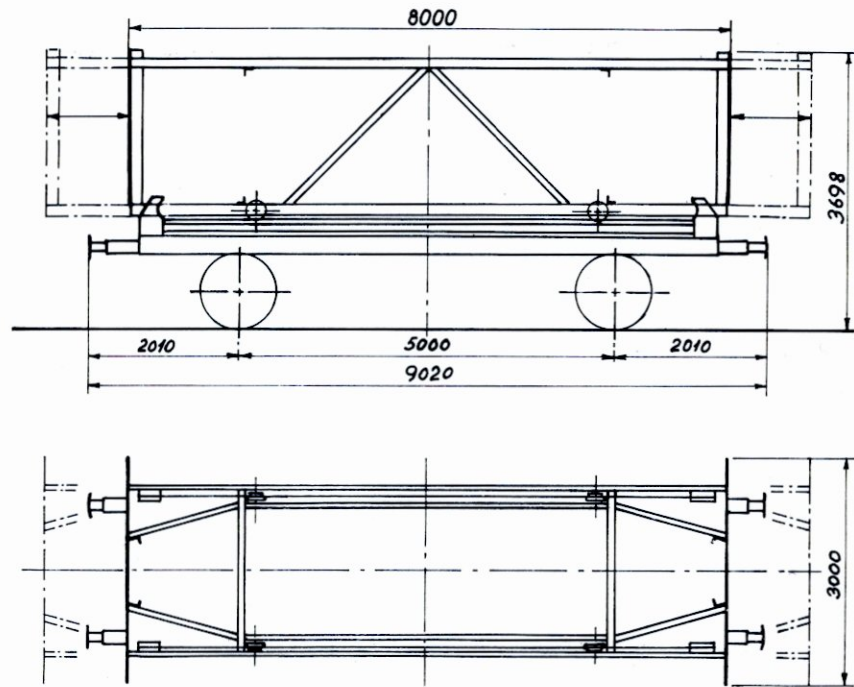

1943/50 Scandia  
Omb. 1966

Trykvogn for opretning af trælæs





### Litra U

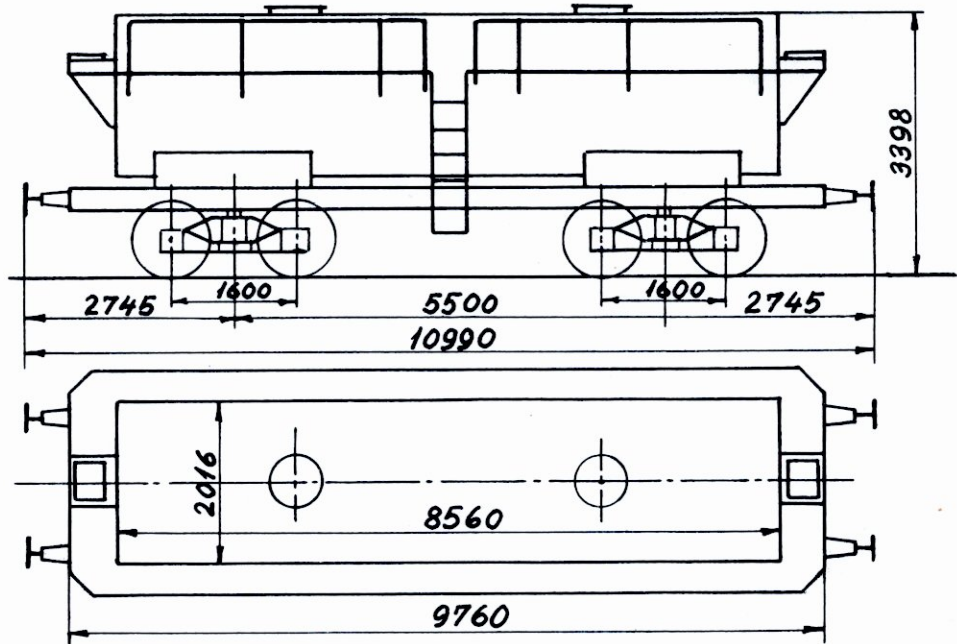

Rumindhold 26,6 m<sup>3</sup>

A	B	C
26,0 t	26,0 t	

### Litra U

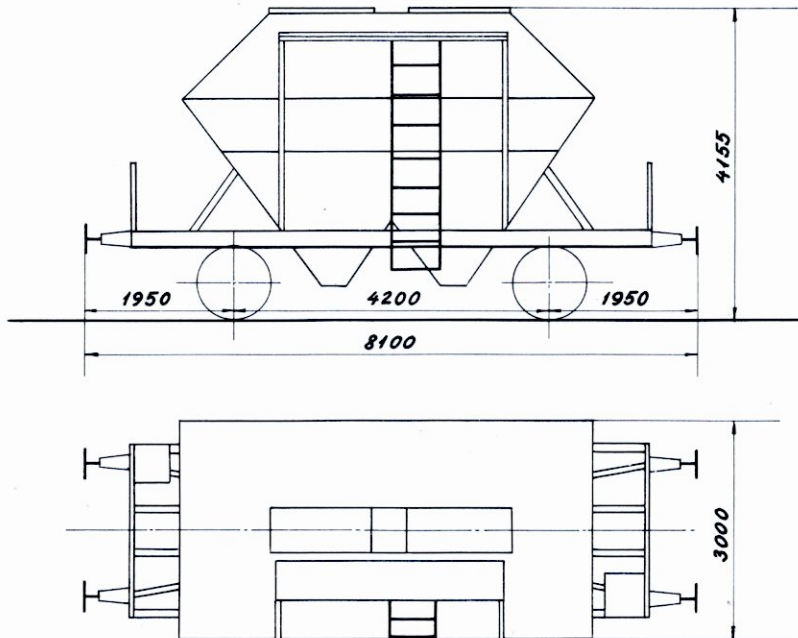

A	B	C
21,0 t	21,0 t	

Kun til transport af rå sukker

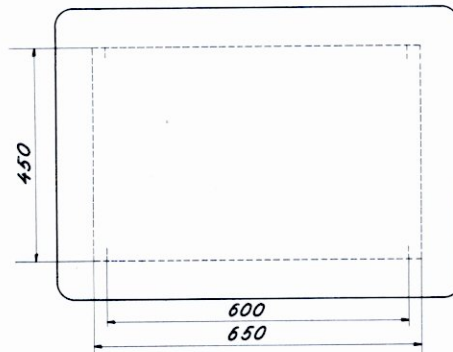
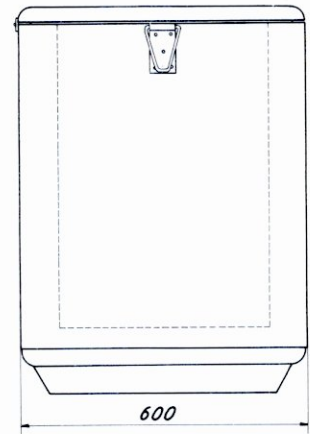
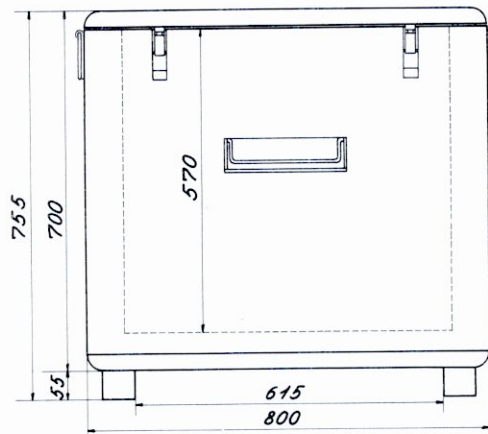

## Kølebokse

Rumindhold 0,165 m<sup>3</sup>

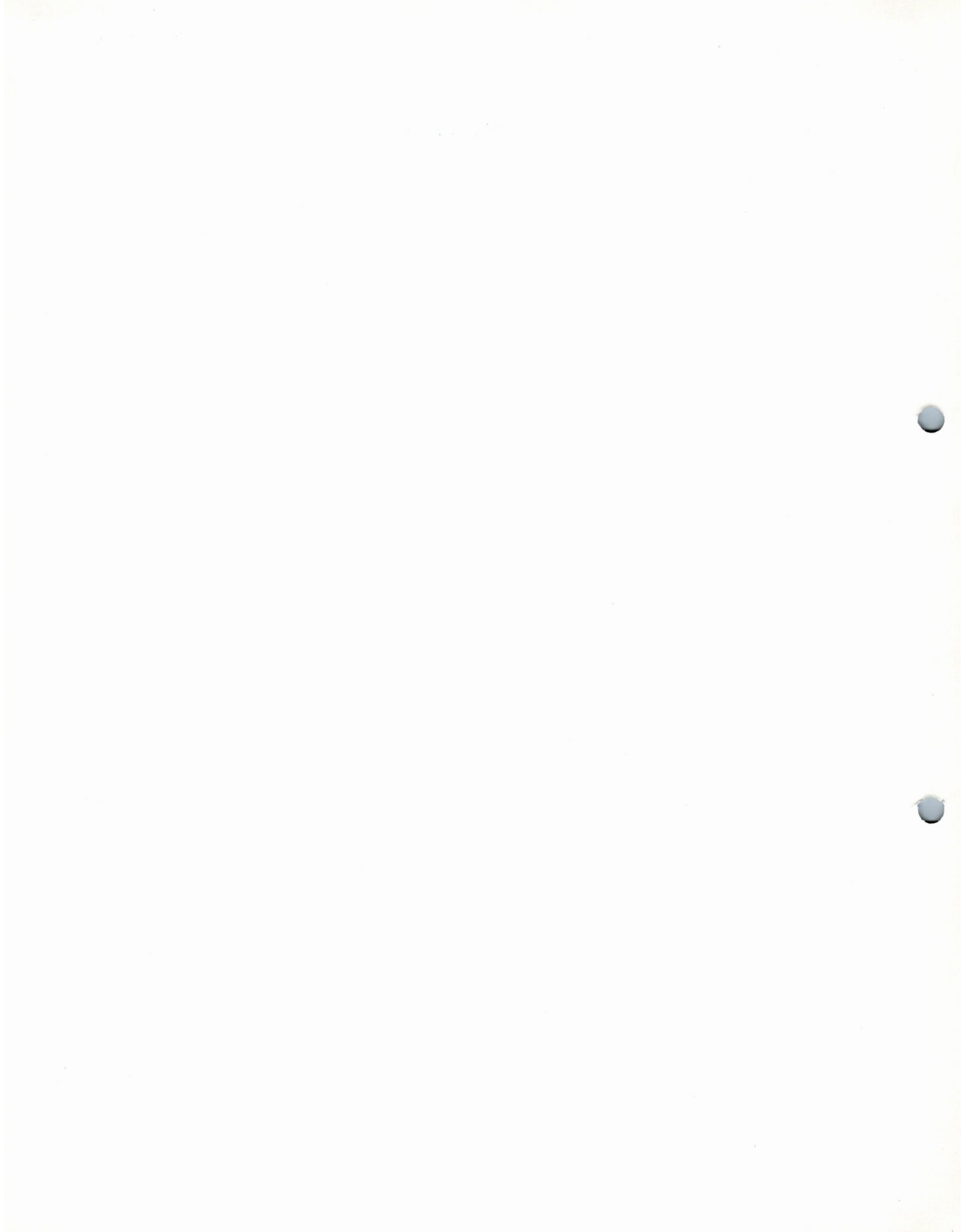

## Køletransportbeholdere Ai

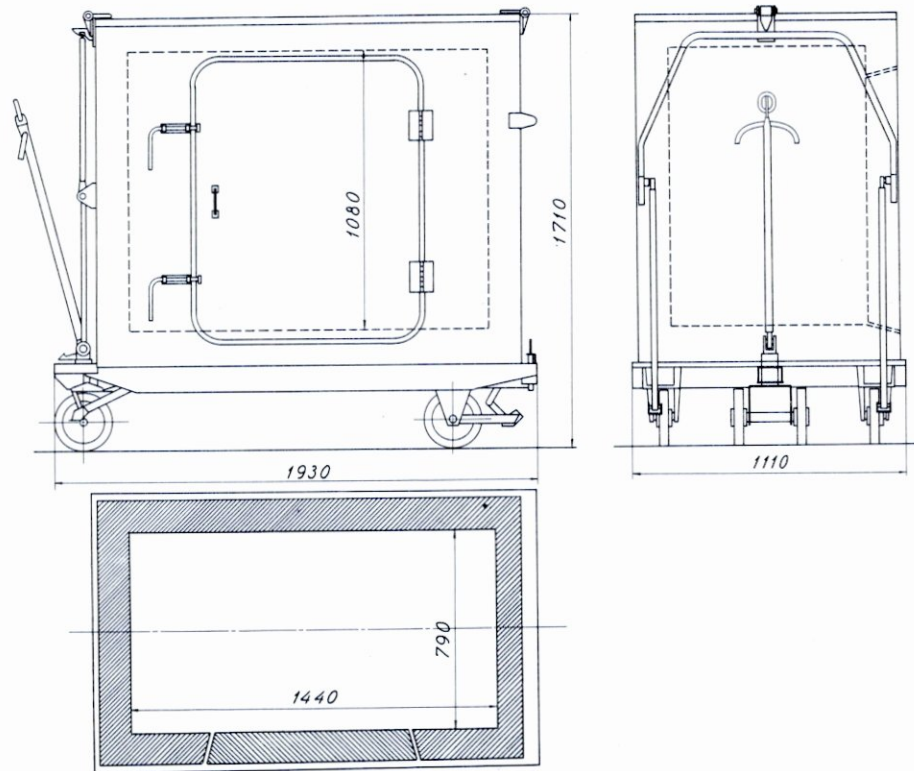
Rumindhold 1,2 m<sup>3</sup>

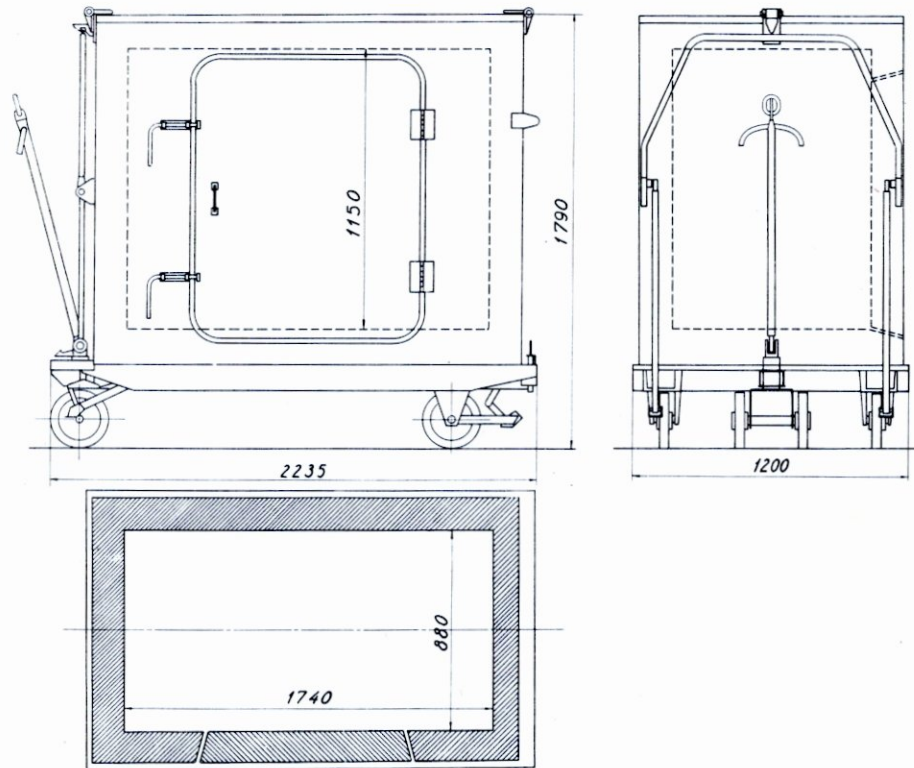

## Køletransportbeholdere B:

Rumindhold 1,7 m<sup>3</sup>

### 1950





# 100 Transportbeholdere type A

nr. 70101—70200

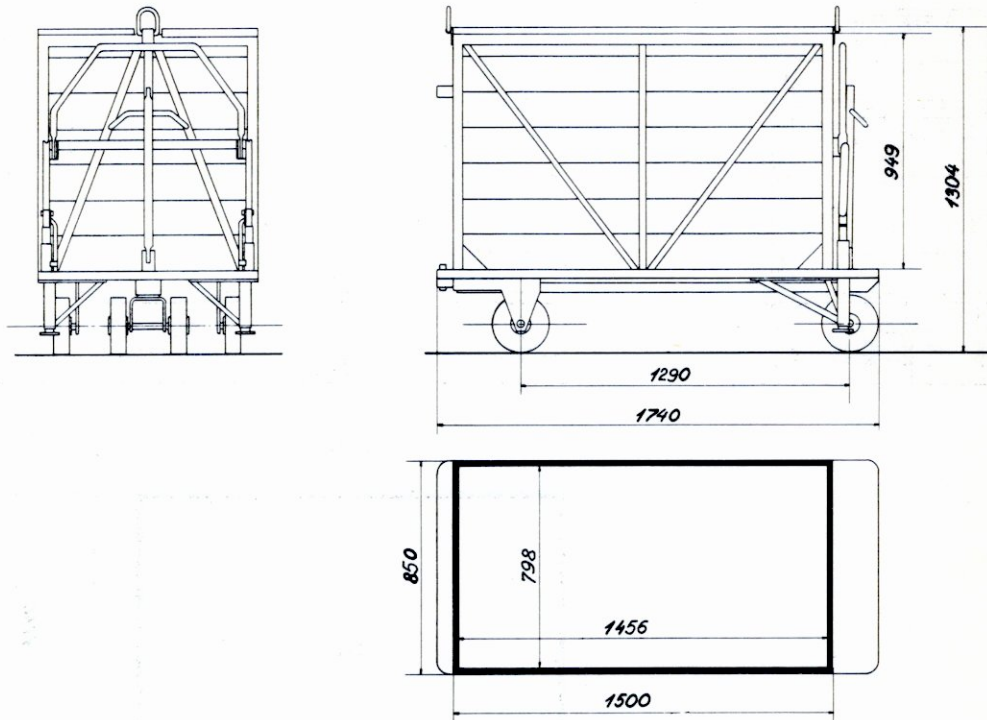

1957 Kolding

Rumindhold 1m<sup>3</sup>  
Last 1000 kg  
Tara ca. 235 kg

# 50 Transportbeholdere type C

nr. 71041—71090

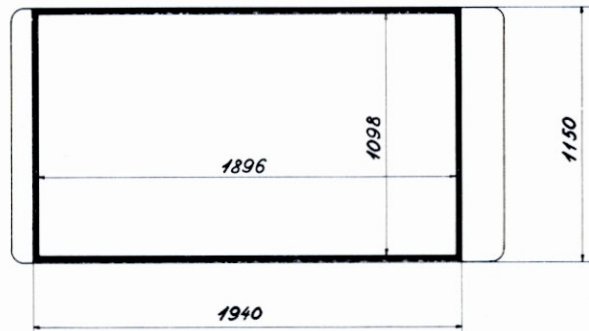
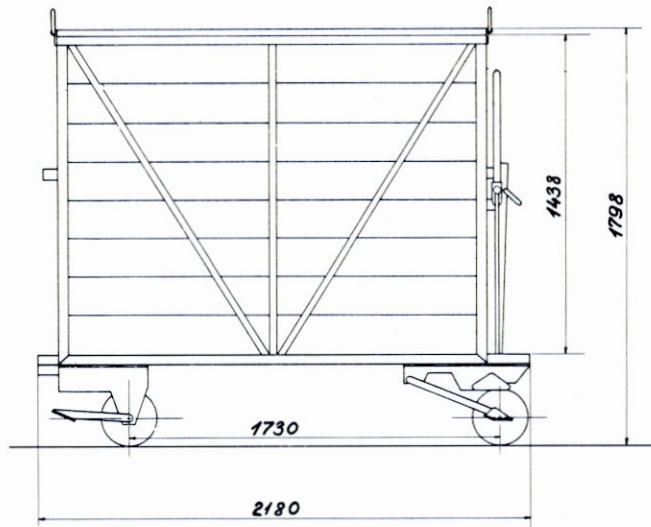
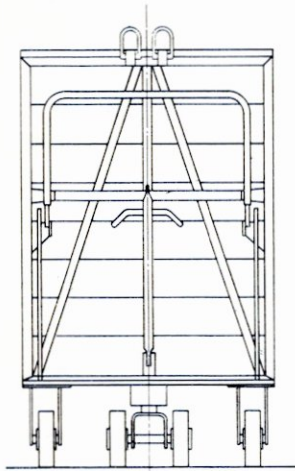

1957 A S Nielsen Holst, Århus

Rumindhold 3 m<sup>3</sup>  
Last 1000 kg  
Tara ca. 410 kg

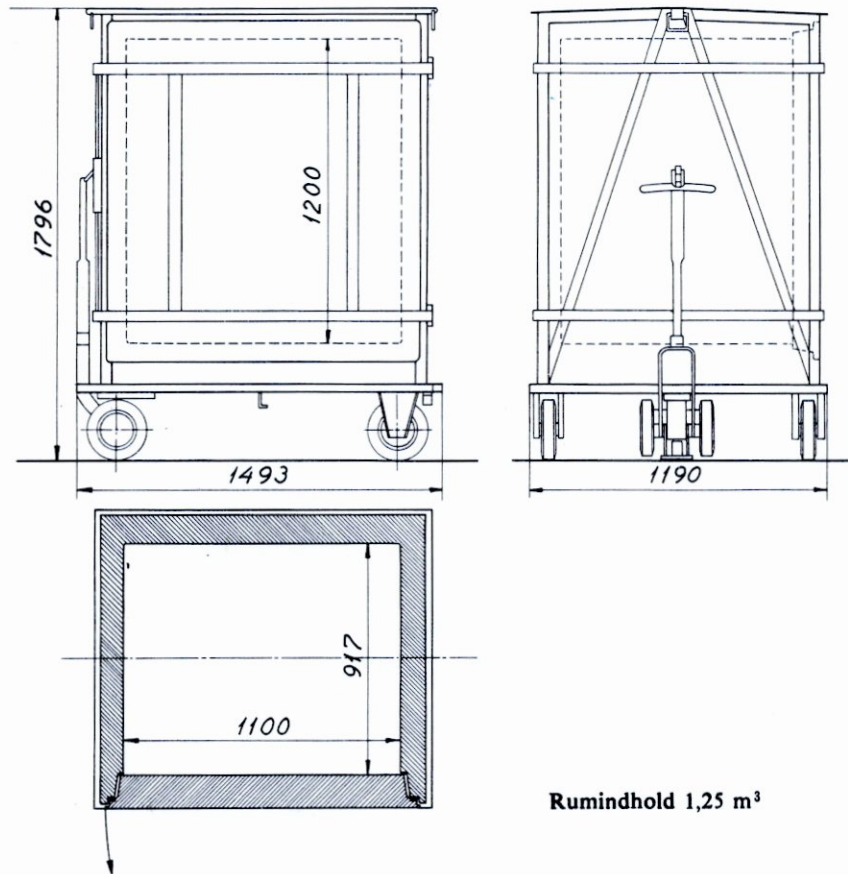
**Køletransportbeholdere Ai**

100

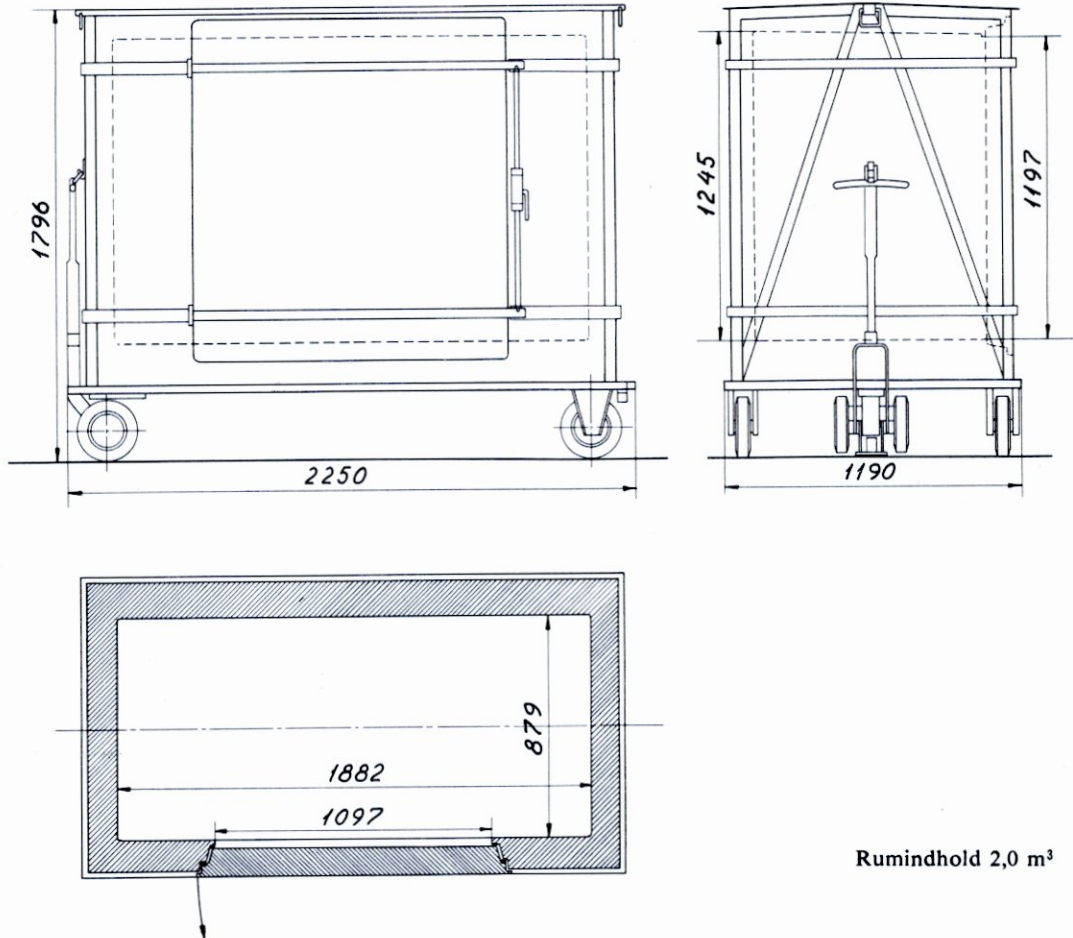

**Køletransportbeholdere B1**

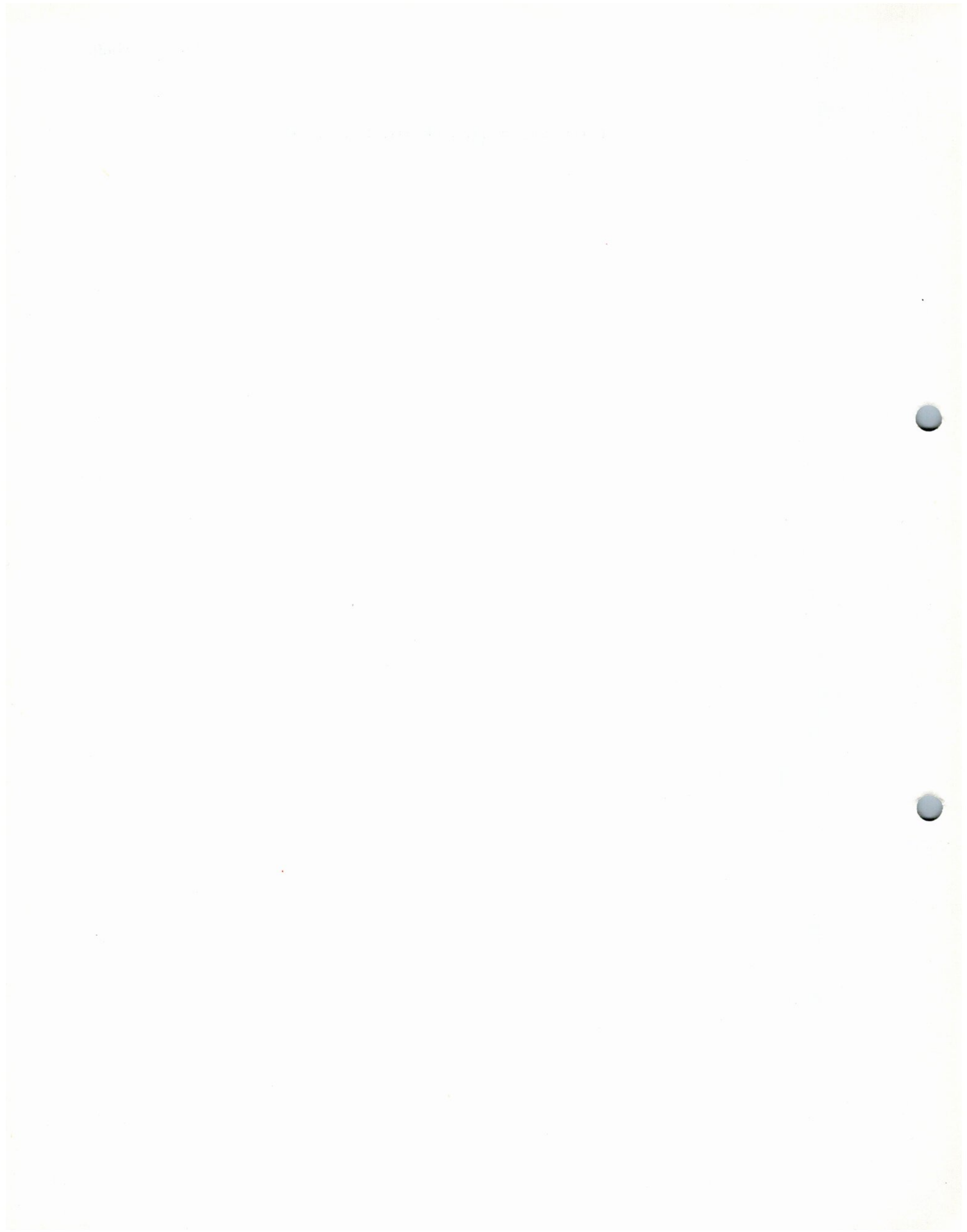

# Transportbeholdere A

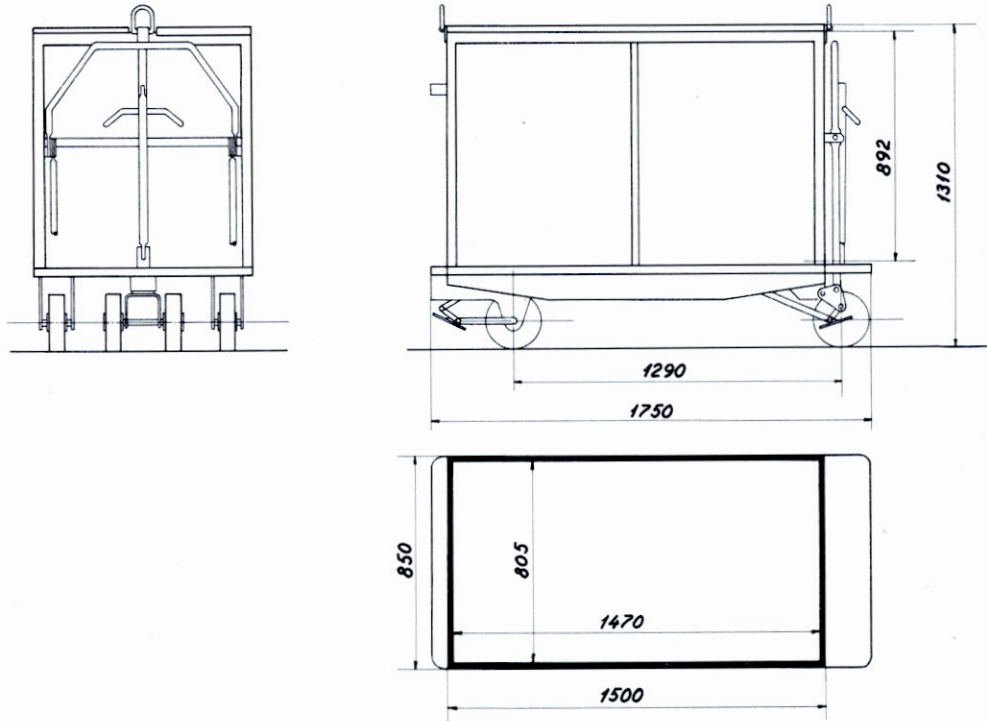

Rumindhold 1,0 m<sup>3</sup>

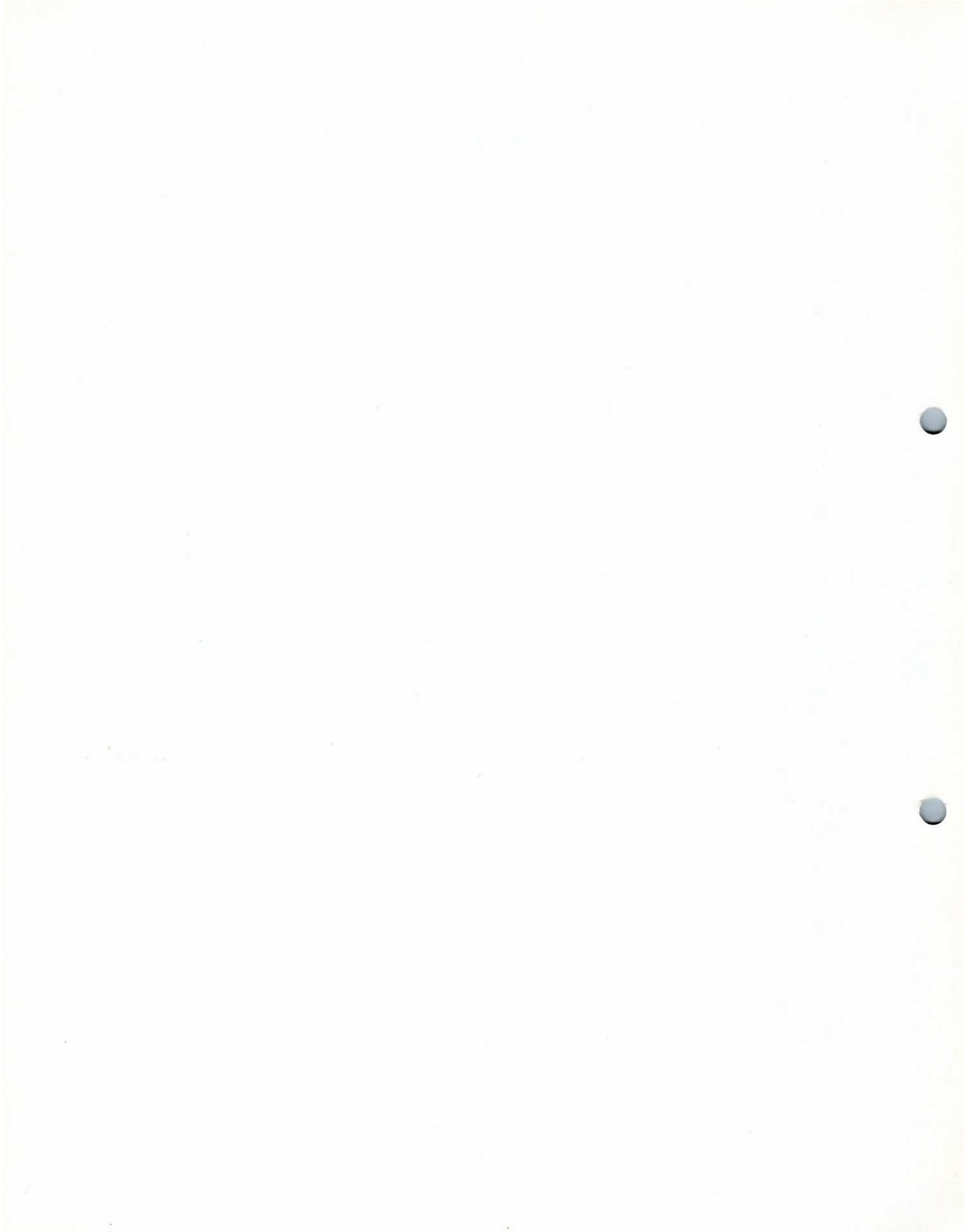

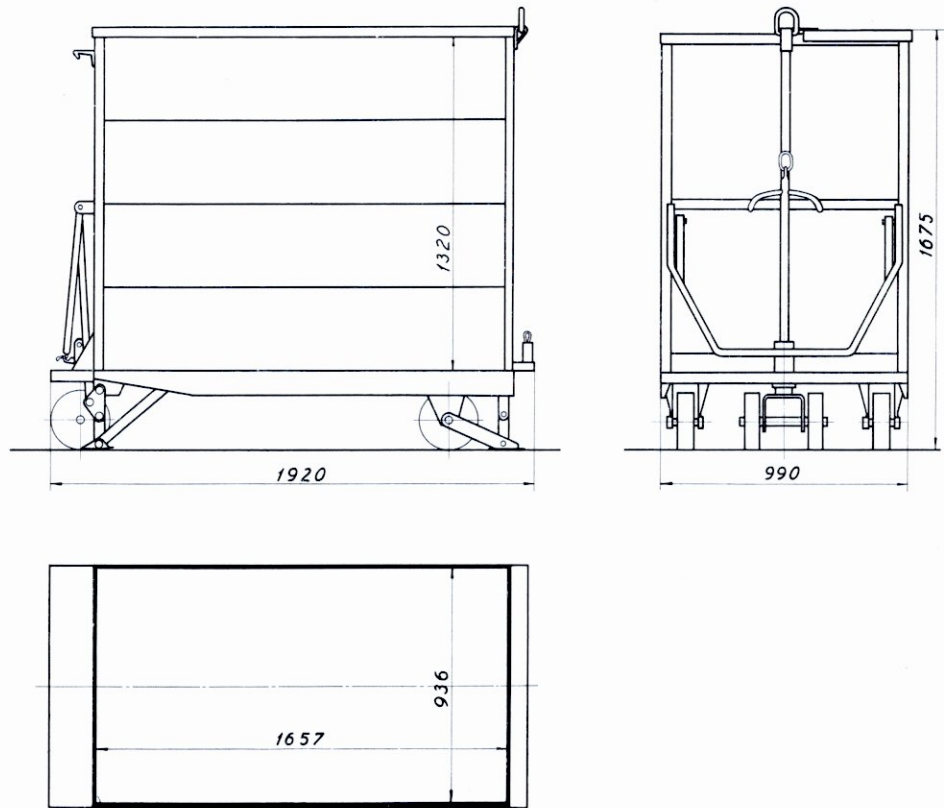

## Transportbeholdere B

Rumindhold 2 m<sup>3</sup>

1950-1951



## Transportbeholdere B

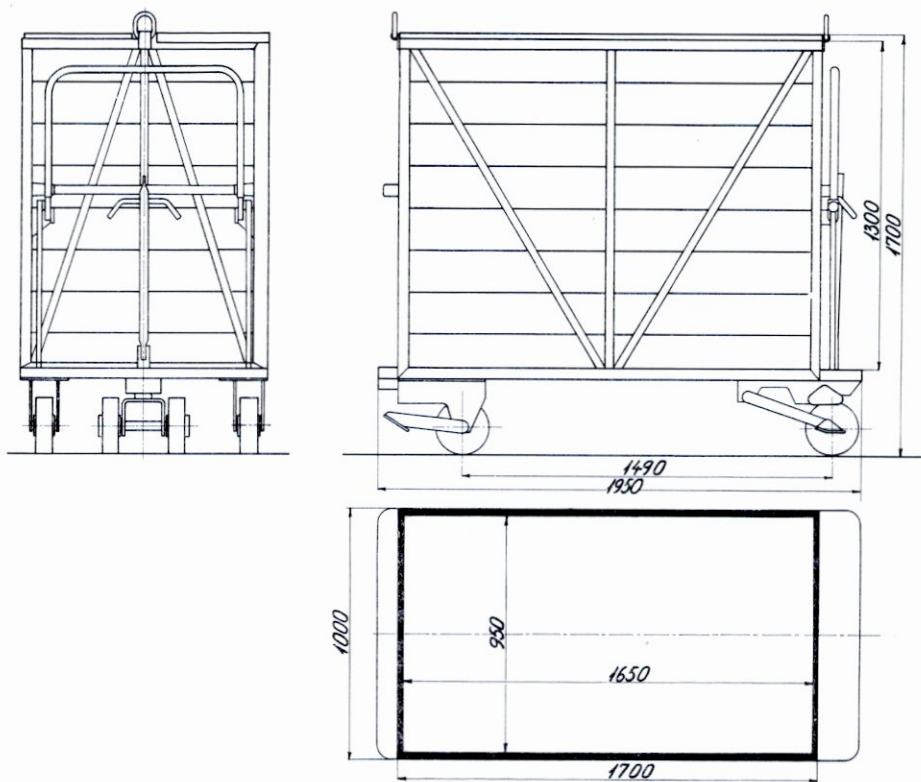

Rumindhold 2 m<sup>3</sup>



# Transportbeholdere A

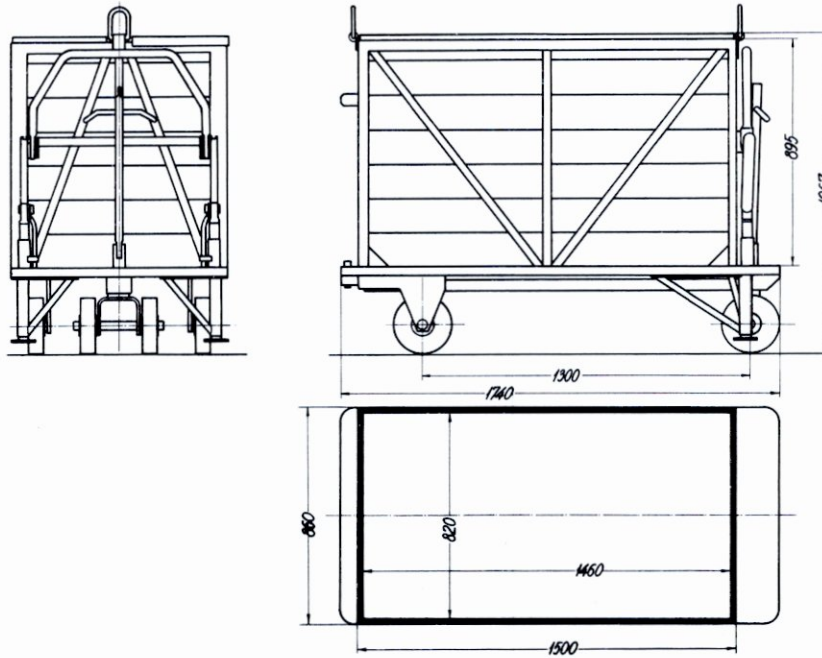

Rumindhold 1,0 m<sup>3</sup>



# Transportbeholdere A

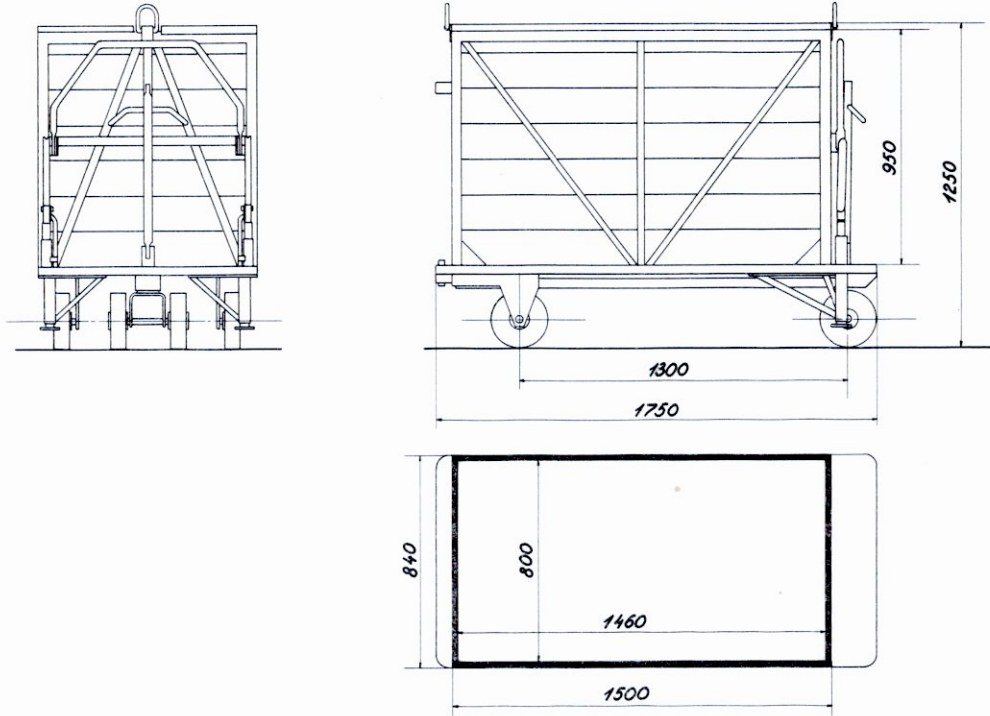

Rumindhold 1,0 m<sup>3</sup>





## Transportbeholdere B og C

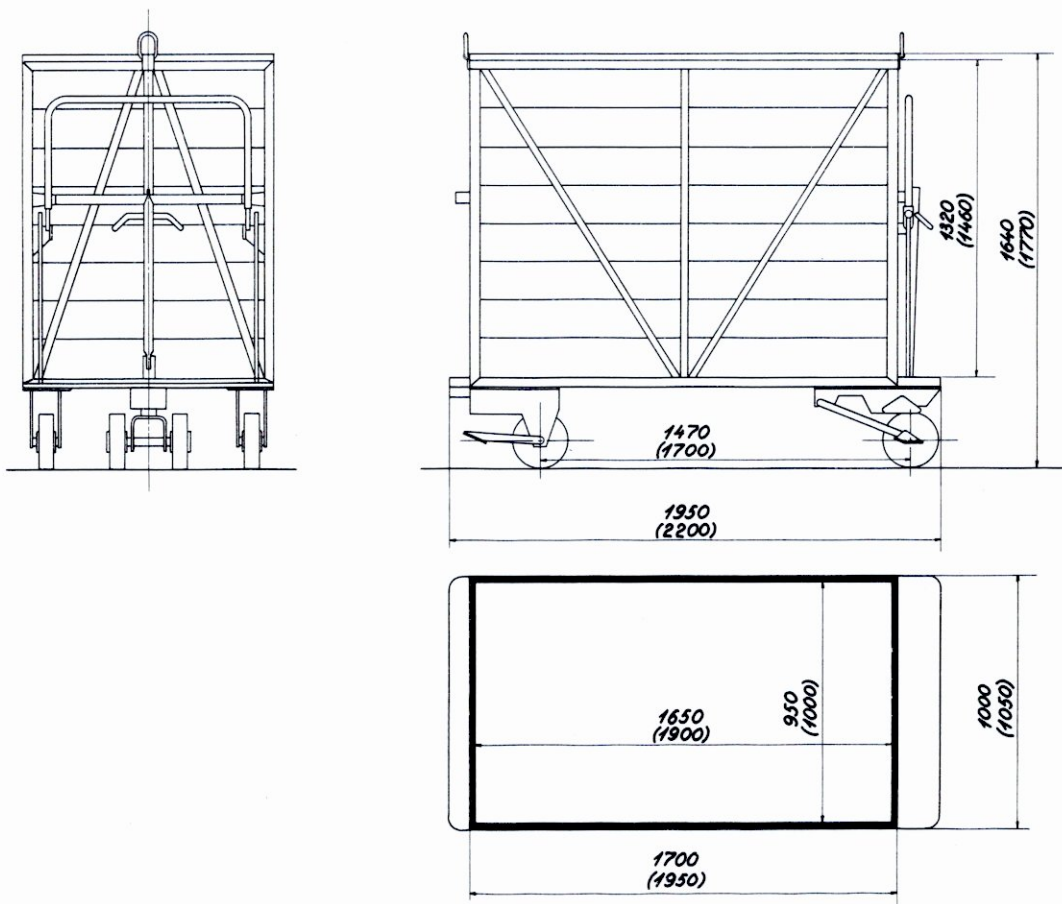

Rumindhold  $\left\{ \begin{array}{l} B = 2 \text{ m}^3 \\ C = 3 \text{ m}^3 \end{array} \right.$

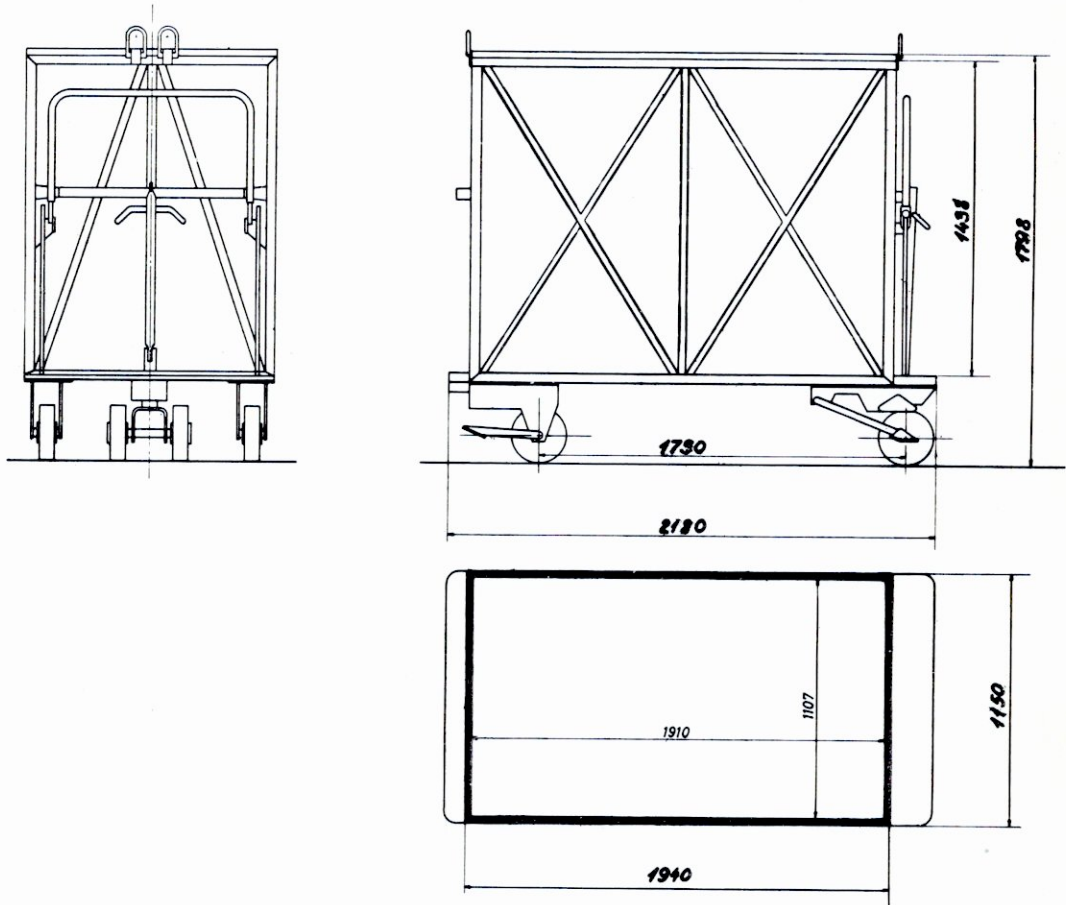

**Transportbeholdere C 75000-75050**

Byggeår 1968

Rumindhold 3 m<sup>3</sup>





DANSKE STATSBANER

---

Tillæg

til fortegnelsen over

# Driftsmateriellet II

1966

Siderne 201-I til 291-I udgår.

**Fortegnelsen består, med dette indlæg, af følgende sider:**

1-IV	32-V	76c-II	98-I	119h-I	228-I <del>II</del> x
4-IV	33-VIII	76e-I	99-I	119i-I	229-IIx
5-III	35-IV	76g-I	100-I	119j-I	230-IIx
6a-I	45-VI	76i-I	100a-I	119k-I	231-IIx
8a-I	46-IV	76m-I	101-I	119l-I	232-IIx
8c-I	47-III	76o-I	102-I	201-IIx	233-IIx
9-IV	48a-V	76r-I	103-I	203-IIx	234-IIx
9a-I	48d-VII	76t-I	104-I	204-IIx	235-IIx
9b-I	48e-II	78c-I	105-I	205-IIx	236-IIx
10a-IX	48f-II	78d-I	106-I	206-IIx	237-IIx
10b-IX	50-III	78e-I	107-I	207-IIx	238-IIx
10c-VIII	52-IV	78f-I	108-I	208-IIx	239-IIx
10d-VIII	54-III	78g-I	108a-I	209-IIx	240-IIx
10e-II	55-VI	78i-I	109-I	210-IIx	241-IIx
10f-II	56-VI	79-V	110-I	211-IIx	242-IIx
10g-III	57-IV	80-IV	111-I	212-IIx	243-IIx
11-III	58-IV	80a-II	112-I	213-IIx	244-IIx
15-IV	59-IV	80b-II	113-I	214-IIx	245-IIx
15b-I	60-IV	80c-II	114-I	215-IIx	
25-III	61-III	80d-II	115-I	216-IIx	
25b-I	62-III	80e-II	116-I	217-IIx	
26-II	63-IV	85-I	117-I	218-IIx	
26a-I	64a-I	87-I	118-I	219-IIx	
27-III	65-III	88-I	119-I	220-IIx	
27d-I	66-III	89-I	119a-I	221-I <del>II</del> x	
27e-I	67-III	90-I	119b-I	222-IIx	
28-III	68-III	91-I	119c-I	223-IIx	
28a-I	73-III	92-I	119d-I	224-IIx	
28b-I	75-II	92a-I	119e-I	225-IIx	
28c-I	76-II	93-I	119f-I	226-IIx	
30-IV	76a-II	94-I	119g-I	227-IIx	

Med dette tillæg følger siderne, der i ovenstående fortegnelse er mærket med x; ialt 23 blade.

## Skematisk fortegnelse

over

# PRIVATE VOGNE

der er optaget i Statsbanernes vognpark

I forbindelse med det sydlige udland må en privat godsvogn kun benyttes, når den er forsynet med det internationale mærke RIV.

De i fortegnelsens rubrik »lastgrænse«, »bremse« og »varme« anvendte forkortelser er:

- A** = lastgrænse 16 t akseltryk
- B** = » 18 t »
- C** = » 20 t »
- L** = varmeledning
- S** = skruebremse
- P** = nødbremseindretning
- RS** = rangerskruebremse
- S** = skruebremse
- TB** = trykluftbremse
- TL** = trykluftledning

18

PRIVACY







DANSKE STATSBANER

---

Tillæg

til fortegnelsen over

# Driftsmateriellet II

1967

**Med dette tillæg følger siderne:**

100a—II

100b—I

100c—I

100d—I

105—II

106—II

108a—II

108b—II







DANSKE STATSBANER

---

Tillæg

til fortegnelsen over

# Driftsmateriellet II

1967

2. udgave

Siderne 119-I til 119k-I udgår.

Fortegnelsen består, med dette tillæg, af følgende sider:

1-IV	28a-I	76c-II	98-I	181-Ix	221-II
3a-Ix	28b-I	76e-I	99-I	182-Ix	222-II
3b-Ix	28c-I	76g-I	100-I	183-Ix	223-II
3c-Ix	36-IIIx	76i-I	100a-II	184-Ix	224-II
4-Vx	40-IVx	76k-IIx	100b-I	185-Ix	225-II
5-IVx	41-IIx	76o-I	100c-I	186-Ix	226-II
6a-IIx	42-IIx	76r-I	100d-I	187-Ix	227-II
7-Vx	45-VI	76t-I	101-IIx	188-Ix	228-II
8a-IIx	46-IV	78c-I	102-IIx	189-Ix	229-II
8c-IIx	47-III	78d-I	103-I	201-II	230-II
9-VIIx	48a-V	78e-I	104-I	203-II	231-II
9a-I	48d-VII	78f-I	105-II	204-II	232-II
9b-I	54-III	78g-I	106-II	205-II	233-II
10a-IX	55-VI	78i-I	107-I	206-II	234-II
10b-IX	56-VI	79-V	108-I	207-II	235-II
10d-VIII	60-IV	80-IV	108a-II	208-II	236-II
10e-II	61-III	80a-II	108b-II	209-II	237-II
10f-II	62-III	80b-II	108c-Ix	210-II	238-II
10g-III	63-IV	85-I	108d-Ix	211-II	239-II
11-III	64a-I	87-I	109-I	212-II	240-II
15-IV	65-III	88-I	110-I	213-II	241-II
25-III	66-III	89-IIx	111-I	214-II	242-II
25b-I	67-III	90-IIx	112-I	215-II	243-II
26-II	68-III	91-I	113-I	216-II	244-II
26a-I	73-III	92-I	115-I	217-II	245-II
27-III	75-II	92a-I	116-I	218-II	
27d-I	76-II	93-I	117-I	219-II	
28-III	76a-II	94-I	118-I	220-II	

Med dette tillæg følger siderne, der i ovenstående fortegnelse, er mærket med x; i alt 23 blade.

Specialv. nr.	Anvendelse	Bygge- år	Fabrikations- sted	Ombygget		Længde o. puff. mm	Aksel- afstand mm	Vogn- vægt t	Bremse	Lys Varme	Hjem- sted	Vk omr.	
				Vk	år								
6-47	Sneplov												
48-71	"												
72-74	"												
98-99	"												
101-109	"												
1-12	Hjælpevogn												
101-104	"												
141-142	Kørekran												
143	"												
144	"												
145-146	"												
151-153	Skinneudlægningskran												
154	"												
155	"												
156-157	"												
160	Bedriftsværnsvogn	1898	Görlitz	Kh	1964	8800	4000	20	RS		Gb	Kh	1)
161	Betonsprøjtevogn	1905	Scandia	"	1948	9800	5000	14	TL "	0	Ar	Ar	
165	Brovogn	1876	Breslau	"	1951	7700	3660				Gb	Kh	1)
166	"	"	"	"	1955	"	"				"	"	1)
171	Brovægtsprøvevogn	1883	Borsig	Ng	1937	5800	3000	8	TL RS		Ng	Ng	
172	"	1884	Hartmann	"	1933	"	"	20	" "		"	"	
173	"	1882	Borsig	"	1937	"	"	28	" "		"	"	
174	"	1884	Hartmann	"	1933	"	"	10	" "		"	"	
175	"	"	Borsig	"	"	"	"	18	" "		"	"	
176	"	1901	Breda	"	1937	"	"	28	" "		"	"	
256	Bygningsvogn	1929	Scandia	Ar	1964	13700	8200	16	RS	0	Oj	Ar	
258	"	"	"	"	1963	"	"		"		Md	Ng	
259	"	"	Atlas	"	1949	7330	3960	12	H		Vj	Ar	
260	Værkstedsvogn	1929	Scandia	"	1964	13700	8200	16	TL RS	0	Ar	"	
262	Bygningsvogn	1906	"	"	1955	10700	5700		H	"	"	"	
263	"	1882	Breslau	"	1926	9000	4200		TL "		Rd	"	
268	"	1898	Scandia	"	1937	9870	4700		" S		Ab	"	
272	"	1922	"	Kh	1962	13550	8500	15	TL RS	El-stik 0	Van	Kh	

1) Må ikke befordres i tog.

Specialv. nr.	Anvendelse	Bygge- år	Fabrikations- sted	Ombygget		Længde o. puff. mm	Aksel- afstand mm	Vogn- vægt t	Bremse	Lys Varme	Hjem- sted	Vk omr.
				Vk	år							
273	Bygningsvogn	1876	Randers	Ar	1932	7700	3660		TL S		Rq	Ar
275	"	1929	Scandia	"	1963	13700	8200	16	RS	0	Sdb	"
278	"	1875	Wagenbau	"	1933	7700	3660		TL H			Ng
280	"	1923	Scandia	Kh	1961	13070	8000	15	" RS	El-stik 0	Næ	Kh
281	"	1924	"	"	1963	"	"	"	" "	" "	Hk	"
283	"	1915	"	"	1961	"	"	"	" "	" "	Kj	"
286	"	1929	"	Ar	1963	"	8200	16	" "	" "	Sj	Ar
288	"	1917	Breslau	"	1953	9580	4570		H		Ar	"
289	"	1924	Scandia	Kh	1956	13070	8000	15	TL RS	El-stik "	Gb	Kh
291	"	1906	"	Kh	1954	10700	5700	"	" "	0	Hk	Kh
293	"	1924	Scandia	Ar	1958	14400	9000	17	" RS	El-stik "	Vg	Ar
295	"	1921	"	"	"	"	"	15	" H	"	Ab	"
296	"	1922	"	Kh	1948	12210	6300	"	" S	"	Van	Kh
297	"	"	"	"	1949	"	"	13	" "	"	Rg	"
298	"	"	"	"	1922	"	"	12	" "	"	Nf	"
300	"	1907	"	"	1949	11730	"	"	" RS	"	Sg	"
301	"	1921	"	"	1960	14820	9000	15	" "	El-stik "	Hi	"
302	"	"	"	"	1961	"	"	"	" "	"	Hg	"
304	"	1882	SFJ	Ar	1950	"	8770	12	" H	"	Aæt	Ar
307	"	1886	Skabo	Ar	1955	10600	5000	12	TL H	El-stik 0	Rj	Ar
308	"	1924	Scandia	"	1959	14400	9000	16	" RS	" "	Hr	"
309	"	"	"	"	"	"	"	"	" "	" "	S1	"
310	"	1923	"	Kh	"	13070	8000	15	" "	" "	Gb	Kh
312	"	"	"	"	1963	"	"	"	" "	" "	Ro	"
313	"	1888	"	Ng	1947	10490	5000	"	" H	"	Od	Ng
314	"	1930	"	Ar	1966	9040	5000	14	" "	El-stik 0	Hj	Ar
315	"	1927	"	"	"	"	"	"	" "	" "	Rå	"
355	Elektrikere, værkstedsvogn	1886	Skabo	Ar	1955	10600	5000		TL H	0	Ar	Ar
356	"	1924	Scandia	Kh	1956	13070	8000	15	" RS	El-stik "	Kh	Kh
357	"	"	"	"	"	"	"	"	" "	" "	"	"



Specialv. nr.	Anvendelse	Bygge- år	Fabrikations- sted	Ombygget		Længde o. puff. mm	Aksel- afstand mm	Vogn- vægt t	Bremse	Lys Varme	Hjem- sted	Vk omr.
				Vk	år							
361	Hjulsættransportvogn	1922	Scandia	Ar	1966	8100	4200		TL RS		Ar	Ar
362	"	1923	"	"	"	"	"		" "		"	"
365	Færgevogn	1920	Breslau	Kh	1953	8800	4000		TB RS		Gy	Ar
366	"	"	"	"	"	"	"		" "		"	"
367	"	"	"	"	"	"	"		" "		"	"
383	Kedelvogn	1886	Breslau			9980	4780		S			Ar
384	Kedelsmede, værkstedsvogn	1916	Scandia	Kh	1965	10040	5900	17	TL H		Kh	Kh
396	Kedelvogn	1895	"	"	1961	9490	5000	14	" "		"	Ar
397	"	1901	"	Ar	"	"	"	"	" "		"	"
401	Kedelvogn, dampgenerator	1902	Scandia	Ar	1958	9490	5000	15	TL H		Ar	Ar
402	"	1913	"	"	"	"	"	14	" "		Str	Ar
403	"	1901	"	"	1960	"	"	16	TL "		Ar	"
404	"	1914	"	Kh	1962	"	"	14	" "		Kø	Kh
405	"	1901	"	"	1963	"	"	"	S		Ro	"
406	"	1924	"	Ar	1964	"	"	"	" "		Pa	Ar
407	"	1902	"	"	"	"	"	"	" "		Rd	"
408	"	"	"	"	"	"	"	"	" "		Hr	"
413	Kurvereregulering, værkstedsvogn	1924	Scandia	Ar	1958	14400	9000	16	TL RS	El-stik	O	Ar
414	"	1928	"	"	1962	13700	8200	"	" "	"	"	"
415	"	"	"	"	"	"	"	"	" "	"	"	"
416	"	1929	"	"	1964	"	"	16	TL "	"	"	"
423	Kørekran, værkstedsvogn for	Se tegning side		103-I								
424	"	"		104-I								
425	"	"		105-II								
426	"	"		105-II								
431	Løbevogn for kørekran	Se tegning side		106-II								
432	"	"		106-II								
433	"	"		107-I								
434	Løbevogn for kørekran	Se tegning side		107-I								
435	"	"		108-I								
436	"	"		108-I								
437	"	"		109-I								
438	"	"		108a-II								
439	"	"		108a-II								

Specialv. nr.	Anvendelse	Bygge- år	Fabrikations- sted	Ombygget		Længde o. puff. mm	Aksel- afstand mm	Vogn- vægt t	Bremse	Lys Varme	Hjem- sted	Vk omr.
				Vk	år							
445	Løbevogn for skinneudlægningskran											
446	"											
447	"											
455	Maskinarb. værkstedsvogn	1916	Scandia	Kh	1964	10040	5900	17	TL H	El-stik 0	Kh	Kh
459	"	"	"	"	1963	"	"	"	" "	" "	"	"
460	"	1919	"	Ar	1966	11850	7500	"	" "	"	Ar	Ar
465	Maskintjenesten, værkstedsvogn	1920	Scandia	Ar	1964	8230	4500	13	TL H		Ar	Ar
466	"	1919	"	"	1963	"	"	"	" "		"	"
467	"	1876	Randers	Kh	1955	9000	4116	12	"		Gb	Kh
470	"	1915	Scandia	"	1960	13070	8000	15	" RS		"	"
490	Opmålingsvogn	1916	"	Kh	1964	10040	5900	13	TL H		Kh	Kh
501	Signaltjenesten, værkstedsvogn	1885	Atlas	Ar	1939	10190	4874		TL RS		Es	Ar
505	"	1896	Strømmen	"	1931	"	"		" "		Ar	"
507	"	1893	Scandia	Kh	1937	"	"		" "		Hk	Kh
510	"	1906	"	Ar	1955	10700	5700		" H		Ab	Ar
513	"	1915	"	Kh	"	12990	7220		" RS		Kb	Kh
520	"	1887	Scandia	Ng	1945	10630	5200		" H		Svg	Ng
523	"	1922	"	Ar	1961	8640	4500		" RS		Ab	Ar
536	"	1881	Kockum	"	1931	10190	4874		" "		Hr	"
537	"	1885	Atlas	"	1934	"	"		" "		Ar	"
542	"	1923	Scandia	Kh	1923	13070	8000		" RS		Nf	Kh
549	"	1880	"	"	1939	10190	4874		" "		Kh	"
550	"	1885	"	"	"	"	"		" "		Ler	Kh
552	"	1896	Strømmen	"	"	"	"		TL "		Fb	Kh
554	"	1922	Scandia	"	1949	12210	6350	13	" H	El-stik 0	H1	"
555	"	1876	Randers	Ar	1944	9000	4116		" "		Vj	Ar
556	"	1886	Scandia	"	"	8480	4270		" "	0	Tdr	Ar
558	"	1907	"	Kh	1949	12220	6500		" "	El-stik "	Sg	Kh
559	"	1905	"	"	"	10700	5700	12	" "	" "	K1	"
563	"	1892	Cassel	Ar	1950	11370	7000		" RS	El-stik	Sdb	Ar
564	"	1927	Scandia	"	1962	13490	8140	16	" "	" 0	Od	Ng
566	"	"	"	"	1948	10700	5700	12	" H	" "	"	"
567	"	1882	Scandia	"	1949	8990	4270	"	" "	" "	"	"

Specialv. nr.	Anvendelse	Bygge- år	Fabrikations- sted	Ombygget		Længde o. puff. mm	Aksel- afstand mm	Vogn- vægt t	Bremse	Lys Varme	Hjem- sted	Vk omr.
				Vk	år							
568	Signal-tjenesten, værkstedsvogn	1899	Scandia	Ng	1944	10630	5200		TL H		Ng	Ng
570	"	1887	"	Ar	1947	9000	4200		" "		Oj	Ar
572	"	"	"	"	1950	9320	"	12	" "		Te	"
573	"	1898	Scandia	"	"	9870	4700	"	" "		Sk	"
575	"	1914	"	Kh	1914	13500	8000	15	" RS	El-stik 0	Rg	Kh
576	"	1913	"	"	1952	"	"	"	" "	" "	Næ	"
577	"	1924	"	"	1956	13070	"	"	" "	" "	Hg	"
578	"	"	"	"	"	"	"	"	" "	" "	Gb	"
579	"	"	"	"	1957	"	"	"	" "	" "	Ro	"
580	"	1921	"	Ar	1961	14820	9000	20	" "	" "	Es	Ar
581	"	1923	"	"	"	13070	8000	"	" "	" "	Str	Ar
582	Mandskabsvogn for kørelednings.	1897	"	Kh	"	9490	5000	14	" "	" "	Hl	Kh
583	"	1915	"	"	1962	13070	8000	15	" RS	El-stik 0	"	"
611	Signalvæsen, værkstedsvogn	1884	Breslau	Kh	1947	10880	6040		TL H	El-stik 0	Fb	Kh
612	"	"	"	"	"	"	"		" "	" "	Sg	"
613	" mandskabsvogn	1923	Scandia	"	1961	13070	8000	15	" RS	" "	Van	Kh
614	"	"	"	"	"	"	"	"	" "	" "	"	"
615	"	"	"	"	"	"	"	"	" "	" "	"	"
616	"	"	"	"	"	"	"	"	" "	" "	"	"
622	Sikringsanlægskoll. værkstedsvogn	1907	"	"	1949	11730	6300	12	" "	El-stik 0	Val	Kh
623	"	"	"	"	"	"	"	"	" "	" "	"	"
624	"	1877	Hamburg	"	1950	8630	4250	"	" H	" "	"	"
626	"	1913	Scandia	"	1953	13500	8000	15	" RS	" "	"	"
627	"	1915	"	"	1961	13070	"	"	" "	" "	Van	"
631	Skinneslibevogn	Se tegning side 110-I										
632	Skinneudlægningsvogn				1964		2500	7			Fa	Ar Bogie
633	"				1965			"			"	"
634	"				"			"			"	"
635	"	1928	Scandia	Kh	1961	13700	8200	9	TL		"	"
636	"	"	"	"	1962	"	"	"	" "		Ro	Kh
637	"	1929	B & W	"	1966	"	2400	8	" "		"	Bogie
638	"	"	"	"	"	"	"	"	" "		Fa	Ar

Specialv. nr.	Anvendelse	Bygge- år	Fabrikations- sted	Ombygget		Længde o. puff. mm	Aksel- afstand mm	Vogn- vægt t	Bremse	Lys Varme	Hjem- sted	Vk omr.
				Vk	år							
641	Slamvogn	1899	Breda	Kh	1936	5800	3000		RS		Ro	Kh
642	"	1882	Borsig	Ar	1937	"	"		"		Næ	"
643	"	1899	Breda	Kh	1940	"	"		"		Gb	"
644	"	1901	Borsig	"	1953	5720	"		TL RS		Kø	"
645	"	"	Breda	"	1954	"	"		" "		Gb	"
651	Spilvogn	Se tegning side lll-I										
652	"	" lll-I										
654	"	1943	Scandia	Kh	1966	12100	6800		TB H		Hl	Kh
666	Sprøjtevogn	1908	Linden	"	1960	7920	4x1600		" RS		Ar	Ar
670	Svejsevogn	1916	Scandia	"	1964	10040	5900	16	TL "	El-stik 0	Kh	Kh
673	"	1880	"	"	1948	10900	6050		" H	" "	"	"
674	"	1915	"	Ar	1962	13070	8000	20	" "	" "	Fa	Ar
676	"	1928	"	"	1963	13700	8200	16	" RS	" "	"	"
677	"	1929	"	"	"	"	"	"	" "	" "	"	"
678	"	1921	"	"	1960	14400	9000	"	" "	" "	"	"
680	"	1915	"	Kh	1957	13070	8000		TL "	" "	Gb	Kh
682	"	1923	"	Ar	1961	"	"		" "	" "	Ar	Ar
683	"	1913	"	"	1956	13500	"		" H	" "	Fa	"
685	"	1915	"	Kh	1961	13070	"		" RS	El-stik 0	Kh	Kh
686	"	1914	"	"	1953	13500	"		" "	" "	"	"
687	"	1923	"	Ar	1957	"	"		" H	" "	Ar	Ar
688	"	1914	"	"	"	"	"		" "	" "	Fa	"
689	"	1913	"	"	"	"	"		" "	" "	"	"
690	"	1924	"	"	1958	14400	9000	16	" "	" "	"	"
691	"	"	"	"	1959	"	"	"	" RS	" "	"	"
692	"	1923	"	Kh	1958	13070	8000	15	" "	El-stik "	Kh	Kh
693	"	"	"	"	1959	"	"	"	" "	" "	Gb	"
694	"	1918	"	Ar	"	14400	9000	20	" "	" "	Fa	Ar
696	"	1924	"	"	1958	"	"	16	" H	" 0	"	"
697	"	"	"	"	"	"	"	"	" RS	El-stik "	"	"
698	"	1923	"	Kh	1960	13070	8000	15	" "	" "	Gb	Kh
699	"	1915	"	Ar	1955	12990	7220		" "	" "	Fa	Ar
700	"	1927	Scandia	"	1963	13490	8140		" "	" "	Ar	"
701	"	1928	"	Ar	1964	13700	8200	16	" "	0	Fa	"

Specialv. nr.	Anvendelse	Bygge- år	Fabrikations- sted	Ombygget		Længde o. puff. mm	Aksel- afstand mm	Vogn- vægt t	Bremse	Lys Varme	Hjem- sted	Vk omr.
				Vk	år							
721	Svellestoppemask.værkstedsvogn	1886	Scandia	Kh	1950	10880	6040	12	TL H	El-stik 0	Kh	Kh
722	"	1914	"	Ar	1957	13500	8000		" "	" "	Ar	Ar
723	"	"	"	"	1956	"	"		" RS	" "	"	"
724	"	1924	"	"	1958	14400	9000	16	" "	" "	"	"
725	"	1926	"	"	1962	9000	5000		" H	" "	"	"
726	"	1927	"	"	"	13490	8140		" RS	El-stik 0	"	"
727	"	1901	"	"	1963	9440	5000		" "	" "	"	"
728	"	1902	"	"	"	"	"	14	" "	El-stik	"	"
729	"	1930	"	"	1964	"	"	"	" H	" "	"	"
730	"	1928	"	"	"	13700	8200	16	" RS	" "	"	"
731	Tårnvogn	Se tegning side 112-I										
733	"	" 113-I										
735	"	" 115-I										
736	"	" 116-I										
737	"	1923	Scandia	Kh	1966	13500	8000		TB RS		H1	Kh
738	"	"	"	"	"	"	"		" "		"	"
739	"	1943	"	"	"	9020	5000		" H		"	"
740	"	"	"	"	"	"	"		" "		"	"
741	"	1950	"	"	"	"	"		TL "		"	"
744	Telefonkolonnen,værkstedsvogn	1923	"	"	1958	13070	8000	15	" RS	El-stik 0	Fa	"
751	Transformatorvogn	Se tegning side 117-I										
756	Transformatorolievogn	" 117-I										
761	Tromlevogn	" 118-I										
762	"	" 118-I										
763	"	1950	Scandia	Kh	1966	9020	5000		TB H		H1	Kh
771	Vognopsynet,værkstedsvogn	1902	"	Ar	1962	9490	5000	14	TL RS	0	Ar	Ar
774	"	1911	"	Kh	1955	10630	5200	15	TB "	"	Kø	Kh
775	"	1926	"	"	"	"	"	"	" "	"	Gb	"
776	"	1919	"	Ng	1967	8640	4500		" "	"	Ro	"
778	"	1917	"	Kh	1956	10630	5200	15	" "	0	Ge	"
780	"	1911	"	Ar	1960	"	"	14	TL H	"	Hr	Ar
781	"	1917	"	"	1961	"	"	12	" "	"	Pa	"
796	Vægtsmede, værkstedsvogn	1923	"	"	1960	13070	8000	16	" RS	El-stik	Ng	Ng
797	"	"	"	"	1961	"	"	20	" "	"	"	"
798	"	"	"	"	"	"	"	"	" "	"	"	"

Specialv. nr.	Anvendelse	Bygge- år	Fabrikations- sted	Ombygget		Længde o. puff. mm	Aksel- afstand mm	Vogn- vægt t	Bremse	Lys Varme	Hjem- sted	Vk omr.
				Vk	år							
801	Transport af boreværktøj	1923	Scandia	Kh	1960	13070	8000	15	TL RS	Gas	Kk	Kh
802	" "	"	"	"	"	"	"	"	" "	"	Ar	Ar
855	Affaldsvogn	1950	"	"	1966	9020	5000		TB H		Hl	Kh
861	Transport af bogier	1930	"	Ar	1967	19420	2,5+13,2				Ar	Ar
862	" "	1931	Odense	"	"	"	"				"	"
863	" "	1929	Scandia	"	"	"	"				"	"
864	" "	"	"	"	"	"	"				"	"
901	Transport af bremsesåler	1922	"	"	1965	8100	4200	15	TL "		Av	Kh
902	" "	1921	"	"	"	"	"	"	" "		"	"
903	" "	1922	"	"	"	"	"	"	" "		"	"
904	" "	1920	"	"	"	"	"	"	" "		"	"
905	" "	1921	"	"	"	"	"	"	" "		"	"
906	" "	1922	"	"	"	"	"	"	" "		"	"
907	" "	1920	"	"	"	"	"	"	" "		"	"
908	" "	1922	"	"	"	"	"	"	" "		"	"
909	" "	1923	"	"	"	"	"	"	" "		"	"
910	" "	1920	"	"	1966	"	"	"	" "		Cvk	Kh
911	" "	1921	"	"	"	"	"	"	" "		"	"
							m					
951	Transportvogn for lange skinner	1950	Scandia	Ar	1967	9020	5,0	28			Ar	Ar
952	" "	1943	"	"	"	"	"	"			"	"

Specialv. nr.	Anvendelse	Bygge- år	Fabrikations- sted	Ombygget		Længde o. puff. mm	Aksel- afstand mm	Vogn- vægt t	Bremse	Lys Varme	Hjem- sted	Vk omr.
				Vk	år							
953	Transportvogn for lange skinner	1934	Scandia	Kh	1964	19420	2,5+13,237	TB			Fa	Ar
954	"	1931	Odense	"	"	"	"	"			"	"
955	"	1929	Scandia	"	1965	"	"	"			"	"
956	"	"	"	"	"	"	"	"			"	"
957	"	1930	"	"	"	"	"	"			"	"
958	"	1928	"	"	"	"	"	"			"	"
959	"	"	"	"	"	"	"	"			"	"
960	"	1929	"	"	"	"	"	"			"	"
961	"	1930	"	"	"	"	"	"			"	"
962	"	1929	"	"	"	"	"	"			"	"
963	"	1931	Odense	"	"	"	"	"			"	"
964	"	"	"	"	"	"	"	"			"	"
965	"	1929	Scandia	"	"	"	"	"			"	"
966	"	1931	Odense	"	"	"	"	"			"	"
967	"	"	"	"	"	"	"	"			"	"
968	"	1933	Scandia	"	"	"	"	"			"	"
969	"	1929	"	"	"	"	"	"			"	"
970	"	"	"	"	"	"	"	"			"	"
971	"	1930	"	"	1966	"	"	"			"	"
972	"	1929	"	"	"	"	"	"			"	"
973	"	"	"	"	"	"	"	"			"	"
974	"	1931	Odense	"	"	"	"	"			"	"
975	"	1928	Scandia	"	"	"	"	"			"	"
976	"	1929	"	"	"	"	"	"			"	"
977	"	1931	Odense	"	"	"	"	"			"	"
978	"	1930	"	"	"	"	"	"			"	"
979	"	1934	Scandia	"	"	"	"	"			"	"
980	"	"	"	"	"	"	"	"			"	"
981	"	1930	"	"	"	"	"	"			"	"
982	"	1931	Odense	"	"	"	"	"			"	"
983	"	1929	Scandia	"	"	"	"	"			"	"
984	"	"	"	"	"	"	"	"			"	"
985	"	"	"	"	"	"	"	"			"	"
986	"	1930	"	"	"	"	"	"			"	"
987	"	"	"	"	"	"	"	"			"	"
988	"	"	Odense	"	"	"	"	"			"	"







NORMAL-TRYKKERIET. KBH.

## International nummerering af private vogne

Regime nr.

**20**

Styrelses nr.

**86 DSB**

Vogn nr.

Kontroltal

**081 5 080 - 0** P

Hvor pladsforholdene ikke tillader den ovenfor viste anbringelse f. eks. på beholdervogne, påmales påskrifterne således:

**21 - 86 - 070 8 021 - 3** P  
**RIV DSB**

*Regime nr.:*

20: Vogne, kun til kørsel her i landet.

21: RIV mærkede vogne.

Ovenstående regime nr. gælder for vogne med fast sporvidde til normaltspor; 1435 mm.

*Styrelses nr.:*

I styrelses nr. er 1. ciffer altid større end eller lig med 2. ciffer.

EUROP-styrelserne har numrene 80–88.

80	DB	Vesttyskland
81	ÖBB	Østrig
82	CFL	Luxemburg
83	FS	Italien
84	NS	Holland
85	SBB	Schweiz
86	DSB	Danmark
87	SNCF	Frankrig
88	SNCB	Belgien

*Vognnummer:* Vognnummeret er 7-cifret

*1. ciffer* 1. ciffer er altid nul for en privat vogn.

*2. ciffer* Vogntypen kan identificeres på 2. ciffer således:

0:	Beholdervogne
1:	Lukkede vogne
2:	Lukkede vogne af speciel type
3:	Flade vogne
4:	Flade vogne af speciel type
5:	Åbne vogne
6:	Åbne vogne af speciel type
7:	Beholdervogne
8:	Køle- og afkølingsvogne
9:	Specielle vogne

<i>3. og 4. ciffer</i>	00–19:	2-akslede vogne	} kan køre i Storbritannien
	20–39:	2-akslede vogne, s-mærket	
	40–43:	3-akslede vogne	
	44–45:	3-akslede vogne, s-mærket	
	46–48:	4 enkeltaksler	
	49	4 enkeltaksler, s-mærket	
	50–69:	Bogievogn	
	70–79:	Bogievogn, s-mærket	
	80–83:	2-akslede vogne	
	84–92:	2-akslede vogne, s-mærket	
	93–94:	3-akslede vogne	
	95	4 enkeltaksler	
	96–97:	Bogievogn	
98–99:	Bogievogn, s-mærket		

*5., 6. og 7. ciffer* 5., 6. og 7. ciffer er vognens byggenummer og specielle type.

Nyt nummer	Gl. nummer	Bygningsår	Fabrikationssted	Akselafstand	Længde over puffernes stødflader	Bundflade	Lastgrænse			Omtrentlig taravægt	Bremse og varme	Hjemsted	Værkstedsområde	Anmærkning	
				mm	mm		m <sup>2</sup>	A	B						C
															t

Vognej: **A/S Vejle Kalkværk, Vejle.** Vognen er påmalet ejerens navn.

1 lukket vogn. I vognen må befordres: *Kalk.*

020 0 271	500271	1948	Scandia	6000	9260	19,6	17,5	17,5	11300	TB, S	Vj	Ar
-----------	--------	------	---------	------	------	------	------	------	-------	-------	----	----

Vognej: **Nissen & Petersen, speditører, Padborg.**

2 lukkede vogne. I vognene må befordres: *Levnedsmidler og samlegods.*

022 1 000		1965	Utrecht	8000	14200	33,0	16,0	20,0	24,0	16000	TB	Pa	Ar	RIV. S-last	A	BC	
022 1 000		"	"	"	"	"	"	"	"	"	"	"	"	»	»	»	»

Nyt nummer	Gl. nummer	Bygningsår	Fabrikationssted	Akselafstand	Længde over puffernes stødflader	Bundflade	Lastgrænse						Omtrentlig tara uden vand i kasserne	Bremse og varme	Hjemsted	Værkstedsområde	Anmærkning
							s			s							
							A	B	C	A	B	C					
				mm	mm	m <sup>2</sup>	t			t			kg				
022 0 021	500021	1955	Scandia	5700	10580	25,2	14,0	15,0	14,0	15,0	17600	TB,RS,P,L	Vj	Ar	RIV. 2-årig rev. Gasanlæg. 16 iltflasker. El-kabel 3000 v, 4 beholdere à 2200 l, 2 beholdere à 2350 l ialt 13500 l vand.		
022 0 022	500022			7000	12200	29,0	12,5	15,0	12,5	15,0	18800	" " " "	Bb	"	RIV. 2-årig rev. Gasanlæg. 16 iltflasker. El-kabel 3000 v, 4 beholdere à 3375 l, i alt 13500 l vand.		
022 0 023	500023	1953	Scandia	4850	9000	20,8	13,5	13,5	13,5	15600	" " " "	Vj	"	RIV. 2-årig rev. Brændeovn. 16 iltflasker. El-kabel 3000 v, 4 beholdere à 3000 l, ialt 12000 l vand.			
022 0 024	500024	1944	Wismar	7000	11880	26,1	15,0	15,0	15,0	16800	" " " "	"	"	RIV. 2-årig rev. Gasanlæg. 16 iltflasker. 2 beholdere à 2850 l og 4 beholdere à 1850 l, ialt 13100 l vand.			

Vognejere: **Brødrene Nissen Jøker, Vejle.** Vognene er påmalet ejerens navn.

4 fiskevogne. I vognene må beføres: *Levende fisk samt brugt emballage eller beskadiget gods, der tilbagesendes, og som hidrører fra disse forsendelser.*

Vognejer: **P. Holm Nyland, Vejle.** Vognene er påmalet ejerens navn.

1 fiskevogn. I vognen må befordres: *Levende fisk samt brugt emballage eller beskadiget gods, der tilbagesendes, og som hidrører fra disse forsendelser.*

022 0 044	500044	1953	Scandia	4850	9000	20,8	13,5	13,5	13,5	16700	TB, RS,P,L	Vj	Ar	RIV. 2-årig rev. Gasanlæg. 16 iltflasker. EL-kabel 3000 v. 4 beholdere à 3000 l, ialt 12000 l vand.
-----------	--------	------	---------	------	------	------	------	------	------	-------	------------	----	----	--

Vognejer: **N. Jøker, Esbjerg nye Havn.** Vognene er påmalet ejerens navn.

4 fiskevogne. I vognene må befordres: *Levende fisk samt brugt emballage eller beskadiget gods, der tilbagesendes, og som hidrører fra disse forsendelser.*

022 0 064	500064	1949	Scandia	6000	9260	21,3	13,5	13,5	13,0	15500	TB, RS	L	Lk	Ar	RIV. 2-årig rev. 16 iltflasker. EL-kabel 3000 v. 4 beholdere à 2950 l, ialt 11800 l vand.	
022 0 065	500065	1953	"	4850	9000	20,8	13,5	13,5	13,5	16700	"	"	P	"	"	RIV. 2-årig rev. Gasanlæg. 16 iltflasker. EL-kabel 3000 v. 4 beholdere à 3000 l, ialt 12000 l vand.
022 0 066	500066	1950	"	6000	9260	21,3	12,0	12,0	12,0	15600	"	"	"	"	"	RIV. 2-årig rev. 16 iltflasker. 4 beholdere à 3000 l, ialt 12000 l vand.
	DSB vogn IAL 19515)															
022 0 067	500067	1950	"	"	"	"	"	"	11,7	15500	"	"	"	"	"	RIV. 2-årig rev. Gasanlæg. 16 iltflasker. 4 beholdere à 2925 l ialt 11700 l vand.
	DSB vogn IAL 19536															

Nyt nummer	Gl. nummer	Bygningår	Fabrikationssted	Akselafstand	Længde over puffernes stødflader	Bundflade	Lastgrænse						Omtrentlig tara uden vand i kasserne	Bremse og varme	Hjemsted	Værkstedsområde	Anmærkning
							s			s							
							A	B	C	A	B	C					
				mm	mm	m <sup>2</sup>											

Vognejer: **Dansk Andels Ørredeskport, Brande.** Vognene er påmalet firmaets navn.

1 fiskevogn. I vognene må befordres: *Levende fisk samt brugt emballage eller beskadiget gods, der tilbagesendes, og som hidrører fra disse forsendelser.*

022 0 072	500072	1941	München	6000	9100	21,2	13,5	13,5	13,5	15800	TB,RS,P,L	Lk	Ar	RIV. 2-årig rev. 16 iltflasker. 4 beholdere à 3200 l, ialt 12800 l.
-----------	--------	------	---------	------	------	------	------	------	------	-------	-----------	----	----	--

Vognejer: **A. Bachmann, Esbjerg og E. Meyer, Sig.** Vognen er påmalet ejernes navne.

1 fiskevogn. I vognen må befordres: *Levende fisk samt brugt emballage eller beskadiget gods, der tilbagesendes, og som hidrører fra disse forsendelser.*

022 0 111	500111	1931	Leipzig	6000	11500	24,7	15,0	15,0	14,0	16500	TB,RS, L	IS	Ar	RIV. 2-årig rev. 20 iltflasker. 4 beholdere à 3000 l, ialt 12000 l vand.
-----------	--------	------	---------	------	-------	------	------	------	------	-------	----------	----	----	--

Vognejer: **J. Errboe, Silkeborg.** Vognene er påmalet ejerens navn.

2 fiskevogne. I vognene må befordres: *Levende fisk samt brugt emballage eller beskadiget gods, der tilbagesendes, og som hidrører fra disse forsendelser.*

022 0 121	500121			7000	11780	29,6	14,5	15,0	14,5	15,0	17200	TB,RS,P,L	SL	Ar	RIV. 2-årig rev. 20 iltflasker. 4 beholdere à 3375 l, ialt 13500 l vand.
022 0 122	500122	1924	Linke-Hofmann	6000	12120	25,0	13,0	"	13,0	"	19000	" " " "	"	"	RIV. 2-årig rev. Gasanlæg. 20 iltflasker. 4 beholdere à 3275 l, ialt 13100 l vand.

Vognejer: **Tykskov Dambrug, Ejstrupholm.**

1 fiskevogn. I vognen må befordres: *Levende fisk samt brugt emballage eller beskadiget gods, der tilbagesendes og som hidrører fra disse forsendelser.*

022 0 134	500134	1958	Scandia	5700	10580	25,2	15,0	16,5	15,0	16,5	16900	" " " "	Bb	"	RIV. 2-årig rev. Gasanlæg. 20 iltflasker. 4 beholdere 2400 l, 2 beholdere à 2550 l, ialt 14700 l vand.
-----------	--------	------	---------	------	-------	------	------	------	------	------	-------	---------	----	---	---

022 1 000 - 001 Se side 205 Nissen & Petersen

040 0 001 - 004 Se side 232 Dansk Svovlsyre- og Superphosphat-Fabrik



Nyt nummer	Gl. nummer	Bygningsår	Fabrikationssted	Akselafstand mm	Længde over puffernes stødflader mm	Rumindhold l	Lastgrænse			Omtrentlig taravægt kg	Bremse og varme	Hjemsted	Værkstedsområde	Anmærkning
							A	B	C					

Vognejer: **Dansk Esso A/S, København.** Vognene er påmalet ejerens navn.

121 beholdervogne. I vognene må befordres: *Benzin, petroleum, brændselolie, smørelie, sprit, asfalt og mineralsk terpentin.*

070 0 119	502119	1903	Zypen	3660	7780	12500	10,5	10,5	8500	TL,RS	Ng,Avn	Ng	
070 0 127	502127	1904	"	"	"	"	"	"	8000	" "	Ab	Ar	
070 0 148	502148	1905	"	"	"	"	"	"	"	" "	Ng,Avn	Ng	
070 0 149	502149			"	"	"	"	"	8500	" "	"	"	
070 0 155	502155	1903	Herbrand	4000	9050	15400	15,7	15,7	9200	TL,RS	"	"	
070 0 157	502157	1914	Cassel	4500	9300	18800	15,1	15,1	10300	" "	Ab	Ar	
070 0 159	502159	1909	Hannover	4000	8800	15300	15,2	15,2	10300	" "	Ng,Avn	Ng	
070 0 161	502161	1919	Bremen	4000	8800	18600	14,1	14,1	11500	" "	"	"	
070 0 162	502162	"	"	"	"	"	"	"	11300	" "	Gb,Prø	Kh	
070 0 163	502163	"	"	"	"	"	15,9	15,9	11100	" "	"	"	
070 0 164	502164	"	Wismar	"	"	19000	"	"	11200	" "	Ar	Ar	
070 0 165	502165	"	"	"	"	"	13,9	13,9	11300	" "	Ng,Avn	Ng	
070 0 166	502166	"	"	"	"	"	"	"	11500	" "	Ab	Ar	
070 0 167	502167	"	"	"	"	"	"	"	"	" "	Gb,Prø	Kh	
070 0 169	502169	"	Zwickau	"	"	17200	14,2	14,2	11200	" "	"	"	
070 0 172	502172	1905	Werdau	3900	8170	14100	17,0	17,0	8400	" "	Ng,Avn	Ng	
070 0 176	502176	1919	Wismar	4000	8780	17400	15,5	15,5	9500	" "	Gb,Prø	Kh	
070 0 177	502177	1911	Zwickau	"	"	18800	14,7	14,7	10000	" "	Ng,Avn	Ng	
070 0 178	502178	1920	Bremen	"	8800	15000	14,5	14,5	10700	" "	Gb,Prø	Kh	
070 0 179	502179	"	"	"	"	"	"	"	"	" "	Ng,Avn	Ng	
070 0 180	502180	"	"	"	"	"	"	"	10400	" "	Ab	Ar	
070 0 181	502181	"	"	"	"	"	"	"	11100	" "	Ng,Avn	Ng	
070 0 182	502182	"	"	"	"	"	"	"	11200	" "	"	"	
070 0 183	502183	"	"	"	"	"	"	"	10800	" "	"	"	
070 0 184	502184	"	"	"	"	"	"	"	10700	" "	Gb,Prø	Kh	
070 0 185	502185	"	"	"	"	"	"	"	"	" "	Næ	"	
070 0 186	502186	"	"	"	"	"	"	"	11600	" "	Ar	Ar	
070 0 187	502187	"	"	"	"	"	"	"	11200	" "	Ab	"	
070 0 188	502188	"	"	"	"	"	"	"	"	" "	Ng,Avn	Ng	
070 0 191	502191	"	"	"	"	"	"	"	11000	" "	Ab	Ar	
070 0 192	502192	"	"	"	"	"	"	"	11100	" "	Gb,Prø	Kh	

Nyt nummer	Gl. nummer	Bygningsår	Fabrikationssted	Aksel-	Længde	Rum-	Lastgrænse			Omtrentlig taravægt	Bremse og varme	Hjemsted	Værkstedsområde	Anmærkning
				afstand	over puffernes stødflader		indhold	A	B					
				mm	mm	l	t			kg				
070 0 193	502193	1901	Zypen	4200	9250	15700	15,7	15,7	9500	TL, RS	Gb,Prø	Kh		
070 0 194	502194	1902	"	4000	8850	"	"	"	"	" "	"	"		
070 0 195	502195	1907	"	4200	9100	18940	"	"	10700	" "	Ng,Avn	Ng		
070 0 196	502196	1904	Herbrand	4000	9450	14860	"	"	9500	" "	"	"		
070 0 197	502197	1906	Zypen	4200	9100	18940	"	"	10500	" "	Gb,Prø	Kh		
070 0 202	502202	1911	"	4000	8600	18000	15,4	15,4	9900	" "	Ng,Avn	Ng		
070 0 204	502204	"	"	"	"	"	"	"	10000	" "	Fn	Kh		
070 0 207	502207	"	"	"	"	"	"	"	9900	" "	Ab	Ar		
070 0 208	502208	"	"	"	"	"	"	"	10200	" "	Ng,Avn	Ng	RIV	
070 0 211	502211	1913	"	"	"	"	10,3	10,3	10700	TB, "	"	"		
070 0 212	502212	"	"	"	"	"	15,3	15,3	10300	TL, "	Fn	Kh		
070 0 213	502213	"	"	"	"	"	"	"	10600	" "	Ng,Avn	Ng		
070 0 214	502214	"	"	"	"	"	"	"	10500	" "	Ab	Ar		
070 0 216	502216	"	"	"	"	"	"	"	10000	" "	"	"		
070 0 218	502218	1948	Tatra	4500	8800	24000	19,9	23,6	12100	TB, "	Kd	Ar	RIV	
070 0 219	502219	"	"	"	"	"	21,2	25,0	10800	" "	Fn	Kh	"	
070 0 220	502220	"	"	"	"	"	20,1	23,8	11900	" "	Gb,Prø	"	"	
070 0 221	502221	"	"	"	"	"	20,0	23,7	12000	" "	"	"	"	
070 0 222	502222	"	"	"	"	"	19,8	23,5	12200	" "	Kd	Ar	"	
070 0 223	502223	"	"	"	"	"	19,7	23,4	12300	" "	"	"	"	
070 0 224	502224	"	"	"	"	"	20,2	23,9	11800	" "	"	"	"	
070 0 225	502225	"	"	"	"	"	19,9	23,6	12100	" "	Gb,Prø	Kh	"	
070 0 226	502226	"	"	"	"	"	20,1	23,8	11900	" "	"	"	"	
070 0 227	502227	"	"	"	"	"	20,0	23,7	12000	" "	"	"	"	
070 0 228	502228	"	"	"	"	"	20,3	24,0	11700	" "	"	"	"	
070 0 229	502229	"	"	"	"	"	20,1	23,8	11900	" "	"	"	"	
070 0 230	502230	"	"	"	"	"	19,9	23,6	12100	" "	"	"	"	
070 0 231	502231	"	"	"	"	"	21,2	25,0	10800	" "	"	"	"	
070 0 232	502232	"	"	"	"	"	"	"	"	" "	"	"	"	
070 0 233	502233	"	"	"	"	"	21,3	"	10700	" "	"	"	"	
070 0 234	502234	"	"	"	"	"	21,2	"	10800	" "	"	"	"	
070 0 235	502235	"	"	"	"	"	19,9	23,6	12100	" "	"	"	"	
070 0 236	502236	"	"	"	"	"	20,2	23,9	11800	" "	Kd	Ar	"	
070 0 237	502237	"	"	"	"	"	"	"	"	" "	"	"	"	

070 0 238	502238	1949	Scandia	5000	8630	24000	21,4	22,0	10600	TB, RS,	Gb,Prø	Kh	RIV
070 0 239	502239	"	"	"	"	"	21,7	"	10300	" "	Fn	"	"
070 0 240	502240	"	"	"	"	"	21,3	"	10700	" "	Ng,Avn	Ng	"
070 0 241	502241	"	"	"	"	"	21,4	"	10600	" "	Gb,Prø	Kh	"
070 0 242	502242	"	"	"	"	"	21,0	"	11000	" "	Ng,Avn	Ng	"
070 0 243	502243	"	"	"	"	"	"	"	"	" "	Gb,Prø	Kh	"
070 0 244	502244	"	"	"	"	"	21,4	"	10600	" "	Ng,Avn	Ng	"
070 0 245	502245	"	"	"	"	"	21,3	"	10700	" "	"	"	"
070 0 246	502246	"	"	"	"	"	21,4	"	10600	" "	Gb,Prø	Kh	"
070 0 247	502247	"	"	"	"	"	"	"	"	" "	Ng,Avn	Ng	"
070 0 249	502249	1916	Hannover	3800	8000	18000	15,0	15,0	10400	TL, "	Fn	Kh	"
070 0 250	502250	"	"	"	"	"	"	"	10100	" "	Ng,Avn	Ng	"
070 0 252	502252	"	"	"	"	"	"	"	10600	" "	"	"	"
070 0 253	502253	"	"	"	"	"	16,8	16,8	11200	TB, "	Gb,Prø	Kh	RIV
070 0 254	502254	1917	Zwickau	4000	8800	"	15,7	15,7	11000	TL, "	Fn	"	"
070 0 256	502256	1918	Wismar	4500	9800	18900	"	"	12000	TB, "	Ar	Ar	"
070 0 258	502258	"	"	"	"	"	16,8	16,8	12200	" "	Ab	"	"
070 0 260	502260	"	Linke-Hofmann	4000	8800	19000	"	"	11300	" "	Gb,Prø	Kh	"
070 0 264	502264	1917	Zwickau	"	"	18000	15,7	15,7	10500	TL, "	Es	Ar	"
070 0 266	502266	1918	Wismar	4500	9800	18900	"	"	11800	TB, "	Fn	Kh	RIV
070 0 267	502267	1916	Bautzen	4000	8800	17700	"	"	11200	TL, "	Es	Ng	"
070 0 268	502268	1918	Beuchel	"	"	18900	"	"	11500	" "	Gb,Prø	Kh	"
070 0 270	502270	"	Scandia	4500	8460	14200	11,8	11,8	8700	" "	Ar	Ar	"
070 0 272	502272	1931	Wismar	4000	8800	18000	17,8	17,8	14200	TB, "	"	"	"
070 0 273	502273	"	"	"	"	"	"	"	13500	" "	Kd	"	"
070 0 274	502274	"	"	"	"	"	17,7	"	14300	" "	Gb,Prø	Kh	"
070 0 275	502275	"	"	"	"	"	17,8	"	13400	" "	"	"	RIV
070 0 277	502277	"	"	"	"	"	17,1	17,1	"	TL, "	"	"	"
070 0 279	502279	"	"	"	"	"	17,8	17,8	13800	" "	Kd	Ar	"
070 0 280	502280	"	"	"	"	"	"	"	"	TB, "	"	"	RIV
070 0 281	502281	"	"	"	"	"	17,4	"	14600	" "	Gb,Prø	Kh	"
070 0 282	502282	"	"	"	"	"	17,2	17,2	14200	" "	Kd	Ar	"
070 0 283	502283	"	"	"	"	"	17,8	17,8	13600	" "	Gb	Kh	RIV
070 0 284	502284	"	"	"	"	"	"	"	13200	TL, "	Gb,Prø	"	"
070 0 285	502285	"	"	"	"	"	17,7	"	14300	TB, "	"	"	RIV
070 0 401	502401	1903	Herbrand	"	9050	15460	11,9	11,9	10200	TL, "	Hk	"	"
070 0 407	502407	1904	Zypen	"	8830	15000	12,6	12,6	9200	" "	Ng,Avn	Ng	"
070 0 412	502412	1905	Herbrand	"	9050	15350	13,1	13,1	9600	" "	"	"	"

Nyt nummer	Gl. nummer	Bygningsår	Fabrikationssted	Akselafstand	Længde over puffernes stødflader	Rumindhold	Lastgrænse			Omtrentlig taravægt kg	Bremse og varme	Hjemsted	Værkstedsområde	Anmærkning
				mm	mm	l	A	B	C					
070 0 413	502413	1905	Herbrand	4000	9050	15350	13,1	13,1	9600	TL, RS	Ng,Avn	Ng		
070 0 420	502420	1914	Werdau	4000	8900	16000	15,4	15,4	10200	" "	Ab	Ar		
070 0 423	502423	1930	Wismar	"	8800	19000	18,9	18,9	11500	" "	Fn	Kh		
070 0 424	502424	"	"	"	"	"	"	"	12200	TB, "	Ng,Avn	Ng	RIV	
070 0 425	502425	"	"	"	"	"	"	"	11800	" "	Fn	Kh		
070 0 428	502428	"	"	"	"	"	16,8	16,8	14700	" "	Kd	Ar	"	
070 0 430	502430	"	"	"	"	"	"	"	14500	" "	"	"	"	
070 0 432	502432	"	"	"	"	"	18,9	18,9	11800	" "	Ar	"		
070 0 433	502433	"	"	"	"	"	"	"	"	" "	"	"		
070 0 441	502441	1912	Cassel	4500	9300	15200	15,7	15,7	9700	TL, "	"	"		
070 0 444	502444	1904	Maribo	"	7850	"	11,0	11,0	8700	" "	Ng,Avn	Ng		
070 0 445	502445	1915	Hannover	3500	7620	15600	15,7	15,7	9700	" "	"	"		
070 0 449	502449	"	"	4500	9320	15200	"	"	10000	" "	"	"		
070 0 451	502451	"	"	4000	8820	18000	"	"	9900	" "	"	"		
070 0 452	502452	1913	Zypen	"	8610	"	15,3	15,3	10300	" "	Fn	Kh		
070 0 454	502454	1914	"	"	8560	"	"	"	9900	" "	Ab	Ar		
070 0 455	502455	1910	Wismar	"	8840	17400	15,2	15,2	10000	" "	Ng,Avn	Ng		
070 0 456	502456	1911	Zypen	"	8620	18000	15,4	15,4	9900	" "	"	"		

ZE 502502-508 se side 233 Akt. Kemisk Industri

Vognejer: **A/S Kalundborg Olieraffinaderi, Kalundborg.** Vognene er påmalet ejerens navn.

6 beholdervogne. I vognene må befordres: *Asfalt og brændselolie i vognladninger.*

070 0 551	502551			4200	8750	17300	13,6	13,6	12000	TB, RS	Kb	Kh	
070 0 552	502552	1948	Tatra	4500	8800	24000	20,2	23,9	11800	" "	"	"	RIV
070 0 553	502553	"	"	"	"	"	20,1	23,8	11900	" "	"	"	"
070 0 554	502554	"	"	"	"	"	20,2	23,9	11800	" "	"	"	"
070 0 555	502555	"	"	"	"	"	"	"	"	" "	"	"	"
070 0 556	502556	"	"	"	"	"	"	"	"	" "	"	"	"

Vognejer: **Svendborg Tagpapfabrik, Svendborg.** Vognene er påmalet ejerens navn.

3 beholdervogne. I vognene må befordres: *Tjære og tjæreprodukter.*

070 0 676	502676	1916	Aachen	3700	8300	15000	15,7	15,7	11700	TB, RS	Svg	Ng	
070 0 677	502677	1904	Cöhlh	4000	9060	"	"	"	9500	TL "	"	"	
070 0 678	502678		Wawara Werningerode	"	8830	19200	17,7	17,8	14300	TB S	"	"	

Vognejer: **Polypren A/S, København.** Vognen er påmalet ejerens navn.

1 beholdervogn. I vognen må befordres: *Gummitatex.*

070 0 686	502686	1942	Aachen	4500	8800	20000	18,9	18,9	12900	TB, RS, L	Gb	Kh	RIV
-----------	--------	------	--------	------	------	-------	------	------	-------	-----------	----	----	-----

Vognejer: **B. Ringsted & Co, København.** Vognen er påmalet ejerens navn.

1 beholdervogn. I vognen må befordres: *Olieprodukter og opløsningsmidler i. h. t. R. I. D. Klasse III a.*

070 0 721	502721	1944	Saarbrücken	4500	8800	24000	21,0	21,0	9600	TB, RS	Gb, Prø	Kh	
-----------	--------	------	-------------	------	------	-------	------	------	------	--------	---------	----	--

Vognejer: **Colas Vejmateriale A/S.** Vognene er påmalet ejerens navn.

1 beholdervogn. I vognen må befordres: *Tjære, tjæreolier og asfalt.*

070 0 772	502772		E.V.A.	4000	9070	15000	15,7	15,7	10200	TB, RS	Gb	Kh	
-----------	--------	--	--------	------	------	-------	------	------	-------	--------	----	----	--

Nyt nummer	Gl. nummer	Bygningsår	Fabrikationssted	Aksel-	Længde	Rum-	Lastgrænse			Omtrentlig taravægt	Bremse og varme	Hjemsted	Værk-	Anmærkning
				afstand	over puffernes stødfalder		indhold	A	B					
				mm	mm	l	t			kg				

Vognejer: **A/S Dansk Shell, København.** Vognene er påmalet ejerens navn.

141 beholdervogne. I vognene må befordres: *Benzin, brændselolie, smøreolie, petroleum, sprit og asfalt.*

070 0 808	502808			4000	8330	19100	16,2	16,2	10800	TL, RS	Fa	Ar	RIV
070 0 809	502809	1940	Posen	4500	8740	18000	15,7	15,7	11800	" "	"	"	"
070 0 810	502810	1938	Linke Hofmann	"	8750	19200	17,8	17,8	11900	TB " L	"	"	"
070 0 811	502811	"	"	"	8670	"	"	"	12000	" "	"	"	"
070 0 812	502812	1941	Mainz	"	8800	"	"	"	11900	" "	"	"	"
070 0 813	502813	1942	Aachen	"	8650	"	"	"	12000	" "	"	"	"
070 0 814	502814	1941	Budapest	"	8810	22000	18,9	18,9	11600	TL "	"	"	"
070 0 815	502815	"	"	"	8800	20000	"	"	11300	" "	"	"	"
070 0 816	502816	"	Belgien	"	8950	"	"	"	"	" "	"	"	"
070 0 817	502817	"	"	"	8700	26500	"	"	11900	" "	"	"	"
070 0 818	502818	"	"	"	8790	"	"	"	"	" "	"	"	"
070 0 819	502819	"	"	"	8830	22000	14,7	14,7	11400	" "	"	"	"
070 0 820	502820	1942	Danzig	"	8750	"	18,9	18,9	12200	TB "	"	"	"
070 0 821	502821	1943	Scandia	"	8800	"	"	"	12100	" "	"	"	"
070 0 822	502822	1942	Quedlingburg	"	"	20000	"	"	12200	" "	"	"	"
070 0 823	502823	1941	Uerdingen	"	8870	30000	22,0	22,0	9900	" "	"	"	"
070 0 824	502824	1939	"	"	8415	"	"	"	9500	" "	"	"	"
070 0 825	502825	1941	Nürnberg	"	8770	"	"	"	9700	" "	"	"	"
070 0 826	502826	1942	Saarbrücken	"	8800	"	"	"	"	" "	"	"	"
070 0 827	502827	1944	"	"	8840	24000	"	"	9500	" "	"	"	"
070 0 828	502828			"	8810	"	21,7	"	10300	" "	"	"	"
070 0 829	502829	1943	Belgien	"	"	"	21,9	"	10100	" "	"	"	"
070 0 830	502830	"	M.A.N.	"	8750	30000	"	"	"	" "	"	"	"
070 0 831	502831	"	Graz	"	8790	24000	"	23,0	"	" "	"	"	"
075 0 832	502832	1941	Köln	6,6+2m	12400	63000	46,0	46,2	18000	" "	"	"	"
075 0 833	502833	"	Uerdingen	"	12350	"	"	"	17300	" "	"	"	"

070 0 834	502834	1944	Scandia	4000	7540	16200	18,9	18,9	11400	TL, RS	Fa	Ar	RIV
070 0 835	502835	1951	Falkenberg	5000	9200	23000	18,5	22,3	13500	TB, " L	"	"	"
070 0 836	502836	"	"	"	"	"	"	"	13300	" " "	"	"	"
070 0 837	502837	"	"	"	"	"	"	"	13500	" " "	"	"	"
070 0 838	502838	"	"	"	"	"	"	"	13300	" " "	"	"	"
070 0 839	502839	"	"	"	"	"	"	"	"	" " "	"	"	"
070 0 840	502840	"	"	"	"	"	"	"	13400	" " "	"	"	"
070 0 841	502841	"	"	"	"	"	18,9	22,5	13100	" " "	"	"	"
070 0 842	502842	"	"	"	"	"	18,7	"	13300	" " "	"	"	"
070 0 843	502843	"	"	"	"	"	18,5	"	13500	" " "	"	"	"
070 0 844	502844	"	"	"	"	"	18,6	"	13400	" " "	"	"	"
070 0 845	502845	"	"	"	"	"	18,5	"	13500	" " "	"	"	"
070 0 846	502846	"	"	"	"	"	18,3	22,2	13700	" " "	"	"	"
070 0 847	502847	"	"	"	"	"	18,6	22,5	13400	" " "	"	"	"
070 0 848	502848	"	"	"	"	"	"	"	"	" " "	"	"	"
070 0 849	502849	"	"	"	"	"	"	"	"	" " "	"	"	"
070 0 850	502850	1948	Scandia	"	8630	24000	21,1	22,0	10900	" " "	"	"	"
070 0 851	502851	"	"	"	"	"	"	"	"	" " "	"	"	"
070 0 852	502852	"	"	"	"	"	"	"	"	" " "	"	"	"
070 0 853	502853	"	"	"	"	"	21,3	"	10700	" " "	"	"	"
070 0 854	502854	"	"	"	"	"	21,5	"	10500	" " "	"	"	"
070 0 855	502855	"	"	"	"	"	"	"	"	" " "	"	"	"
070 0 856	502856	"	"	"	"	"	21,6	"	10400	" " "	"	"	"
070 0 857	502857	"	"	"	"	"	21,5	"	10500	" " "	"	"	"
070 0 858	502858	"	"	"	"	"	"	"	"	" " "	"	"	"
070 0 859	502859	"	"	"	"	"	21,6	"	10400	" " "	"	"	"
070 0 860	502860	"	"	"	"	"	21,5	"	10500	" " "	"	"	"
070 0 861	502861	"	"	"	"	"	"	"	"	" " "	"	"	"
070 0 862	502862	"	"	"	"	"	"	"	"	" " "	Gb,Prø	Kh	"
070 0 863	502863	"	"	"	"	"	"	"	"	" " "	Fa	Ar	"
070 0 864	502864	"	"	"	"	"	"	"	"	" " "	"	"	"
070 0 865	502865	"	"	"	"	"	21,4	"	10600	" " "	"	"	"
070 0 866	502866	"	"	"	"	"	"	"	"	" " "	"	"	"
070 0 867	502867	"	"	"	"	"	"	"	"	" " "	"	"	"
070 0 868	502868	"	"	"	"	"	21,6	"	10400	" " "	"	"	"

Nyt nummer	Gl. nummer	Bygningsår	Fabrikationssted	Aksel-	Længde	Rum-	Lastgrænse			Omtrentlig taravægt	Bremse og varme	Hjemsted	Værkstedsområde	Anmærkning	
				af-	over		indhold	A	B						C
				stand	puffernes		l	t							
mm	stodflader	mm				kg									
070 0 869	502869	1948	Scandia	5000	8630	24000	21,5	22,0	10500	TB, RS	Fa	Ar	RIV		
070 0 870	502870	1949	"	"	8820	"	18,2	19,9	13800	" " L	"	"	"		
070 0 871	502871	"	"	"	"	"	"	"	"	" " "	"	"	"		
070 0 872	502872	"	"	"	"	"	18,3	"	13700	" " "	"	"	"		
070 0 873	502873	"	"	"	"	"	"	"	"	" " "	"	"	"		
070 0 874	502874	"	"	"	"	"	18,2	"	13800	" " "	"	"	"		
070 0 875	502875	"	"	"	"	"	"	"	"	" " "	"	"	"		
070 0 876	502876	"	"	"	"	"	18,3	"	13700	" " "	"	"	"		
070 0 877	502877	"	"	"	"	"	"	"	"	" " "	"	"	"		
070 0 878	502878	"	"	"	"	"	18,5	"	13500	" " "	"	"	"		
070 0 879	502879	"	"	"	"	"	18,4	"	13600	" " "	"	"	"		
070 0 880	502880	1941	"	4500	8460	19200	16,2	16,2	12700	TL, "	Gb, Prø	Kh	"		
070 0 881	502881	"	"	"	"	"	"	"	12900	" "	"	"	"		
070 0 882	502882	"	"	"	"	"	"	"	"	" "	"	"	"		
070 0 883	502883	"	"	"	"	"	"	"	"	" S	"	"	"		
070 0 884	502884	"	"	"	"	"	"	"	12800	" "	"	"	"		
070 0 885	502885	"	"	"	"	"	"	"	12900	" "	"	"	"		
070 0 886	502886	"	"	"	"	"	"	"	"	" RS	"	"	"		
070 0 887	502887	1931	"	"	"	"	17,8	17,8	12300	TB, "	"	"	"		
070 0 888	502888	"	"	"	"	"	"	"	11900	" "	"	"	"		
070 0 889	502889	"	"	"	"	"	"	"	"	" S	"	"	"		
070 0 890	502890	"	"	"	"	"	"	"	12000	" RS	"	"	"		
070 0 891	502891	"	"	"	"	"	"	"	12200	" S	"	"	"		
070 0 892	502892	"	"	"	"	"	"	"	"	" RS	"	"	"		
070 0 893	502893	"	"	"	"	"	"	"	"	" S	"	"	"		
070 0 894	502894	"	"	"	"	"	"	"	11200	" RS	"	"	"		
070 0 895	502895	"	Dessau	4000	8800	"	18,9	18,9	12500	" S	"	"	"		
070 0 898	502898	"	"	"	"	"	"	"	11200	TL, RS	"	"	"		
070 0 899	502899	"	"	"	"	"	"	"	12600	TB, "	"	"	"		
070 0 903	502903	"	"	"	"	"	"	"	11900	TL, S	"	"	"		
070 0 905	502905	1930	Gotha	"	"	19000	14,6	14,6	12200	TB, "	Fa	Ar	"		
070 0 906	502906	"	"	"	"	19200	14,2	14,2	12100	" "	"	"	"		
070 0 907	502907	"	"	"	"	"	"	"	12300	" "	"	"	"		
070 0 908	502908	"	"	"	"	"	"	"	11800	" RS	"	"	"		
070 0 909	502909	"	"	"	"	"	"	"	12000	" "	"	"	"		



070 0 910	502910	1930	Gotha	4000	8800	19200	14,2	14,2	12100	TB, S	Fa	Ar	RIV
070 0 911	502911	"	"	"	"	"	"	"	12300	" "	"	"	"
070 0 912	502912	"	"	"	"	"	"	"	12400	" "	"	"	"
070 0 913	502913	"	"	"	"	"	"	"	12300	" "	"	"	"
070 0 915	502915	"	"	"	"	"	"	"	11900	TL "	"	"	"
070 0 917	502917	"	"	"	"	"	"	"	11200	" RS	"	"	"
070 0 918	502918	"	"	"	"	"	"	"	12000	" S	"	"	"
070 0 920	502920	"	Wismar	"	"	"	18,9	18,9	11900	" "	"	"	"
070 0 922	502922	"	"	"	"	"	"	"	11800	" "	"	"	"
070 0 923	502923	"	"	"	"	"	"	"	11400	" RS	"	"	"
070 0 924	502924	"	"	"	"	"	"	"	11800	" S	"	"	"
070 0 925	502925	"	"	"	"	"	"	"	11900	" "	"	"	"
070 0 926	502926	"	"	"	"	"	"	"	12000	" "	"	"	"
070 0 927	502927	"	"	"	"	"	"	"	11400	" RS	"	"	"
070 0 929	502929	"	"	"	"	"	"	"	11500	" "	"	"	"
070 0 932	502932	1914	Zypen	"	8600	18000	16,8	16,8	10700	" "	Gb,Prø	Kh	"
070 0 936	502936	1921	Krupp	"	8100	19000	17,8	17,8	11100	" S	"	"	"
070 0 937	502937	"	"	"	"	"	"	"	10700	" RS	"	"	"
070 0 938	502938	"	"	"	"	"	"	"	10900	" "	"	"	"
070 0 939	502939	1919	Zypen	4200	9100	19200	14,7	14,7	11200	" S	Fa	Ar	"
070 0 942	502942	1920	"	4000	8800	19000	"	"	10600	" RS	Gb,Prø	Kh	"
070 0 943	502943	"	"	"	"	"	"	"	10800	" "	"	"	"
070 0 944	502944	1919	"	4200	9100	19200	14,6	14,6	11000	" S	Fa	Ar	"
070 0 945	502945	"	"	"	"	"	"	"	10900	" "	"	"	"
070 0 953	502953	1913	"	3800	8340	15000	11,0	11,0	10100	" RS	"	"	"
070 0 954	502954	1916	"	4200	9100	19200	14,7	14,7	10700	" "	Gb,Prø	Kh	"
070 0 956	502956	"	"	"	"	"	"	"	10800	" "	"	"	"
070 0 957	502957	"	"	"	"	"	"	"	"	" S	Fa	Ar	"
070 0 958	502958	"	"	"	"	"	"	"	10900	" "	"	"	"
070 0 960	502960	"	"	"	"	"	"	"	11200	" RS	Gb,Prø	Kh	"
070 0 961	502961	"	"	"	"	"	"	"	10600	" "	Fa	Ar	"
070 0 963	502963	"	Cassel	4500	9300	19500	14,5	14,5	10700	" "	Gb,Prø	Kh	"
070 0 964	502964	"	M.A.N.	4000	8300	19200	"	"	10900	" S	"	"	"
070 0 966	502966	"	"	"	"	"	"	"	10700	" RS	Fa	Ar	"
070 0 969	502969	"	Bremen	"	8800	19500	14,3	14,3	11600	" "	"	"	"
070 0 971	502971	1911	Siegen	"	"	15000	15,3	15,3	10100	" "	Gb,Prø	Kh	"
070 0 972	502972	"	"	"	"	"	"	"	9800	" "	"	"	"
070 0 976	502976	1919	Zypen	4200	9100	19200	14,6	14,6	11400	" S	"	"	"
070 0 983	502983	1928	Gotha	4000	8800	19000	15,7	15,7	11800	" "	Fa	Ar	"
070 0 984	502984	"	"	"	"	"	"	"	11500	" RS	"	"	"

Nyt nummer	Gl. nummer	Bygningsår	Fabrikationssted	Akselafstand	Længde over puffernes stødflader	Rumindhold	Lastgrænse			Omtrentlig taravægt kg	Bremse og varme	Hjemsted	Værkstedsområde	Anmærkning
				mm	mm	l	A	B	C					
070 0 987	502987	1913	Gotha	4000	8800	19000	15,7	15,7	11700	TL, S	Fa	Ar	RIV	
070 0 988	502988		"	"	"	"	"	"	11100	" RS	"	"	"	
070 0 996	502996	1942	Scandia	4500	"	22000	18,9	18,9	12500	" "	"	"	"	
070 0 997	502997	"	"	"	"	"	"	"	11600	" "	"	"	"	
070 0 998	502998	1937	"	4000	7470	16200	"	"	11300	TB "	"	"	"	

Vognejer: **Caltex Oil A/S, København.** Vognene er påmalet ejerens navn.

2 beholdervogne. I vognene må befordres: *Benzin, petroleum, gasolie, dieselolie og smørelie.*

070 1 041	503041	1921	Wismar	4000	8790	17000	15,7	15,7	11300	TL, RS	Gb, Prø	Kh	RIV
070 1 042	503042	1919	Zypen	4200	9120	19200	14,6	14,6	10700	" "	"	"	"

Vognejer: **Danske Gasværkers Tjære Kompagni A/S, Nyborg.** Vognene er påmalet ejerens navn.

11 beholdervogne. I vognene må befordres: *Tjære og tjæreprodukter samt asfalt og asfaltprodukter.*

070 1 103	503103	1916	Gotha	3500	7800	8900	13,7	13,7	12000	TL	RS	Ng	Ng	RIV
070 1 104	503104	"	"	"	"	"	"	"	11500	"	"	"	"	"
070 1 105	503105	"	"	"	"	"	"	"	11400	"	"	"	"	"
070 1 106	503106	"	"	"	"	"	"	"	11900	"	S	"	"	"
070 1 109	503109	"	"	"	"	"	"	"	11700	"	RS	"	"	"
070 1 110	503110	"	"	"	"	"	"	"	11800	"	S	"	"	"
070 1 111	503111	1931	Zypen	4000	8800	15400	17,5	17,7	14500	TB	"	"	"	"
070 1 112	503112	"	"	"	"	"	"	"	"	"	"	"	"	"
070 1 113	503113	"	"	"	8700	15000	18,9	18,9	11500	"	"	"	"	"
070 1 114	503114	1903	Berlin	"	8830	"	17,3	17,3	12300	"	"	L	"	"
070 1 115	503115	"	Uerdingen	"	8800	"	15,7	15,7	12000	TL,	RS"	"	"	"

Nyt nummer	Gl. nummer	Bygningsår	Fabrikationssted	Akselafstand	Længde over puffernes stødflader	Rumindhold	Lastgrænse			Omtrentlig taravægt	Bremse og varme	Hjemsted	Værkstedsområde	Anmærkning
							A	B	C					
				mm	mm	l	t			kg				

Vognejer: **Phønix A/S, Vejen.** Vognene er påmalet ejerens navn.

5 beholdervogne. I vognene må befordres: *Tjære, tjæreolie, solarolie og asfalt.*

070 1 121	503121	1913	Zwickau	4000	8800	16000	17,8	17,8	10700	TL, RS	Vn	Ar	
070 1 126	503126			"	8820	15000	16,8	16,8	10400	" "	"	"	
070 1 127	503127			"	8800	"	"	"	11600	" S	"	"	
070 1 128	503128	1908	E.V.A.	"	8840	"	17,8	17,8	12200	" RS	"	"	RIV
070 1 129	503129	1916	Ammendorf	"	8800	17500	15,7	15,7	13300	" "	"	"	

Vognejer **A/S Frisenborg Fabriker, Ikast.** Vognen er påmalet ejerens navn.

1 beholdervogn. I vognen må befordres: *Tjære og tjæreolie.*

070 1 131	503131	1904	Ehrendfeld	4000	9050	15500	15,7	15,7	9700	TL, RS	Ik	Ar	RIV
-----------	--------	------	------------	------	------	-------	------	------	------	--------	----	----	-----

Vognejer: **Gulf Oil A/S, København.** Vognene er påmalet ejerens navn.

28 beholdervogne. I vognene må befordres: *Brændselolie, smøreolie, benzin og petroleum.*

070 1 215	503215	1948	Scandia	5000	8630	20000	18,9	18,9	10300	TB	RS	Ab	Ar	
070 1 216	503216	"	"	"	"	"	"	"	"	"	"	Gb,Prø	Kh	
070 1 217	503217	"	"	"	"	"	"	"	"	"	"	"	"	
070 1 218	503218	"	"	"	"	"	"	"	10200	"	"	"	"	
070 1 219	503219	"	"	"	"	"	"	"	"	"	"	"	"	
070 1 220	503220	"	"	"	"	"	"	"	10300	"	"	"	"	
070 1 221	503221	"	"	"	"	"	"	"	10200	"	"	Es	Ar	
070 1 222	503222	"	"	"	"	"	"	"	10300	"	"	"	"	
070 1 223	503223	"	"	"	"	"	"	"	11000	"	"	Ar	"	RIV
070 1 224	503224	"	"	"	"	"	"	"	10300	"	"	Es	"	
070 1 225	503225	"	"	"	"	"	"	"	"	"	"	"	"	
070 1 226	503226	1949	"	"	"	"	"	"	10200	"	"	Ar	"	
070 1 231	503231	"	"	"	"	"	"	"	10900	"	"	"	"	
070 1 235	503235	"	"	"	"	"	"	"	10200	"	"	"	"	
070 1 239	503239	"	"	"	"	"	"	"	"	"	"	"	"	
070 1 242	503242	"	"	"	"	"	"	"	"	"	"	"	"	RIV
070 1 245	503245	1946	Chr. Olsson	"	9000	28000	21,0	21,0	11100	"	"	Es	"	
070 1 246	503246	"	"	"	"	"	"	"	"	"	"	Ar	"	
070 1 247	503247	1947	"	"	"	"	"	"	11000	TL	"	"	"	
070 1 248	503248	"	"	"	"	"	"	"	11300	TB	"	"	"	
070 1 249	503249	"	"	"	"	"	"	"	"	TL	"	Es	"	
070 1 250	503250	"	"	"	"	"	"	"	10900	"	"	Ar	"	
070 1 251	503251	1931	Orenstein	4000	8800	19200	20,0	20,0	11100	"	"	Ab	"	
070 1 252	503252	1933	"	"	"	"	"	"	11200	"	"	Es	"	
070 1 253	503253	"	"	"	"	"	"	"	"	"	"	Gb,Prø	Kh	
070 1 254	503254	"	"	"	"	"	"	"	"	"	"	Fn	"	
070 1 255	503255	"	"	"	"	"	"	"	11000	"	"	Gb,Prø	"	
070 1 256	503256	"	"	"	"	"	"	"	11700	"	"	Es	Ar	

Nyt nummer	Gl. nummer	Bygningsår	Fabrikationssted	Aksel-	Længde	Rum-	Lastgrænse			Omtrentlig taravægt	Bremse og varme	Hjemsted	Værkstedsområde	Anmærkning	
				af-	over		indhold	A	B						C
				stand	puffernes stødfalder		l	t							kg

Vognejer: **Jydsk Andels-Foderstofferforretning, Axelborg, København V.** Vognene er påmalet ejerens navn.

6 beholdervogne. I vognene må befordres: *Benzin, mineralsk olie, animalsk olie, fedt, vegetabilsk olie, tjære, brændselolie, petroleum, varm asfalt, varm tjære og melasse.*

070 1 295	503295	1936	Køln	4500	8900	20000	18,9	18,9	12000	TB, RS, L	Ar	Ar
070 1 296	503296	1938	Bautzen	"	8800	"	"	"	12200	" "	"	"
070 1 297	503297	1923	Saarbrücken	3750	8120	21000	17,8	17,8	11200	TL "	Es	"
070 1 298	503298	1944	"	4500	8800	24000	21,9	22,0	10100	TB " L	Rd	"
070 1 299	503299	1936	Scandia	"	8460	14000	19,9	19,9	10900	TL "	"	"
070 1 300	503300	1915	Zypen	4000	8270	17000	17,8	17,8	10200	" "	Ab	"

Vognejer: **BP Olie-Kompagniet A/S, København.** Vognene er påmalet ejerens navn.

36 beholdervogne. I vognene må befordres: *Benzin, petroleum, diesellole, brændselolie, smøreolie, melasse, benzol og asfalt.*

070 1 341	503341	1919	Aachen	4000	8800	19000	16,0	16,0	11900	TB, RS	Fa	Ar	RIV
070 1 342	503342	1929	Wismar	"	"	19200	18,9	18,9	12100	" S	"	"	"
070 1 346	503346	"	"	"	"	"	"	"	12000	" RS	"	"	"
070 1 347	503347	"	"	"	"	"	"	"	"	" "	"	"	"
070 1 348	503348	"	"	"	"	"	"	"	"	" "	Gb,Prø	Kh	"
070 1 349	503349	"	"	"	"	"	"	"	11600	" "	Fa	Ar	"
070 1 350	503350	"	"	"	"	"	15,7	15,7	11200	" "	"	"	"
070 1 352	503352	1948	Belgien	4600	7850	20000	20,3	21,8	11700	TB " L	"	"	"
070 1 353	503353	"	"	"	"	"	19,5	21,5	12400	" " "	"	"	"
070 1 354	503354	"	"	"	"	"	"	19,4	"	" " "	"	"	"
070 1 355	503355	"	"	"	"	"	20,4	21,5	11600	" " "	Gb,Prø	Kh	"
070 1 356	503356	"	"	"	"	"	20,0	21,6	"	" " "	Fa	Ar	"

070 1 357	503357	1948	Belgien	4600	8300	20000	20,2	21,3	11800	TB RS L	Gb,Prø	Kh	RIV
070 1 358	503358	"	"	"	"	"	19,4	19,4	12600	" " "	Fa	Ar	"
070 1 359	503359	"	"	"	"	"	20,4	21,4	11600	" " "	"	"	"
070 1 360	503360	"	"	"	"	"	18,8	20,8	12300	" " "	"	"	"
070 1 361	503361	"	"	"	"	"	18,1	21,4	"	" " "	Gb,Prø	Kh	"
070 1 362	503362	"	"	"	"	"	20,4	21,8	11600	" " "	"	"	"
070 1 363	503363	"	"	"	"	"	18,0	19,4	14000	" " "	Fa	Ar	"
070 1 364	503364	"	"	"	"	"	"	"	"	" " "	"	"	"
070 1 365	503365	"	"	"	"	"	20,5	21,5	11700	" " "	Ar	"	"
070 1 366	503366	"	"	"	"	"	20,3	21,3	11600	" " "	Gb,Prø	Kh	"
070 1 367	503367	"	"	"	8330	"	"	21,8	11700	" " "	"	"	"
070 1 368	503368	"	"	"	"	"	18,0	19,4	11500	" " "	Ab	"	"
070 1 369	503369	"	"	"	"	"	"	"	14000	" " "	Kk	Kh	"
070 1 370	503370	"	"	"	"	"	20,0	21,6	12000	" " "	"	"	"
070 1 371	503371	"	"	"	"	"	17,9	19,4	14100	" " "	"	"	"
070 1 372	503372	1903	Koeln-Erfurd	4000	9077	15000	12,6	12,6	9300	TL,RS	Fa	Ar	"
070 1 373	503373	1931	Dessau	"	8800	19200	18,9	18,9	11400	TB "	"	"	RIV
070 1 374	503374	1913	Zypen	3800	8340	15000	11,0	11,0	10100	TL "	"	"	"
070 1 375	503375	1928	Gotha	4000	8800	19000	15,7	15,7	11200	" "	Gb,Prø	Kh	"
070 1 376	503376	1913	"	"	15000	"	"	"	10100	TB "	Fa	Ar	"
070 1 378	503378	1930	"	"	19200	18,9	18,9	12100	" S	"	"	"	"
070 1 379	503379	1945	Scandia	5000	8530	"	17,8	17,8	11100	TB "	Ab	"	RIV
070 1 383	503383	1919	Werdau	3700	8000	"	16,8	16,8	10200	" "	Gb,Prø	Kh	"
070 1 384	503384	1906	Zypen	4000	"	19000	15,7	15,7	10800	" "	"	"	"

Vognejer: **BP Gas A/S, Havnegade 4, Århus.** Vognene er påmalet ejerens navn.

10 beholdervogne. I vognene må befordres: *Flydende gas med indtil 16,5 atm. tryk ved 50°C. Vognene er påmalet maksimallast for propan og butan.*

075 1 395	503395	1952	Falkenberg	7,8+2m	13500	50000	27,3	27,3	30800	TB, RS	Ar	Ar	RIV
075 1 396	503396	"	"	"	"	49880	"	"	"	" " "	"	"	"
075 1 397	503397	1951	"	7,0+2m	12700	45810	24,9	24,9	30000	" " "	"	"	"
075 1 398	503398	"	"	"	"	46200	25,3	25,3	29800	" " "	"	"	"
075 1 399	503399	1943	Wismar	8,8+2m	14600	52000	27,3	27,3	34400	" " "	"	"	"
075 1 401	503401	1952	Falkenberg	7,8+2m	13500	49750	26,0	26,0	30900	" " "	"	"	"
075 1 402	503402	"	"	"	13700	50000	"	"	30800	" " "	"	"	"
075 1 403	503403	"	"	"	13540	"	"	"	30700	" " "	"	"	"
075 1 404	503404	1953	"	7,0+2m	12700	46080	23,5	23,5	30400	" " "	"	"	"
075 1 405	503405	"	"	"	"	45880	"	"	"	" " "	"	"	"

Nyt nummer	Gl. nummer	Bygningsår	Fabrikationssted	Akselafstand	Længde over puffernes stødflader	Rumindhold	Lastgrænse			Omtrentlig taravægt	Bremsse og varme	Hjemsted	Værkstedsområde	Anmærkning
							A	B	C					
							mm	mm	l					

Vognejer: **Dansk Sojakagefabrik A/S, København.** Vognene er påmalet ejerens navn.

40 beholdervogne. I vognene må beforders: *Olie og fedt samt benzin, sæbelud, kalilud, terpentin, ammoniakvand af indtil 12 % styrke, melasse, samt fedtsyre og glycerin. Limvand og klor.*

070 1 501	503501	1930	Orenstein	4000	8800	19200	17,8	17,8	12800	TL, S	Gb	Kh	RIV
070 1 502	503502	"	Scandia	"	"	"	"	"	13400	"	"	"	"
070 1 503	503503	"	Orenstein	"	"	"	"	"	13100	"	RS	"	"
070 1 504	503504	1933	Scandia	4500	8470	"	"	"	12000	TB	"	"	"
070 1 505	503505	"	"	"	"	"	"	"	13500	"	"	"	"
070 1 506	503506	"	"	"	"	"	"	"	13900	"	"	"	"
070 1 507	503507	"	"	"	"	"	"	"	11400	"	"	"	"
070 1 508	503508	"	"	"	"	"	"	"	12800	"	"	"	"
070 1 509	503509	1934	"	"	"	"	"	"	"	TL	"	"	"
070 1 510	503510	"	"	"	"	"	"	"	"	"	"	"	"
070 1 511	503511	"	"	"	"	"	17,2	17,2	13400	"	"	"	"
070 1 512	503512	"	"	"	"	"	"	"	13000	"	"	"	"
070 1 513	503513	"	"	"	"	"	17,8	17,8	12600	"	L	"	"
070 1 514	503514	"	"	"	"	"	"	"	12400	"	"	"	"
070 1 515	503515	1935	"	"	"	"	17,2	17,2	13200	"	"	"	"
070 1 516	503516	"	"	"	"	"	17,8	17,8	12500	"	"	"	"
070 1 517	503517	"	"	"	"	"	"	"	12300	"	"	"	"
070 1 518	503518	"	"	"	"	"	"	"	12600	"	"	"	"
070 1 519	503519	1952	Falkenberg	5000	9200	23000	17,9	19,9	14100	TB	L	"	"
070 1 520	503520	"	"	"	"	"	"	"	"	"	"	"	"
070 1 521	503521	"	"	"	"	22400	"	21,9 22,0	"	"	"	"	"
070 1 522	503522	1944	Saarbrücken	4500	8800	24000	22,0	22,0	9900	"	"	"	RIV
070 1 523	503523	"	Werk Graz	"	"	"	"	23,1	10000	"	"	"	"
070 1 524	503524	1941	Kaminski	"	"	20000	18,7	18,9	13300	"	"	"	"
070 1 525	503525	1943	Belgien	"	"	24000	21,0	22,0	11000	"	"	"	"
070 1 526	503526	"	"	"	"	"	"	"	"	"	"	"	"
070 1 527	503527	1944	Saarbrücken	"	"	"	21,8	"	10200	"	"	"	"
070 1 528	503528	"	Werk Graz	"	"	"	21,9	23,1	10100	"	"	"	"
070 1 529	503529	1943	"	"	"	"	20,9	22,0	11100	"	"	"	"



070 1 530	503530	1944	Werk Graz	4500	8800	24000	22,1	23,1	9900	TB, RS, L	Gb	Kh	RIV
070 1 531	503531	"	"	"	"	"	"	"	"	"	"	"	"
070 1 532	503532	1943	Belgien	"	"	"	20,9	22,0	11100	"	"	"	"
070 1 533	503533	1944	Saarbrücken	"	"	"	21,0	"	11000	"	"	"	"
070 1 534	503534	1952	Kaminski	"	"	20000	19,9	19,9	10200	"	"	"	"
070 1 535	503535			"	"	24000	22,1	25,2	9900	TL	"	"	"
070 1 536	503536			"	"	"	"	"	"	"	"	"	"
070 1 537	503537			"	"	"	22,2	"	9800	"	"	"	"
070 1 538	503538	1957	Scandia	5000	8940	26000	21,3	25,3	10700	TB	"	"	"
070 1 539	503539	1961	"	"	"	"	21,1	25,1	10900	"	"	"	"
070 1 540	503540	"	"	"	"	"	"	"	"	"	"	"	"

Vognejer: **A/S Dansk Sojakagefabrik.** Vognene er påmalet ejerens navn.  
4 beholdervogne. I vognene må befordres: *Klor.*

070 1 550	503550	1952	Falkenberg	5500	9500	12800	15,9	15,9	14900	TB, RS	Gb	Kh	RIV
070 1 551	503551	1951	"	"	"	13000	"	"	14700	"	"	"	"
070 1 552	503552	1955	"	5100	9040	16000	19,1	19,9	12900	"	"	"	"
070 1 553	503553	"	"	"	"	"	"	"	"	"	"	"	"

Nyt nummer	Gl. nummer	Bygningsår	Fabrikationssted	Akselafstand	Længde over puffernes stødflader	Rumindhold	Lastgrænse			Omtrentlig taravægt	Bremse og varme	Hjemsted	Værkstedsområde	Anmærkning
				mm	mm	l	A	B	C					

Vognejer: **A/S De danske Spritfabrikker.** Vognene er påmalet ejerens navn.

19 beholdervogn. I vognene må beføres: *Melasse, akvavit, 96 % råsprit og 99,9 % absolut alkohol. 503 595, 25 % ammoniakvand.*

070 1 591	503591	1949	Scandia	5000	8630	13000	18,9	18,9	9500	TB, RS, L	Rd	Ar	
070 1 592	503592	"	"	"	"	"	"	"	"	" " "	"	"	
070 1 593	503593	"	"	"	"	"	"	"	"	" " "	"	"	
070 1 594	503594	"	"	"	"	"	"	"	9600	" " "	"	"	
070 1 595	503595	1947	"	"	"	"	"	"	9400	" " "	"	"	
070 1 596	503596	"	"	"	"	"	"	"	"	" " "	"	"	
070 1 597	503597	1946	"	"	"	"	"	"	9100	" " "	Sg	Kh	
070 1 598	503598	"	"	"	"	"	"	"	"	" " "	"	"	
070 1 599	503599	"	"	"	"	"	"	"	"	" " "	Gb	"	
070 1 600	503600	"	"	"	"	"	"	"	9500	" " "	"	"	
070 1 609	503609	1940	Uerdingen	4500	8800	20000	"	"	11800	TB, RS	"	"	
070 1 610	503610	1941	Heidelberg	"	"	"	"	"	11900	" " "	"	"	
070 1 611	503611	1940	Mainz	"	"	"	"	"	"	" " "	"	"	
070 1 612	503612	1939	Linke-Hofmann	"	"	"	"	"	"	" " "	"	"	ABC
072 2 613	503613	1956	Scandia	"	8640	16800	16,9	16,9	11600	" " "	"	"	S-last 16,0 t
072 2 614	503614	"	"	"	"	"	"	"	11500	" " "	"	"	» »
070 1 615	503615	1964	"	5000	8960	23000	19,5	22,0	12190	" " "	"	"	
070 1 616	"	1949	"	"	8630	20000	18,9	18,9	10100	" " "	"	"	
070 1 617	"	"	"	"	"	"	"	"	10300	" " "	"	"	

Vognejer: **A/S De danske Spritfabrikker.** Vognene er påmalet ejerens navn.

1 lukket godsvogn. I vognen må beføres: *Gær, eventuelt suppleret med mindre partier sprit.*

081 5 905	99705	1949	Scandia	6000	9290	20,3	19,0	19,0	11200	TB RS	Gb	Kh	hvidmalet
-----------	-------	------	---------	------	------	------	------	------	-------	-------	----	----	-----------

Vognejer: **Solofabrikken A/S**. Vognene er påmalet ejerens navn.  
 4 beholdervogne. I vognene må befordres: *Olie og fedt*.

070 1 651	503651	1914	Zypen	4100	8900	19000	15,7	15,7	13000	TL, RS	Sdb	Ar	RIV
070 1 652	503652	1922	Uerdingen	4000	8810	19200	"	"	13800	TB "	"	"	"
070 1 653	503653	1921	"	"	"	"	"	"	13000	TL "	"	"	"
070 1 654	503654	1920	Bremen	"	"	"	"	"	13800	TB "	"	"	"

Nyt nummer	Gl. nummer	Bygningsår	Fabrikationssted	Akselafstand	Længde over puffernes stødflader	Rumindhold	Lastgrænse			Omtrentlig taravægt	Bremse og varme	Hjemsted	Værkstedsområde	Anmærkning
							A	B	C					
							mm	mm	l					

Vognejer: **A/S Aarhus Oliefabrik.** Vognene er påmalet ejerens navn.

30 beholdervogne. I vognene må befordres: *Vegetabiliske og animalske olier, acetone, melasse, glycerin og natronlud.*

070 1 671	503671	1933	Scandia	4500	8460	19200	17,8	17,8	12600	TB, RS, L	Ar	Ar	RIV	
070 1 672	503672	"	"	"	"	"	"	"	12400	TL	"	"	"	
070 1 673	503673	1934	"	"	"	"	"	"	13000	TB	"	"	"	
070 1 674	503674	"	"	4260	8890	"	16,8	16,8	11400	TL S	"	"	"	
070 1 675	503675	"	"	"	"	"	"	"	11700	" RS	"	"	"	
070 1 676	503676	1934	Scandia	4500	8460	"	17,8	17,8	12400	"	"	"	"	
070 1 677	503677	1937	"	"	"	"	16,6	16,6	14000	TB S	"	"	"	
070 1 678	503678	"	"	"	"	"	17,3	17,3	13300	TL RS	"	"	"	
070 1 679	503679	"	"	"	"	"	"	"	"	"	"	"	"	
070 1 680	503680	1938	"	"	"	"	20,0	20,0	10800	"	"	"	"	
070 1 681	503681	"	"	"	"	"	16,8	16,8	13600	"	"	"	"	
070 1 682	503682	1953	"	5000	8530	"	17,8	17,8	13400	TB	"	"	"	
070 1 683	503683	"	"	"	"	"	"	"	"	"	"	"	"	
070 1 684	503684	1955	Falkenberg	"	9140	23000	20,2	24,2	28,2	11800	"	"	"	
070 1 685	503685	"	"	"	"	18000	21,4	25,4	28,9	10600	"	"	"	
070 1 686	503686	1957	Scandia	"	8640	23000	20,6	24,6	24,9	11400	"	"	"	
070 1 687	503687	"	"	"	"	"	"	"	24,8	"	"	"	"	
070 1 688	503688	"	"	"	"	"	20,5	24,5	24,8	11500	"	"	"	
072 2 689	503689	"	Kaminski	4500	8740	20000	18,9	22,9	23,1	13100	"	"	"	S-last A BC 18,9 22,5
070 1 690	503690	1958	Falkenberg	5000	9140	25300	18,1	22,1	26,1	13900	"	"	"	
070 1 691	503691	"	"	"	"	"	18,0	22,0	26,0	14000	"	"	"	
070 1 692	503692	"	"	"	"	"	18,1	22,1	26,1	13900	"	"	"	
072 2 693	503693	1961	"	5500	9440	"	18,8	22,8	26,8	13200	"	"	"	S-last 18,8 22,8
072 2 694	503694	"	"	"	"	"	"	"	"	"	"	"	"	» » »
078 5 695	503695	1963	"	"	"	"	18,2	"	26,2	13710	"	"	"	» 18,2 22,2
078 5 696	503696	"	"	"	"	"	"	22,2	"	13800	"	"	"	» » »
078 5 697	503697	"	"	"	"	"	18,0	22,0	26,0	13900	"	"	"	» 18,0 22,0
078 5 698	503698	"	"	"	"	"	"	"	"	"	"	"	"	» » »
072 2 699	503699	1964	"	"	"	"	18,7	22,7	26,7	13400	"	"	"	» 18,7 22,7
072 2 700	503700	"	"	"	"	"	18,4	22,4	26,4	13800	"	"	"	» 18,4 22,4

228—II

1) Udstyret for kørsel i Storbritannien

Vognejer: **A/S De forenede Benzinimportører, København.** Vognene er påmalet ejerens navn.

6 beholdervogne. I vognene må befordres: *Benzin, benzol, petroleum og anden brændselolie samt mineralolie og vegetabilsk olie.*

070 1 721	503721			4000	8800	19200	16,8	16,8	11800	TB, RS	Gb	Kh	RIV
070 1 722	503722	1941	Scandia	4500	8460	"	17,8	17,8	"	" "	"	"	"
070 1 723	503723	"	"	"	"	"	"	"	12400	" "	"	"	"
070 1 724	503724	"	"	"	8500	"	"	"	12100	" "	"	"	" Beholderen delt i 2 afd.
070 1 725	503725	1916	Werdau	3900	"	"	18,5	18,5	10900	TL "	"	"	"
070 1 726	503726	1941	Kaminski	4500		21000	"	"	12000	TB "	"	"	"

Vognejer: **Sprøjteselskabet af 1948 A/S, Kvistgård.**

1 beholdervogn. I vognen må befordres: *Cimazin og Aminotriazol.*

070 1 751	503751	1930	Orenstein	4000	8800	19600	19,0	19,0	12300	TL, RS	Kå	Kh	RIV Sprøjteaggregat trukket af benzinmotor
-----------	--------	------	-----------	------	------	-------	------	------	-------	--------	----	----	---

Vognejer: **Oliekompagniet Rhenania A/S, København K.** Vognene er påmalet ejerens navn.

7 beholdervogne. I vognene må befordres: *Benzin, benzol, petroleum, mineralske og vegetabiliske olier (herunder også smøreolier).*

070 1 801	503801	1942	Scandia	4500	8460	19200	17,8	17,8	11700	TB, S	Ar	Ar	RIV
070 1 802	503802	"	"	"	"	"	"	"	11500	TL "	Gb	Kh	"
070 1 803	503803	"	"	"	"	"	"	"	"	" "	"	"	"
070 1 804	503804	1943	"	"	"	"	"	"	11900	TB "	Ar	Ar	"
070 1 805	503805	"	"	"	"	"	"	"	11500	TL "	Gb	Kh	"
070 1 806	503806	1944	"	5000	"	"	"	"	"	" "	Ar	Ar	"
070 1 807	503807	"	"	"	"	"	"	"	11600	" "	"	"	"

Nyt nummer	Gl. nummer	Bygningsår	Fabrikationssted	Akselafstand	Længde over puffernes stødflader	Rumindhold	Lastgrænse			Omtrentlig taravægt kg	Bremse og varme	Hjemsted	Værkstedsområde	Anmærkning
				mm	mm	l	A	B	C					
							t							

Vognejer: **A/S Industriprodukter, København K.**

1 beholdervogn. I vognen må befordres: *Tallolie, trøtjære, vegetabilske- og terpentiner.*

070 1 811	503811	1919	Gotha	4000	8800	17400	19,0	19,0	11500	TL, RS	Ler	Kh	RIV
-----------	--------	------	-------	------	------	-------	------	------	-------	--------	-----	----	-----

Vognejer: **Dansk Ammoniakfabrik ved P. Korsgaard & Co., Nyborg.** Vognene er påmalet ejerens navn.

6 beholdervogne. I vognene må befordres: *Ammoniakvand.*

070 2 009	504009	1960	Scandia	5000	9060	18000	18,0	18,0	12000	TB, RS	Ng	Ng	
070 2 010	504010	1965	"	"	8940	12800	19,2	23,2	12800	" "	"	"	
070 2 011	504011	1960	"	"	9060	18000	18,0	18,0	12300	" "	"	"	
070 2 012	504012	1946	"	"	8930	17900	10,0	10,0	16300	" "	"	"	RIV
070 2 013	504013	"	"	"	"	18000	11,0	11,0	16800	" "	"	"	"
070 2 014	504014	1949	"	"	9400	19850	12,0	12,0	16700	" "	"	"	"

Vognejer: **Dansk-Norsk Borregård A/S, København V.**

8 beholdervogne. I vognene må befordres: *Sprit, benzin, eddikesyreanhydrid, alkoholer og estere.*

070 2 081	504081	1959	Falkenberg	5000	9140	26000	19,1	23,1	27,0	12900	TB, RS	Gb	Kh	RIV
070 2 082	504082	"	"	"	"	"	"	"	"	"	"	"	"	"
070 2 083	504083	"	Tjekoslovakiet	4500	8840	24000	19,5	19,5		12000	" S	"	"	"
070 2 084	504084	"	"	"	"	"	"	"		11100	" "	"	"	"
070 2 085	504085	1961	BRNO	"	"	"	19,8	19,9		12200	" "	"	"	"
070 2 086	504086	"	"	"	"	"	19,9	"		12100	" "	"	"	"
070 2 087	504087	"	"	"	"	"	"	"		12000	" "	"	"	"
070 2 088	504088	"	"	"	"	"	"	"		"	" "	"	"	"

Vognejer: **A/S Luxol, Næstved.** Vognen er påmalet ejerens navn.

1 beholdervogn. I vognen befordres: *Tjære, asfalt og brændselolie.*

070 2 101	504101			4000	8600	18700	15,7	15,7		10800	TL, RS	Næ	Kh	RIV
-----------	--------	--	--	------	------	-------	------	------	--	-------	--------	----	----	-----

Nyt nummer	Gl. nummer	Bygningsår	Fabrikationssted	Akselafstand	Længde over puffernes stødflader	Rumindhold	Lastgrænse			Omtrentlig taravægt	Bremse og varme	Hjemsted	Værkstedsområde	Anmærkning
							A	B	C					
							mm	mm	l					

Vognejer: **A/S Dansk Svovlsyre- og Superphosphat-Fabrik, København.** Vognene er påmalet ejerens navn.  
29 beholder- og 4 krukkevogne. I vognene må befordres: *Salpetersyre, saltsyre og svovlsyre.*

040 0 001	508062	1914	Werdau	4200	9200	14000	14,5	14,5	15600	TL, S	Fb	Kh	RIV	Krukkevogn.
040 0 002	508060	1919	Zwischau	4500	9250	12900	13,5	13,5	15300	TB "	"	"	"	"
040 0 003	508053	1940	Scandia	4000	8800	10000	16,5	16,5	15100	TL "	"	"	"	"
040 0 004	508052	"	"	"	"	"	"	"	"	" RS	"	"	"	"
070 8 008	508051	"	"	5000	8100	11000	13,1	13,1	10600	" "	"	"	"	"
070 8 009	508047	1948	"	"	8390	"	"	"	10500	TB "	"	"	"	"
070 8 011	508069	1941	Königsfeld	4500	8800	16000	22,0	22,0	10000	" "	"	"	"	"
070 8 012	508070	"	Rastatt	"	"	"	"	"	9900	" "	"	"	"	"
070 8 021	508061	1962	Scandia	5000	8940	18000	21,2	25,4	10800	" "	"	"	"	"
070 8 031	508044	1949	"	"	8820	16500	19,9	19,9	10500	" "	"	"	"	"
070 8 032	508045	1950	"	"	8900	17500	"	20,4	12100	" "	"	"	"	"
070 8 033	508046	"	"	"	"	"	"	"	"	" "	"	"	"	"
070 8 034	508063	1942	Győr	4500	8800	"	20,0	20,1	12000	" "	"	"	"	"
070 8 035	508064	"	"	"	"	"	"	"	"	" "	"	"	"	"
070 8 036	508065	"	"	"	"	"	"	"	"	" "	"	"	"	"
070 8 037	508054	1941	Belgien	"	8820	"	19,0	19,0	12100	TL "	"	"	"	"



070 8 038	508055	1941	Ungarn	4500	8800	17500	19,4	19,4	11800	TL, RS	Fb	Kh	RIV		
070 8 039	508058	1943	Scandia	"	"	"	19,2	19,2	12000	TB	"	"	"		
070 8 040	508057	1960	Westhofen	"	8740	20000	20,5	22,2	11500	"	"	"	"		
070 8 041	508059	"	"	"	"	"	20,4	"	11600	"	"	"	"		
070 8 061	508066	1941	Saarbrücken	"	8800	12500	21,0	21,5	11000	"	"	"	"		
070 8 062	508067	"	Graz	"	"	"	21,2	"	10800	"	"	"	"		
070 8 063	508068	1940	Heidelberg	"	"	"	21,0	"	11000	TL	"	"	"		
070 8 064	508071	1960	Hameln	"	8740	16000	21,1	25,1 28,0	10900	TB	"	"	"		
070 8 065	508072	"	"	"	"	"	21,0	25,0 "	11000	"	"	"	"		
070 8 066	508073	1961	"	"	"	"	"	" "	"	"	"	"	"		
070 8 067	508074	"	"	"	"	"	"	" "	"	"	"	"	"		
070 8 068	508075	1962	Scandia	5000	8940	16300	19,8	23,8 27,8	11400	"	"	"	"		
070 8 069	508076	"	"	"	"	"	"	" "	11500	"	"	"	"		
070 8 070	508077	"	"	"	"	"	"	" "	12200	"	"	"	"		
070 8 071	508078	"	"	"	"	"	"	" "	"	"	"	"	"		
072 8 072		1966	Hameln	4500	8740	16000	20,9	24,9 28,9	11100	"	"	"	"		A BC
072 8 073		"	"	"	"	"	"	" "	"	"	"	"	"		S-last 20,9 t 24,9 t

Vognejer: **Aktieselskabet Kemisk Industri, København.**

5 beholdervogne. I vognene må befordres: *Asfalt, tjæreprodukter, ammoniakvand, gasvand, tjære, mineralolieprodukter og natronlud.*

070 8 502	502502			3700	7670		14,6	14,6	8600	TL, RS	Ab	Ar	RIV		
070 8 504	502504			4000	8480	14200	15,7	15,7	9200	"	Gb	Kh	"		
070 8 506	502506			4500	8800	20000	18,3	18,9	13700	"	"	"	RIV		
070 8 507	502507			"	"	"	18,4	"	13600	"	"	"	"		
070 8 508	502508	1948	Tatra	"	"	24000	21,1	21,5	10900	TB	"	"	"		

072 2 613-614 se side 226, De danske Spritfabrikker  
072 2 689-700 " " 228, Århus Oliefabrik  
072 8 072-073 " " 233, Dansk Svovlsyre- og Superphosphat-Fabrik  
075 0 832-833 " " 214, Dansk Shell  
075 1 395-405 " " 223, BP Gas

Nyt nummer	Gl. nummer	Bygningsår	Fabrikationssted	Akselafstand	Længde over puffernes stødflader	Rumindhold	Lastgrænse			Omtrentlig taravægt	Brems og varme	Hjemsted	Værkstedsområde	Anmærkning
							A	B	C					
							t							
mm	mm	l												

Vognejer: **A/S Kosangas International, København.**

9 beholdervogne. I vognene må befordres: *Flydende gas med indtil 16,5 atm. tryk ved 50°C. Vognene er påmalet maksimallast for propan, butan samt propylen.*

075 2 016	504016	1943	Dessau	7,2+2m	12700	59800	27,0	27,0	36100	TB, RS	Ar	Ar	RIV
075 2 017	504017	1950	Scandia	"	12690	52000	25,5	25,5	33600	" "	"	"	"
075 2 018	504018	1942	MBA	7,1+2m	13900	62300	27,5	27,5	35900	" " P	"	"	"
075 2 030	504030	1944	Dessau	7,2+2m	12700	62000	27,0	27,0	34900	" "	"	"	"
075 2 031	504031	1943	"	"	"	"	"	"	31900	" "	"	"	"
075 2 032	504032	"	"	"	"	"	"	"	35800	" "	"	"	"
075 2 033	504033	"	"	"	"	"	"	"	34700	" "	"	"	"
075 2 034	504034	1944	"	"	"	"	"	"	34500	" "	"	"	"
075 2 035	504035	1942	Siegen	8,6+2m	14500	52000	24,0	24,0	34400	" "	"	"	"

Vognejer: **Mærsk Raffinaderiet, København S.** Vognene er påmalet ejerens navn.

3 beholdervogne. I vognene må befordres: *Butadin, propan, propylen og butan.*

075 2 061	504061	1958	Scandia	10,0+2m	16640	79300	27,3	35,3	41,3	36700	TB, RS	Gb	Kh	RIV
075 2 062	504062	"	"	"	"	"	"	"	"	" "	"	"	"	
077 2 063	504063	1960	Westhofen	8,7+2m	15700	84200	29,4	37,4	45,4	34600	" "	"	"	" S-last A BC 29,4 37,4

Vognejer: **Nordisk Gulf-Gas A/S, Esbjerg.**

3 beholdervogne. I vognene må befordres: *Butan, butylen, gasblanding A og B, propan og propylen.*

Vognene er påmalet lastgrænser for de forskellige gasarter.

075 2 201	504201	1951	Falkenberg	7,8+2m	13500	49490	28,0	28,0	30100	TB, RS	Es	Ar	RIV
075 2 202	504202	"	"	"	"	"	"	"	30300	" "	"	"	"
077 2 203	504203	1964	"	8,3+2m	14890	79900	28,4	36,4	42,3	35600	" "	"	" S-last A BC 28,4 t 36,6 t

077 2 063 se denne side Mærsk Raffinaderiet

078 5 695-698 se side 228 Århus Oliefabrik

Vognejer: **A/S De forenede Isværker, Esbjerg.** Vognene er påmalet ejerens navn.  
I kølevogn. I vognen må befordres: *Is crème.*

080 0 449	99449	1919	Scandia	4500	9220	14,5	11,0	11,0	13000	TB, RS, L	Es ny H	Ar	RIV hvidmalet
-----------	-------	------	---------	------	------	------	------	------	-------	-----------	---------	----	---------------

DSB vogn  
IKL 24714

Nyt nummer	Gl. nummer	Bygningsår	Fabrikationssted	Akselafstand	Længde over puffernes stødflader	Bundflade	Lastgrænse			Omtrentlig taravægt	Bremse og varme	Hjemsted	Værkstedsområde	Anmærkning
							A	B	C					
				mm	mm	m <sup>2</sup>	t			kg				

Vognejer: **Carlsberg Bryggerierne, København.** Vognene er påmalet »Carlsberg Øl«.  
 124 lukkede vogne. I vognene må beforders: Øl og mineralvand.

081 5 001	99301	1951	Scandia	6000	9260	20,3	19,5	19,5	11400	TB, RS	Gb	Kh	hvidmalet
081 5 002	99302	"	"	"	"	"	"	"	"	"	"	"	"
081 5 003	99303	"	"	"	"	"	"	"	"	"	"	"	"
081 5 004	99304	"	"	"	"	"	"	"	11500	"	"	"	"
081 5 005	99305	"	"	"	"	"	"	"	"	"	"	"	"
081 5 006	99306	"	"	"	"	"	"	"	11400	"	"	"	"
081 5 007	99307	"	"	"	"	"	"	"	11300	"	"	"	"
081 5 008	99308	"	"	"	"	"	"	"	11400	"	"	"	"
081 5 009	99309	"	"	"	"	"	"	"	"	"	"	"	"
081 5 010	99310	"	"	"	"	"	"	"	"	"	"	"	"
081 5 011	99311	"	"	"	"	"	"	"	"	"	"	"	"
081 5 012	99312	"	"	"	"	"	"	"	11600	"	"	"	"
081 5 013	99313	1953	"	"	"	"	"	"	"	"	"	"	"
081 5 014	99314	"	"	"	"	"	"	"	"	"	"	"	"
081 5 015	99315	"	"	"	"	"	"	"	"	"	"	"	"
081 5 016	99316	"	"	"	"	"	"	"	"	"	"	"	"
081 5 017	99317	1954	"	"	"	"	20,0	20,0	11700	"	"	"	"
081 5 018	99318	"	"	"	"	"	"	"	"	"	"	"	"
081 5 019	99319	"	"	"	"	"	"	"	"	"	"	"	"
081 5 020	99320	"	"	"	"	"	"	"	"	"	"	"	"
081 5 021	99321	"	"	"	"	"	"	"	"	"	"	"	"
081 5 022	99322	"	"	"	"	"	"	"	"	"	"	"	"

081 5 028	99328	1959	Scandia	5600	9210	20,3	19,0	19,0	11900	TB, RS	Gb	Kh	hvidmalet
081 5 029	99329	"	"	"	"	"	"	"	"	" "	"	"	"
081 5 030	99330	"	"	"	"	"	"	"	"	" "	"	"	"
081 5 031	99331	"	"	"	"	"	"	"	"	" "	"	"	"
081 5 032	99332	"	"	"	"	"	"	"	"	" "	"	"	"
081 5 033	99333	"	"	"	"	"	"	"	"	" "	"	"	"
081 5 034	99334	"	"	"	"	"	"	"	"	" "	"	"	"
081 5 035	99335	"	"	"	"	"	"	"	"	" "	"	"	"
081 5 036	99336	1960	"	"	"	"	"	"	"	" "	"	"	"
081 5 037	99337	"	"	"	"	"	"	"	"	" "	"	"	"
081 5 055	99455	1949	"	6000	9260	"	19,5	19,5	11200	" "	"	"	"
081 5 056	99456	"	"	"	"	"	"	"	11100	" "	"	"	"
081 5 057	99457	"	"	"	"	"	"	"	11200	" "	"	"	"
081 5 058	99458	"	"	"	"	"	"	"	11500	" "	"	"	"
081 5 059	99459	"	"	"	"	"	"	"	11000	" "	"	"	"
081 5 060	99460	"	"	"	"	"	"	"	11100	" "	"	"	"
081 5 061	99461	"	"	"	"	"	"	"	11200	" "	"	"	"
081 5 062	99462	"	"	"	"	"	"	"	11300	" "	"	"	"
081 5 063	99463	"	"	"	"	"	"	"	11100	" "	"	"	"
081 5 064	99464	"	"	"	"	"	"	"	"	" "	"	"	"
081 5 065	99465	1948	"	"	"	"	"	"	11300	" "	"	"	"
081 5 066	99466	"	"	"	"	"	"	"	11200	" "	"	"	"
081 5 067	99467	"	"	"	"	"	"	"	11300	" "	"	"	"
081 5 068	99468	"	"	"	"	"	"	"	11100	" "	"	"	"
081 5 069	99469	"	"	"	"	"	"	"	11200	" "	"	"	"
081 5 070	99470	"	"	"	"	"	"	"	"	" "	"	"	"
081 5 071	99471	"	"	"	"	"	"	"	11300	" "	"	"	"
081 5 072	99472	"	"	"	"	"	"	"	"	" "	"	"	"
081 5 073	99473	"	"	"	"	"	"	"	"	" "	"	"	"
081 5 074	99474	"	"	"	"	"	"	"	"	" "	"	"	"
081 5 075	99475	"	"	"	9290	"	"	"	11200	" "	"	"	"
081 5 076	99476	"	"	"	"	"	"	"	"	" "	"	"	"
081 5 077	99477	"	"	"	"	"	"	"	11100	" "	"	"	"
081 5 078	99478	"	"	"	"	"	"	"	11300	" "	"	"	"
081 5 079	99479	"	"	"	"	"	"	"	11200	" "	"	"	"

Nyt nummer	Gl. nummer	Bygningsår	Fabrikationssted	Akselafstand	Længde over puffernes stødflader	Bundflade	Lastgrænse			Omtrentlig taravægt	Bremse og varme	Hjemsted	Værkstedsområde	Anmærkning
							A	B	C					
							t							
mm	mm	m <sup>2</sup>				kg								
081 5 080	99480	1948	Scandia	6000	9290	20,3	19,5	19,5	11200	TB, RS	Gb	Kh	hvidmalet	
081 5 081	99481	"	"	"	"	"	"	"	11100	" "	"	"	"	
081 5 082	99482	"	"	"	"	"	"	"	11200	" "	"	"	"	
081 5 083	99483	"	"	"	"	"	"	"	"	" "	"	"	"	
081 5 084	99484	"	"	"	"	"	"	"	"	" "	"	"	"	
081 5 085	99485	1947	"	"	9260	"	"	"	10900	" "	"	"	"	
081 5 086	99486	"	"	"	"	"	"	"	"	" "	"	"	"	
081 5 087	99487	"	"	"	"	"	"	"	11000	" "	"	"	"	
081 5 088	99488	"	"	"	"	"	"	"	10900	" "	"	"	"	
081 5 089	99489	"	"	"	"	"	"	"	11000	" "	"	"	"	
081 5 090	99490	1946	"	"	"	"	"	"	"	" "	"	"	"	
081 5 091	99491	"	"	"	"	"	"	"	11100	" "	"	"	"	
081 5 092	99492	"	"	"	"	"	"	"	11200	" "	"	"	"	
081 5 093	99493	"	"	"	"	"	"	"	11100	" "	"	"	"	
081 5 094	99494	"	"	"	"	"	"	"	11000	" "	"	"	"	
081 5 095	99495	1918	"	4500	8240	16,1	14,0	14,0	9500	TL	"	"	"	
081 5 096	99496	"	"	"	"	"	"	"	9600	" "	"	"	"	
081 5 097	99497	1916	"	"	"	"	"	"	9400	" "	"	"	"	
081 5 116	99516	1890	"	3660	8110	15,8	13,5	13,5	8700	" H	"	"	"	
081 5 126	99526	1898	"	"	"	14,8	"	"	"	" RS	"	"	"	
081 5 136	99536	1939	"	4600	8670	16,9	11,0	11,0	11200	TB "	"	"	"	
081 5 137	99537	1940	"	4500	8240	18,2	16,5	16,5	9600	" H	"	"	"	
081 5 138	99538	"	"	"	"	"	"	"	9800	" "	"	"	"	
081 5 139	99539	"	"	"	"	"	"	"	9900	" "	"	"	"	
081 5 140	99540	"	"	"	"	"	"	"	9800	" "	"	"	"	
081 5 141	99541	"	"	"	"	"	"	"	"	" "	"	"	"	
081 5 142	99542	1942	"	"	8310	"	"	"	"	" "	"	"	"	
081 5 143	99543	"	"	"	"	"	"	"	"	" "	"	"	"	
081 5 144	99544	"	"	"	"	"	15,0	15,0	"	" "	"	"	"	

081 5 145	99545	1903	Scandia	4200	8340	15,2	14,5	14,5	8600	TL, RS	Gb	Kh	hvidmalet				
081 5 146	99546	"	"	"	"	"	"	"	"	" S	"	"	"				
081 5 148	99548	1901	"	"	"	"	"	"	9600	" RS	"	"	"				
081 5 149	99549	"	"	"	"	"	13,5	13,5	9700	" "	"	"	"				
081 5 152	99552	1919	Wisnar	4500	9600	19,9	14,5	14,5	10900	TB "	"	"	"				
081 5 153	99553	"	"	"	"	19,7	"	"	10800	TL "	"	"	"				
081 5 154	99554	"	"	"	"	"	13,5	13,5	"	TB "	"	"	"				
081 5 155	99555	"	"	"	"	"	"	"	11100	TL "	"	"	"				
081 5 156	99556	"	"	"	"	"	14,5	14,5	10900	" "	"	"	"				
081 5 157	99557	"	"	"	"	"	"	"	11000	TB "	"	"	"				
081 5 158	99558	"	"	"	"	"	"	"	11700	" "	"	"	"				
081 5 159	99559	"	"	"	"	"	"	"	10700	" "	"	"	"				
081 5 160	99560	"	"	"	"	"	"	"	11000	" "	"	"	"				
081 5 223	500323	1956	Scandia	5600	9210	20,3	19,5	19,5	11700	" "	"	"	"	RIV			
081 5 224	500324	"	"	"	"	"	"	"	"	" "	"	"	"	"			
081 5 225	500325	"	"	"	"	"	"	"	"	" "	"	"	"	"			
081 5 226	500326	"	"	"	"	"	"	"	"	" "	"	"	"	"			
081 5 227	500327	"	"	"	"	"	"	"	"	" "	"	"	"	"			
081 5 238	500338	1962	"	"	"	20,2	20,0	20,0	11900	" "	"	"	"	"			
081 5 239	500339	"	"	"	"	"	"	"	"	" "	"	"	"	"			
081 5 240	500340	"	"	"	"	"	"	"	"	" "	"	"	"	"			
081 5 241	500341	"	"	"	"	"	"	"	"	" "	"	"	"	"			
081 5 242	500342	"	"	"	"	"	"	"	"	" "	"	"	"	"			
081 5 243	500343	"	"	"	"	"	"	"	"	" "	"	"	"	"			
081 5 244	500344	"	"	"	"	"	"	"	"	" "	"	"	"	"			
081 5 245	500345	"	"	"	"	"	"	"	"	" "	"	"	"	"			
081 5 246	500346	"	"	"	"	"	"	"	"	" "	"	"	"	"			
081 5 247	500347	"	"	"	"	"	"	"	"	" "	"	"	"	"			
083 5 248		1966	"	7100	13000	31,1	17,0	21,0	25,0	15000	" "	"	"	"	S-last	A	BC
083 5 249		"	"	"	"	"	"	"	"	"	"	"	"	"	"	17,0 t	21,0 t
083 5 250		"	"	"	"	"	"	"	"	"	"	"	"	"	"	"	"
083 5 251		"	"	"	"	"	"	"	"	"	"	"	"	"	"	"	"
083 5 252		"	"	"	"	"	"	"	"	"	"	"	"	"	"	"	"
083 5 253		"	"	"	"	"	"	"	"	"	"	"	"	"	"	"	"
083 5 254		"	"	"	"	"	"	"	"	"	"	"	"	"	"	"	"
083 5 255		"	"	"	"	"	"	"	"	"	"	"	"	"	"	"	"
083 5 256		"	"	"	"	"	"	"	"	"	"	"	"	"	"	"	"
083 5 257		"	"	"	"	"	"	"	"	"	"	"	"	"	"	"	"

Nyt nummer	Gl. nummer	Bygningsår	Fabrikationssted	Akselafstand	Længde over puffernes stødflader	Bundflade	Lastgrænse			Omtrentlig taravægt	Bremse og varme	Hjemsted	Værkstedsområde	Anmærkning
							A	B	C					
							t							
mm	mm	m <sup>2</sup>				kg								

Vognejer: **A/S De forenede Bryggerier, København.** Vognene er påmalet »Tuborg«.

72 lukkede vogne. I vognene må befordres: *Mineralvand og øl.*

081 5 582	99582	1906	Maribo	4000	8760	17,7	14,0	14,0	9200	TL, RS	Nø	Kh	hvidmalet
081 5 585	99585	1909	Scandia	"	8740	17,1	11,0	11,0	10200	" "	Hl	"	"
081 5 593	99593	1919	Bautzen	"	8400	16,7	"	"	9500	" S	Nø	"	"
081 5 594	99594	"	"	"	"	"	"	"	9900	" RS	"	"	"
081 5 596	99596	"	"	"	"	"	"	"	10800	TB "	"	"	"



081 5 598	99598	1919	Bautzen	4000	8400	16,7	11,5	11,5	10300	TL, S	Nø	Kh	hvidmalet
081 5 599	99599	"	"	"	"	"	"	"	9700	" RS	"	"	"
081 5 600	99600	"	"	"	"	"	"	"	10800	" "	"	"	"
081 5 601	99601	1929	Scandia	4600	8670	17,0	"	"	9400	" "	Hl	"	"
081 5 602	99602	"	"	"	"	"	"	"	9300	" S	"	"	"
081 5 603	99603	"	"	"	"	"	11,0	11,0	10000	" "	"	"	"
081 5 604	99604	"	"	"	"	"	11,5	11,5	9500	" RS	"	"	"
081 5 605	99605	"	"	"	"	"	"	"	9600	TB S	"	"	"
081 5 606	99606	"	"	"	"	"	"	"	9900	" "	"	"	"
081 5 607	99607	1930	"	"	"	"	"	"	9800	" "	"	"	"
081 5 608	99608	1937	"	"	"	"	11,0	11,0	"	" RS	"	"	"
081 5 609	99609	1940	"	4500	8240	"	16,5	16,5	10000	" H	"	"	"
081 5 610	99610	"	"	"	"	"	"	"	9300	TL "	"	"	"
081 5 611	99611	"	"	"	"	"	"	"	9100	" "	"	"	"
081 5 612	99612	1942	"	"	"	"	"	"	9400	TB "	"	"	"
081 5 613	99613	"	"	"	"	"	"	"	8600	TL "	"	"	"
081 5 614	99614	"	"	"	8310	"	"	"	8700	" "	"	"	"
081 5 615	99615	1916	"	"	8240	16,1	"	"	9400	" RS	Nø	"	"
081 5 616	99616	1946	"	6000	9260	20,3	19,5	19,5	11100	TB "	Hl	"	"
081 5 617	99617	"	"	"	"	"	"	"	11200	" "	"	"	"
081 5 618	99618	"	"	"	"	"	"	"	11100	" "	"	"	"
081 5 619	99619	"	"	"	"	"	"	"	"	" "	"	"	"
081 5 620	99620	"	"	"	"	"	"	"	11200	" "	"	"	"
081 5 621	99621	1947	"	"	"	"	"	"	11000	" "	"	"	"
081 5 622	99622	"	"	"	"	"	"	"	"	" "	"	"	"
081 5 623	99623	"	"	"	"	"	"	"	11100	" "	"	"	"
081 5 624	99624	"	"	"	"	"	"	"	"	" "	"	"	"
081 5 625	99625	"	"	"	"	"	"	"	"	" "	"	"	"
081 5 626	99626	1948	"	"	"	"	"	"	11200	" "	"	"	"
081 5 627	99627	"	"	"	"	"	"	"	"	" "	"	"	"
081 5 628	99628	"	"	"	"	"	"	"	"	" "	"	"	"
081 5 629	99629	"	"	"	"	"	"	"	11300	" "	"	"	"
081 5 630	99630	"	"	"	"	"	"	"	11200	" "	"	"	"
081 5 631	99631	"	"	"	"	"	"	"	"	" "	"	"	"
081 5 632	99632	"	"	"	"	"	"	"	"	" "	"	"	"
081 5 633	99633	"	"	"	"	"	"	"	"	" "	"	"	"
081 5 634	99634	"	"	"	"	"	"	"	"	" "	"	"	"
081 5 635	99635	"	"	"	"	"	"	"	"	" "	"	"	"

Nyt nummer	Gl. nummer	Bygningsår	Fabrikationssted	Akselafstand	Længde over puffernes stødflader	Bundflade	Lastgrænse			Omtrentlig taravægt	Bremse og varme	Hjemsted	Værkstedsområde	Anmærkning
							A	B	C					
							mm	mm	m <sup>2</sup>					
081 5 636	99636	1951	Scandia	6000	9260	20,3	19,5	19,5	11400	TB, RS	Hl	Kh	hvidmalet	
081 5 637	99637	"	"	"	"	"	"	"	11300	" "	"	"	"	
081 5 638	99638	"	"	"	"	"	"	"	11500	" "	"	"	"	
081 5 639	99639	"	"	"	"	"	"	"	11400	" "	"	"	"	
081 5 640	99640	"	"	"	"	"	"	"	11500	" "	"	"	"	
081 5 641	99641	"	"	"	"	"	"	"	11300	" "	"	"	"	
081 5 642	99642	"	"	"	"	"	"	"	11400	" "	"	"	"	
081 5 643	99643	"	"	"	"	"	"	"	11500	" "	"	"	"	
081 5 644	99644	1954	"	"	"	"	20,0	20,0	11700	" "	"	"	"	
081 5 645	99645	"	"	"	"	"	"	"	"	" "	"	"	"	
081 5 646	99646	"	"	"	"	"	"	"	"	" "	"	"	"	
081 5 647	99647	"	"	"	"	"	"	"	"	" "	"	"	"	
081 5 648	99648	"	"	"	"	"	"	"	"	" "	"	"	"	
081 5 649	99649	"	"	"	"	"	"	"	"	" "	"	"	"	
081 5 650	500650	1956	"	5600	9210	"	19,5	19,5	11600	" "	"	"	" RIV	
081 5 651	500651	"	"	"	"	"	"	"	11700	" "	"	"	"	
081 5 652	500652	"	"	"	"	"	"	"	"	" "	"	"	"	
081 5 653	500653	"	"	"	"	"	"	"	"	" "	"	"	"	
081 5 654	500654	"	"	"	"	"	"	"	"	" "	"	"	"	
081 5 655	500655	1963	"	7600	13520	32,6	18,5	22,5	26,5	13200	" "	"	"	
081 5 656	500656	"	"	"	"	"	"	"	"	" "	"	"	"	
081 5 657	500657	"	"	"	"	"	"	"	"	" "	"	"	"	
081 5 658	500658	"	"	"	"	"	"	"	13300	" "	"	"	"	
081 5 659	500659	"	"	"	"	"	"	"	"	" "	"	"	"	
081 5 660	500660	"	"	"	"	"	"	"	"	" "	"	"	"	
081 5 661	500661	"	"	"	"	"	"	"	"	" "	"	"	"	
081 5 662	500662	"	"	"	"	"	"	"	13200	" "	"	"	"	
081 5 663	500663	"	"	"	"	"	"	"	13300	" "	"	"	"	
081 5 664	500664	"	"	"	"	"	"	"	"	" "	"	"	"	

081 5 905 Se side 226 De danske Spritfabrikker

Vognejer: **Albani Bryggerierne A/S, Odense.** Vognene er påmalet ejerens navn.

7 lukkede vogne. I vognene må befordres: Øl og mineralvand.

081 5 986	081 5 686	1918	Scandia	4500	8640	18,6	15,5	15,5	10500	TB, RS	Od	Ng	hvidmalet
081 5 987	081 5 687	"	"	"	"	"	"	"	"	" "	"	"	"
081 5 988	99688	"	"	"	"	"	"	"	"	" "	"	"	"
081 5 989	99689	"	"	"	"	"	"	"	"	" "	"	"	"
081 5 990	99690	"	"	"	"	"	"	"	"	" "	"	"	"
081 5 994	99694	1925	SFJ	3660	7800	16,0	8,0	8,0	8100	TL H	"	"	"
081 5 995	99695	1926	"	"	"	"	"	"	"	" "	"	"	"

083 5 248-257 Se side 239 Carlsberg Bryggerierne

Nyt nummer	Gl. nummer	Bygningsår	Fabrikationssted	Akselafstand	Længde over puffernes stødflader	Bundflade	Lastgrænse			Omtrentlig taravægt	Bremse og varme	Hjemsted	Værkstedsområde	Anmærkning
							A	B	C					
							t							
				mm	mm	m <sup>2</sup>				kg				

Vognejer: **Novo Terapeutisk Laboratorium A/S**. Vognen er påmalet ejerens navn.

1 maskinkølevogn. I vognen må befordres: *Kirtler samt i indenlandsk færdsel andre letfordærlige varer.*

084 4 401	500401	1943	Scandia	6280	11000	13,4	24,5	25,0	23500	TB,S,P,L	Fb	Kh	RIV S-last	A 24,5	BC 25,0
-----------	--------	------	---------	------	-------	------	------	------	-------	----------	----	----	------------	--------	---------

Vognejer: **Sukkerfabrikken, Nykøbing FI**. Vognene er påmalet ejerens navn.

12 stk., litra Z<sub>N</sub>. I vognene må befordres: *Råsukker*. Vognenes maks. hast. 60 km/t.

500451	1920	Breslau	2x2,15	8550	32000	24,0	24,0	12800	TB	Nf	Kh				
500452	"	"	"	"	"	"	"	12700	"	"	"				
500453	1924	Landskrona	"	8950	"	"	"	10900	"	"	"				
500454	1920	Breslau	"	8550	"	"	"	11400	TL	"	"				
500455	"	"	"	"	"	"	"	"	"	"	"				
500456	"	"	"	"	"	"	"	11500	"	"	"				
500457	"	"	"	"	"	"	"	11400	"	"	"				
500458	"	"	"	"	"	"	"	"	"	"	"				
500459	"	"	"	"	"	"	"	"	"	"	"				
500460	1919	Landskrona	"	"	"	"	"	9800	"	"	"				
500461	"	"	"	"	"	"	"	"	"	"	"				
500462	"	"	"	"	"	"	"	9600	"	"	"				

Vognejer: **Teknologisk Institut, København.**

1 undervisningsvogn.

095 0 961	99961	1934	Frichs-Scandia	20930	1965	Kh	38240	TB, RS	Gb	Kh	Tidl. MP 544
-----------	-------	------	----------------	-------	------	----	-------	--------	----	----	--------------

Vognejer: **Jydsk Teknologisk Institut, Aarhus.**

12 undervisningsvogne.

095 0 985	99985	1934	Frichs-Scandia	20930	1966	Ar	35550	TB RS	Ar	Ar	Tidl. MP 540
095 0 986	99986	1930	Odense	13,8+2,5m 20930	1965	"	28570	" "	"	"	" ML 501
095 0 987	99987	"	"	"	1964	"	28900	" "	"	"	" " 515
095 0 988	99988	1928	Frichs	19010	1963	"	30600	" "	"	"	" MR 531
095 0 989	99989	1929	Odense	13,8+2,5m 20930	1963	"	21000	" "	"	"	" ML 503
095 0 990	99990	1929	"	"	1961	"	27200	" "	"	"	" ML 513
095 0 991	99991	1930	"	"	"	"	28400	" "	"	"	" " 509
095 0 992	99992	"	"	"	1960	"	28000	" "	"	"	" " 510
095 0 993	99993	"	"	"	"	"	28700	" "	"	"	" " 512
095 0 994	99994	1928	Frichs	19010	1958	"	27300	" "	"	"	" MR 532
095 0 995	99995	1930	Odense	13,8+2,5m 20930	"	"	28900	" H	"	"	" ML 514
095 0 996	99996	1928	Frichs	19010	1956	"	34100	" RS	"	"	" MR 533

1944

1945

1946

1947

1948

1949

1944 1945 1946 1947 1948 1949

1944 1945 1946 1947 1948 1949



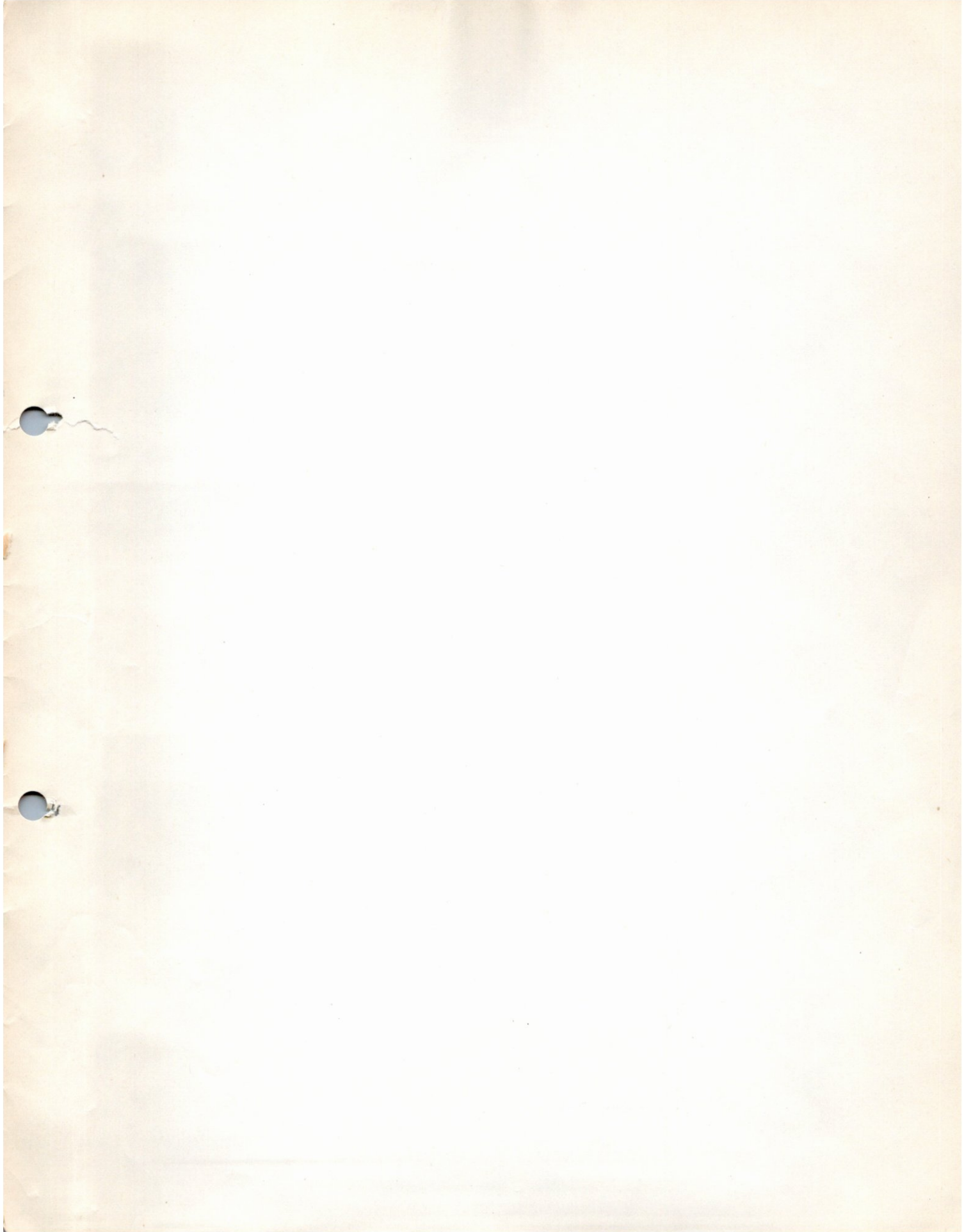







DANSKE STATSBANER

---

Tillæg

til fortegnelsen over

# Driftsmateriellet II

1968

Fortegnelsen består, med dette tillæg, af følgende sider:

1-IV	28a-I	76a-II	92-I	183-I	222-II
2-IVx	28b-I	76c-II	92a-I	184-I	223-II
2c-Ix	28c-I	76e-I	93-I	185-I	224-II
2d-Ix	36-IVx	76g-I	94-I	186-I	225-II
2e-Ix	37-IVx	76i-I	98-I	187-I	226-II
2f-Ix	40-IV	76j-Ix	99-I	188-I	227-II
2g-Ix	41-II	76k-II	100-I	189-I	228-II
3a-I	42-II	76o-I	100a-II	201-II	229-II
3b-I	43-IVx	76r-I	100b-I	203-II	230-II
3c-I	45-VI	76t-I	100c-I	204-II	231-II
4-VIx	46-IV	78c-I	100d-I	205-II	232-II
5-IV	46a-Ix	78d-I	101-II	206-II	233-II
6a-II	47-III	78e-I	102-II	207-II	234-II
7-V	52-Vx	78f-I	103-I	208-II	235-II
8a-II	53-IVx	78g-I	104-I	209-II	236-II
8c-II	54-IVx	78i-I	105-II	210-II	237-II
19-Vx	55-VI	79-V	106-II	211-II	238-II
20-Vx	56-VI	80-IV	107-I	212-II	239-II
21-IIIx	60-IV	80a-II	108-I	213-II	240-II
22-IIIx	61-III	80b-II	108a-II	214-II	241-II
23-IVx	62-III	81-IIIx	108b-II	215-II	242-II
24-IVx	65-III	85-I	108c-I	216-II	243-II
25-III	66-III	87-I	108d-I	217-II	244-II
25b-I	67-III	88-I	109-I	218-II	245-II
27-III	68-III	89-II	117-I	219-II	
27d-I	75-II	90-II	181-I	220-II	
28-III	76-II	91-I	182-I	221-II	

Med dette tillæg følger siderne, der i ovenstående fortegnelse er mærket med x; ialt 22 blade.

Maj 1968





## 76 Benzinperronkarrer.

4 cyl. vandkølet 40—50 hk motor, selvstarter, gearkasse, max. hast. 30—40 km/t,  
 tara ca. 1350 kg, last indtil 200 kg, træk i krogen ca. 500 kg (maks.),  
 karren kan vende på en 4 m platform. Karrerne stationeres, hvor der haves behov for dem.

Nr.	Bygge- år	Leverandør	Statio- nering	Nr.	Bygge- år	Leverandør	Statio- nering	Nr.	Bygge- år	Leverandør	Statio- nering
101	1937	Alfr. Raffel	d 1	130	1947	Hans Hviid	d 1	158	1953-54	Hans Hviid	d 1
102	»	»	»	131	»	»	»	159	»	»	»
103	»	»	»	132	»	»	»	160	»	»	»
				133	»	»	»	161	»	»	»
105	1937	Alfr. Raffel	d 1	134	»	»	»	162	»	»	»
106	»	»	»	135	»	»	d 2	163	»	»	»
107		»	d 2	136	»	»	»	164	»	»	ctv.Kh
108		»	»	137	»	»	»	165	»	»	d 1
109		»	»	138	»	»	»	166	»	»	d 2
110		»	»	139	»	»	»	167	»	»	»
111		»	»	140	1948	»	»	168	»	»	»
112	1939	Hans Hviid	d 1	141	»	»	d 1	169	»	»	»
				142	»	»	»	170	»	»	»
114	1939	Hans Hviid	d 1	143	»	»	»	171	»	»	»
115	»	»	»	144	»	»	»	172	»	»	»
116		»	d 2	145	»	»	»	173	»	»	»
117		»	»	146	1949	»	»	174	»	»	»
118		»	»	147	1948	»	d 2	175	»	»	»
119		»	»	148	»	»	»	176	»	»	»
				149	»	»	»	177	1956	»	d 1
121		Hans Hviid	d 2					178	»	»	ctv. Ar
122		»	»	151	»	»	»	179	»	»	ctv. Kh
123		»	»	152	»	»	»	180	»	»	»
				153	»	»	»	181	»	»	»
				154	»	»	»	182	»	»	»
				155	»	»	»	183	»	»	d 1
				156	1949	»	d 1	501	»	»	»
128			d 2	157	»	»	»	502	»	»	d 2

## 1 Benzinkarre ombygget fra elektrokarre.

Nr. 41.

Byggeår 1940, ombygget af A/S Titan, stationeret ctv. Kh.

### 53 Elektroperronkarrer.

Egenvægt 1200 kg, lasteevne 2000 kg, ladets areal 1200 × 2330 mm,  
højde over jorden 650 mm.

Karrerne stationeres, hvor der haves behov for dem.

Nr.	Bygge- år	Leverandør	Statio- nering	Nr.	Bygge- år	Leverandør	Statio- nering	Nr.	Bygge- år	Leverandør	Statio- nering	
1	1929	A. E. G.	d 2					45	1935	Titan	d 1	
2	1930	»	»	24		Titan	d 1					
3		Siemens	d 1	25		»	d 2	61		Titan	d 1	
				26		»	»	62		»	»	
5		Siemens	d 2	27		»	»	63	} overtaget fra postvesenet 1949	»	»	
6		»	»	28		»	»	64		»	»	
7		A. E. G.	»	29		»	»	65		»	»	
8		Siemens	d 1	30		»	»					
9		»	d 2	31		»	»					
10		»	»					ctv. Kh nr. 1		Titan	ctv. Kh	
11		»	»	33	1936	Titan	d 2	ctv. Kh nr. 2		»	»	
12		»	»	34	»	»	»	ctv. Kh nr. 3		»	»	
13		Titan	d 1	35	»	»	»	ctv. Kh nr. 4		»	»	
14		»	»	36	1935	»	d 1	ctv. Kh nr. 5		»	»	
15		»	»	37	»	»	»	ctv. Kh nr. 5		»	»	
16		»	»	38	1935	»	»					
17		»	»	39	»	»	»					
18		»	»	40	»	»	»					
				41	»	»	»	ctv. Ar nr. 1		Titan	ctv. Ar	
				42	1935	Titan	d 1	ctv. Ar nr. 2		»	»	
21		Titan	d 1	43	»	»	»	ctv. Ar nr. 3		»	»	
22		»	»	44	»	»	»			»	»	

## 38 Gaffeltrucks.

Nr.	Bygge- år	Leverandør	Statio- nering	Nr.	Bygge- år	Leverandør	Statio- nering	Nr.	Bygge- år	Leverandør	Statio- nering
1		Clark yardlift	d 1	15	1951	Clark Klipper	d 1	101		Buda MF 10	d 1
2		»	d 2	16	»	»	d 2	103		»	»
3		»	d 1	17	»	»	d 1	105		»	»
4		»	d 2	18	»	»	d 2	107		»	»
6		»	d 2	19	»	»	d 1	109		»	»
7		»	d 1	20	»	»	d 2	111		»	»
8		»	d 2	21	»	»	d 1	112		»	d 2
9	1951	Clark Klipper	d 1	23	»	»	d 1	113		»	d 1
10	»	»	d 2	24	»	»	d 2	126			d 2
11	»	»	d 1	u. nr.	»	»	ctv.Kh	128			»
12	»	»	d 2	»	»	»	»				
13	»	»	d 1	»		Hyster	»	ctv. Ar nr. 1		Clark Klipper	ctv. Ar
14	»	»	d 2					ctv. Ar nr. 2		Clark yardlift	»
								ctv. Ar nr. 3		Hyster	»

## 1 Larvefodskran.

nr.	byggeår	leverandør	stationering
2	1942	Hans Nielsen, Århus	Århus

Kan arbejde med kulgrab.

## 2 Traktorer.

leverandør	Gummihjul	stationering
Fordson Major Muerhil	»	Havnegården i Århus Esbjerg

## 1 Rangertraktor.

leverandør	Fabrikat	stationeret
A/S Meisner-Jensen	Pulso	Maskindepotet Enghave

## 3 Transportvogne.

Nr.	fabrikat	stationeret
1	Douglas	Gb. emballagepl.
3	»	»
5	»	»

1912

1912

1912

1912

1912

1912

1912

1912

1912

1912

1912

1912

1912

1912

1912

1912

1912

1912

1912

1912

1912





## SPECIALVOGNE

De i fortegnelsen anvendte forkortelser er:

**TB** = Trykluftbremse

**TL** = Trykluftledning

**RS** = Rangerskruebremse

**S** = Skruebremse

**H** = Håndbremse

**P** = Nødbremseindretning

**L** = Varmeledning

**O** = Brændeovn

**EL-stik** = EL-stikkontakt til byens net



## 27 Snepløve nr. 1—28 \*)

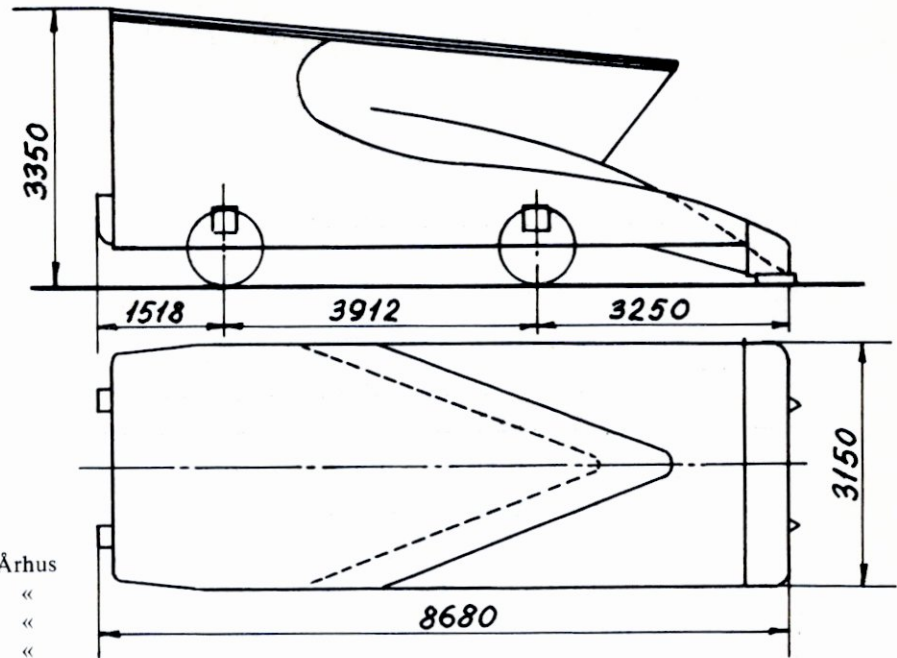

- 1—3. 1867 Århus  
 4—7. 1868 «  
 8—10. 1869 «  
 11—13. 1871 «  
 14—16. 1872 «  
 17—25. 1875 Randers  
 27—28. 1877 Scandia

Nr. 7 er forsynet med 3  
 lodrette sneskær, et i  
 hver side og et i midten.

Vægt tjenstf. 12500 kg

## 19 Snepløve nr. 29—47

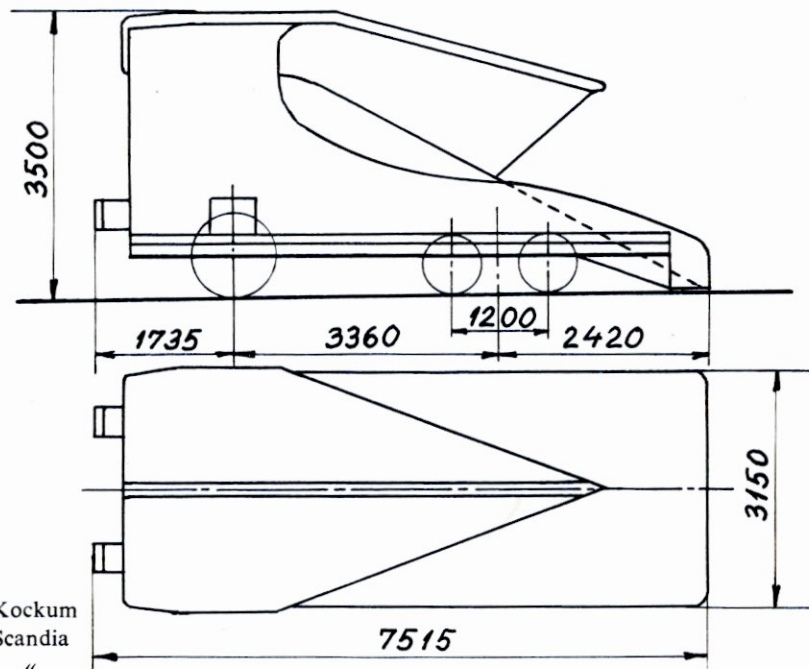

- 29—34. 1882 Kockum  
 35—36. 1883 Scandia  
 37—38. 1891 «  
 39—40. 1886 Skabo  
 41. 1896 Scandia  
 42—45. 1898 «  
 46—47. 1900 «

Nr. 32, 46 og 47 er særligt ind-  
 rettet til snerydning på  
 dobbeltspor  
 Nr. 34 og 43 er forsynet med 3  
 lodrette sneskær, et i hver  
 side og et i midten

Vægt tjenstf. 12000 kg

## 20 Snepløve nr. 48, 51—71 \*)

\*) Udrangeret er nr.  
55, 59.

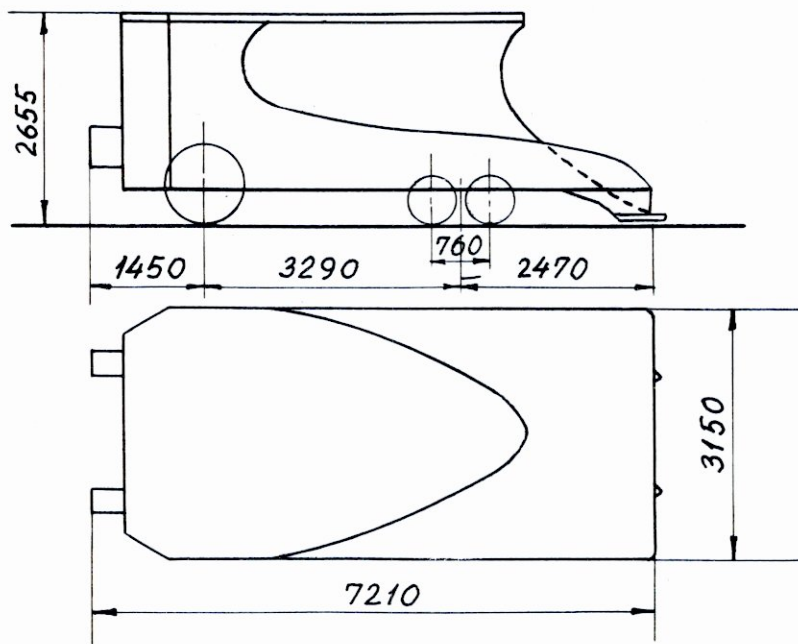

51—52. 1877 Scandia  
53—57. 1879 «  
58—60. 1888 «  
61—62. 1891 «  
63—64. 1905 «  
65—66. 1910 «  
67. 1912 «  
68. 1914 «  
69—71. 1920 «

Nr. 60—71  
må kun bruges på baner med skinner  
på 32 kg eller derover

51—58. Vægt tjenstf. 12000 kg  
60—71. « « 16500 «

## 3 Snepløve nr. 72, 74, 75

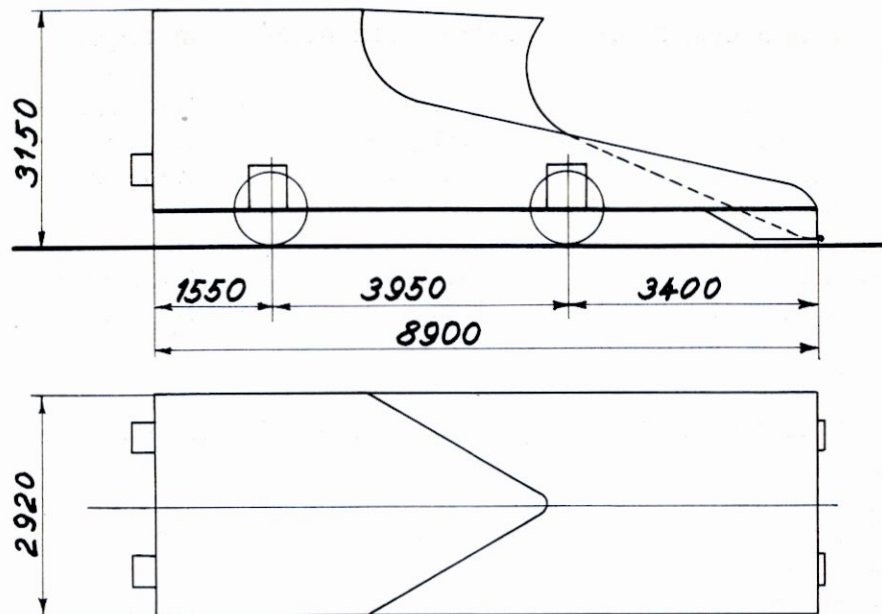

Nr. 72. 1916 S. F. J.  
 Nr. 74, 75. 1910 «

Vægt tjenstf.: Nr. 72: 10200 kg  
 Nr. 74: 12900 «  
 Nr. 75: 12700 «

## 1 Snepløve nr. 73

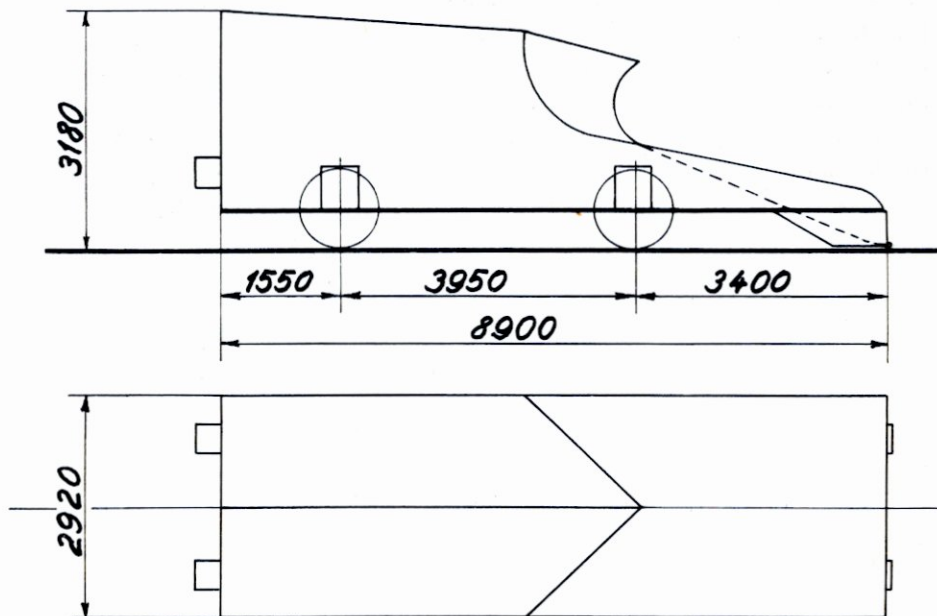

1882 Scandia

Vægt tjenstf. 11500 kg

**I 1ste distrikt er snepløvene stationerede som følger:**

Nr.	Nr.	Nr.
32. Næstved.	43. Slagelse.	62. København H.
37. Slagelse.	44. Nykøbing Fl.	63. Roskilde.
38. Gedser.	46. København Gb.	64. Roskilde.
39. Næstved.	47. « Kh.	65. Ringsted.
40. Helsingør.	48. « L.	66. Helsingør.
41. Korsør.	60. Frederikssund.	71. Kalundborg.
42. Kalundborg.	61. København H.	98. Næstved.

**I 2det distrikt er snepløvene stationerede som følger:**

Nr.	Nr.	Nr.
1. Fredericia.	18. Esbjerg.	45. Tønder H.
2. Struer.	19. Århus H.	51. Viborg.
3. Skern.	20. Bramminge.	52. Skive H.
4. Esbjerg.	21. Ålborg.	53. Hobro.
5. Sønderborg.	22. Lunderskov.	54. Brande.
6. Frederikshavn.	23. Langå.	56. Thisted.
7. Århus Ø.	24. Randers.	57. Langå.
8. Struer.	25. Nyborg.	58. Viborg.
9. Ringkøbing.	27. Ryomgård.	67. Fredericia
10. Tønder H.	28. Ålborg.	68. Brande.
11. Århus H.	29. Sønderborg.	69. Horsens.
12. Skanderborg.	30. Haderslev.	70. Brande.
13. Randers.	31. Fredericia.	72. Odense syd.
14. Struer.	33. Assens.	73. « «
15. Brande.	34. Viborg.	74. Svendborg.
16. Bramminge.	35. Herning.	75. Nyborg.
17. Lunderskov.	36. Padborg.	99. Ålborg.

## 2 Snepløve nr. 72, 74

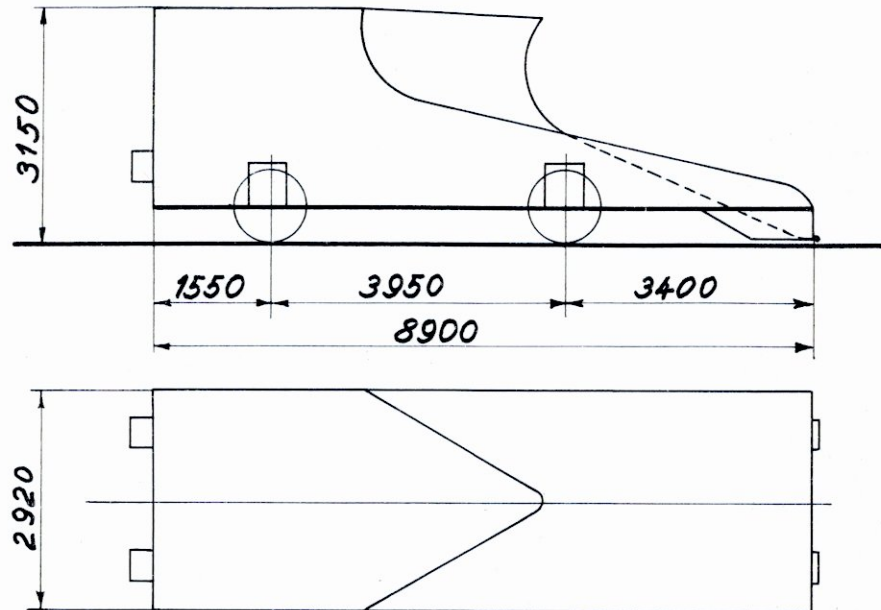

Nr. 72. 1916 S.F.J.  
Nr. 74. 1910 »

Vægt tjenstf.: Nr. 72: 10200 kg  
Nr. 74: 12900 »

**I 1. distrikt er snepløvene stationeret som følger:**

Nr.	Nr.	Nr.
37. Slagelse.	65. Ringsted.	104. København H.
40. Helsingør.	71. Kalundborg.	105. Ballerup.
44. Nykøbing Fl.	98. Næstved.	106. Slagelse.
47. København Kh.	101. Roskilde.	107. Næstved.
48. København L.	102. Kalundborg.	108. Roskilde.
61. København H.	103. Rødby Færge.	109. I reserve.

**I 2. distrikt er snepløvene stationeret som følger:**

Nr.	Nr.	Nr.
6. Frederikshavn.	24. Randers.	56. Struer.
7. Århus Ø.	25. Nyborg.	57. Langå.
9. Ringkøbing.	28. Ålborg.	58. Viborg.
11. Århus H.	30. Haderslev.	67. Fredericia.
12. Skanderborg.	31. Fredericia.	69. Horsens.
13. Randers.	34. Viborg.	70. Brande.
17. Lunderskov.	35. Herning.	72. Odense syd.
18. Esbjerg.	36. Padborg.	74. Svendborg.
19. Århus H.	45. Tønder H.	99. Ålborg.
21. Ålborg.	51. Viborg.	
22. Lunderskov.	52. Brande.	



## 2 Snepløve nr. 98, 99

Værkstedssområde } nr. 98: Kh  
 } nr. 99: Ar

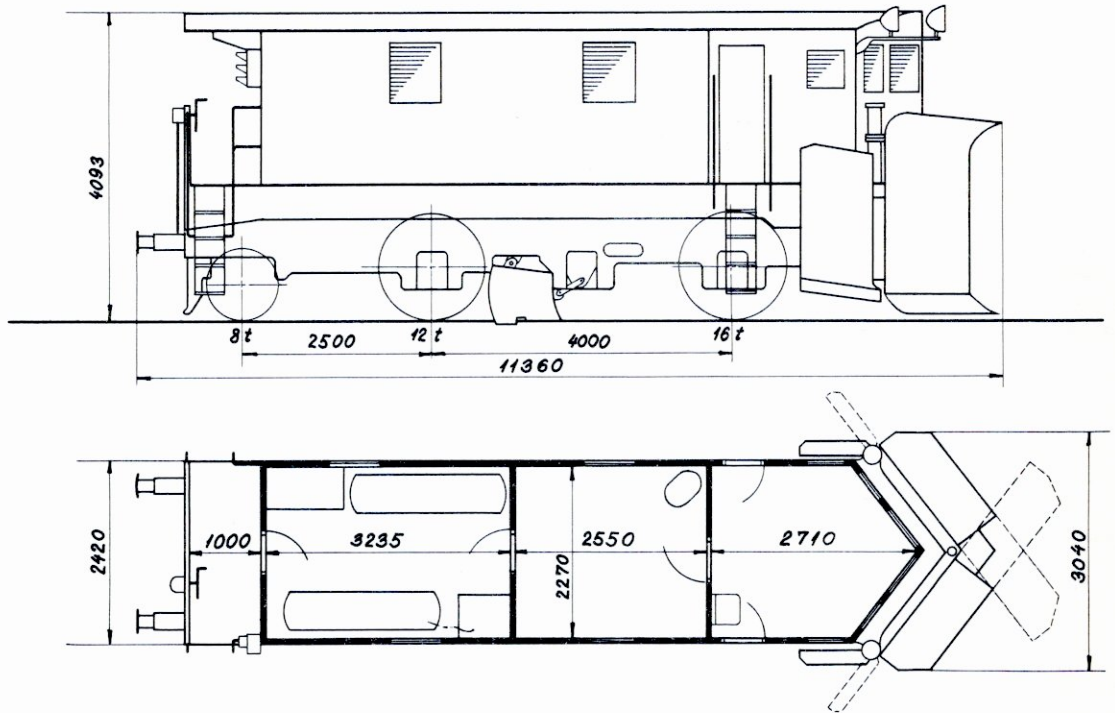

1957 Århus

Nr. 98. Hjemsted: Næstved  
 Nr. 99. « Ålborg  
 Kakkelovn  
 Dynamoanlæg, spænding 24 volt,  
 til plovens egenbelysning

Tjenstf. vægt 36000 kg  
 Trykluftbremse  
 Skruebremse

## 2 Udrykningsbiler

Værkstedssområde } 1 stk. i Kh  
 } 1 stk. i Ar

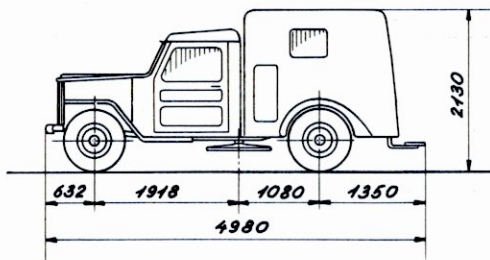

1956 Willys Overland

Benzinmotor 72 hk  
 4-hjuls hyd. bremse  
 2- « mek. «

Tara ca. 1950 kg  
 Last 850 kg  
 Højest 3 passagerer

## 1 Påhængsvogn for udrykningsbiler

Værkstedssområde: Ar

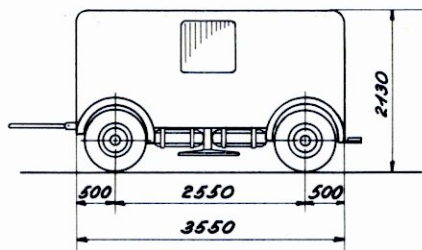

1956 Åbenrå

Mekanisk standbremse  
 Vakuumbremse

Tara ca. 800 kg  
 Last 2600 kg

# 1 Sneplø nr. 101

Værkstedsområde: Kh.

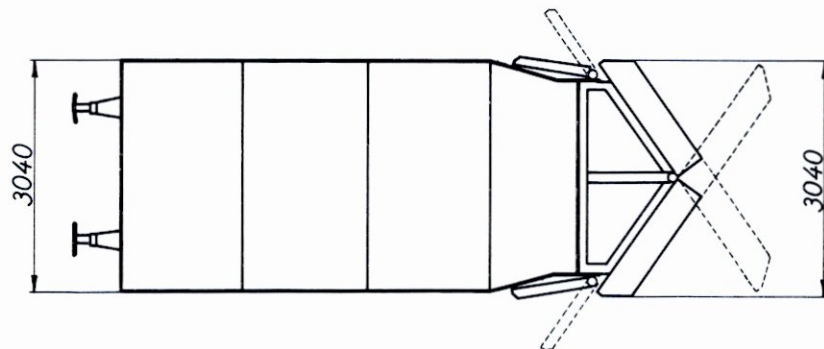
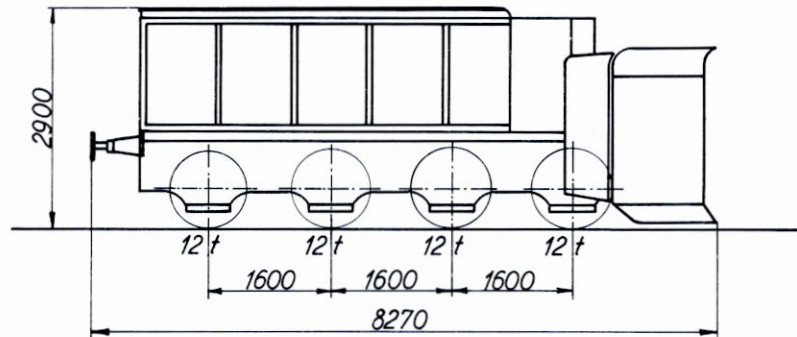

1908 Linden  
Ombygget 1964 København

Hjemsted: Roskilde

Tjenstf. vægt 47000 kg

100-100



## 12 Hjælpevogn nr. 1-12

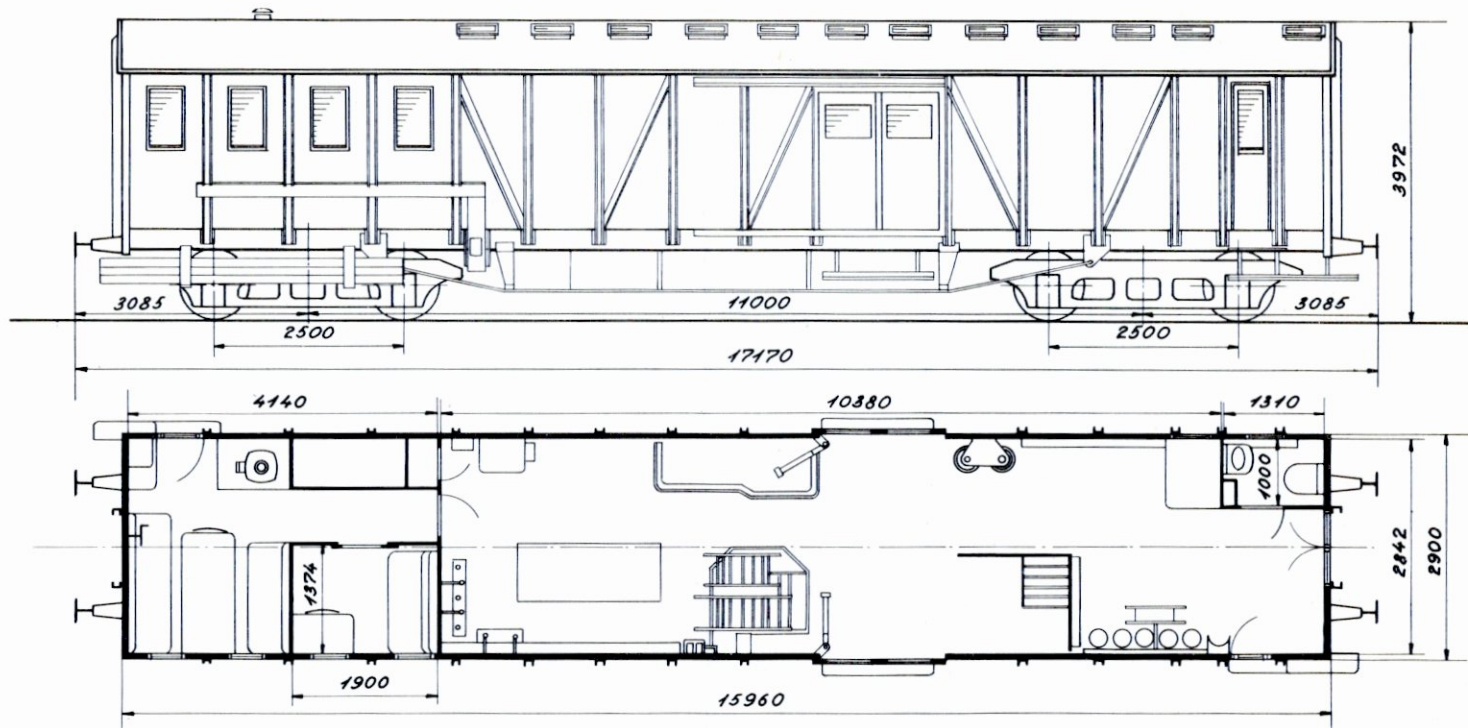

Nr. 7, 10. Scandia 1903  
 øvrige Scandia 1907  
 Ombygget 1954-55  
 København

	Hjemsted :	Værkstedsmr. :
Nr. 1.	København	København
« 2.	«	«
« 3.	Korsør	«
« 4.	Næstved	«
« 5.	Nyborg	Aarhus
« 6.	Fredericia	«
« 7.	Padborg	«
« 8.	Esbjerg	«
« 9.	Aarhus	«
« 10.	Aalborg	«
« 11.	Struer	«
« 12.	Reserve i Kh	København

Gasbelysning  
 Højtryksvarmeanlæg  
 Kakkellov  
 Tørkloset  
 Håndvask

Tjenestfærdig vægt 43000 kg  
 Trykluftbremse (G-P)  
 Nødbremse  
 Skruebremse

## 4 Hjælpevogne 101, 102, 103, 104

Værkstedsområde: Kh 101—102

« Ar 103—104

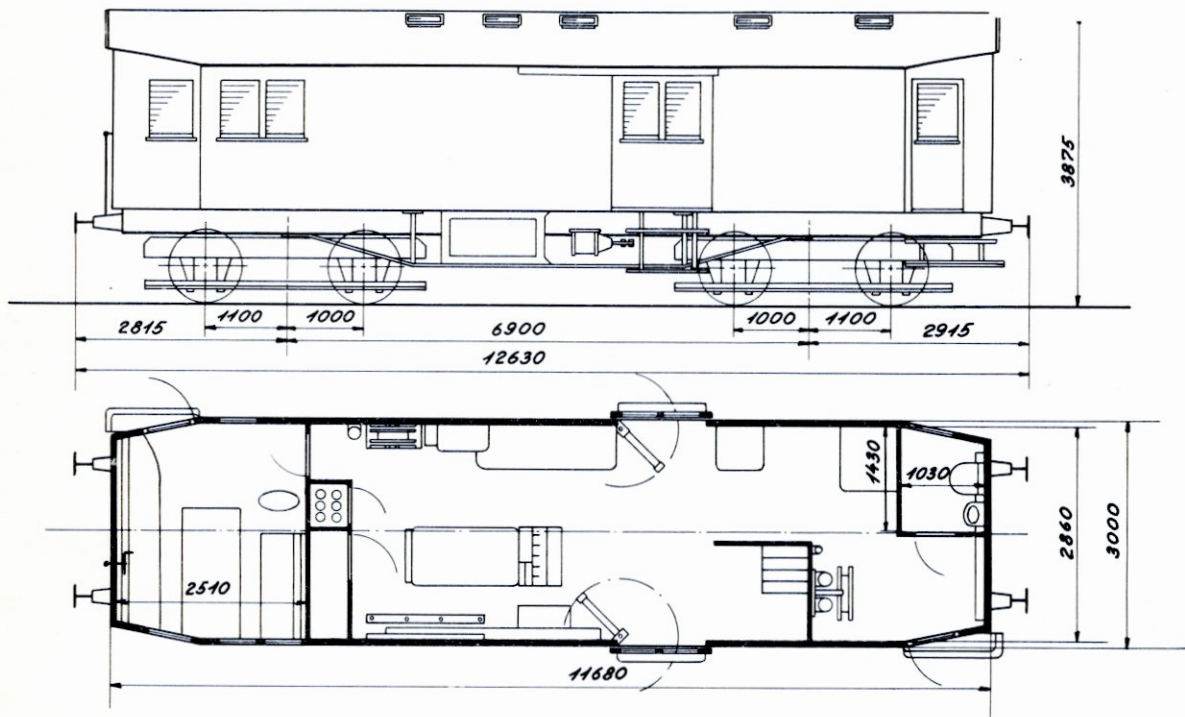

1927 Scandia  
Ombygget 1955 København

Gasbelysning  
Højtryksvarmeapparater  
Kakkelovn  
Tørkloset

Tjenstf. vægt ca. 28000 kg  
Nødbremse  
Varmeledning  
Skruebremse

## Hjemsted:

Nr. 101 Roskilde  
« 102 Næstved  
« 103 Randers  
« 104 Brande

## 2 Hjælpevogne A nr. 7, 9

Værkstedsområde: Ar

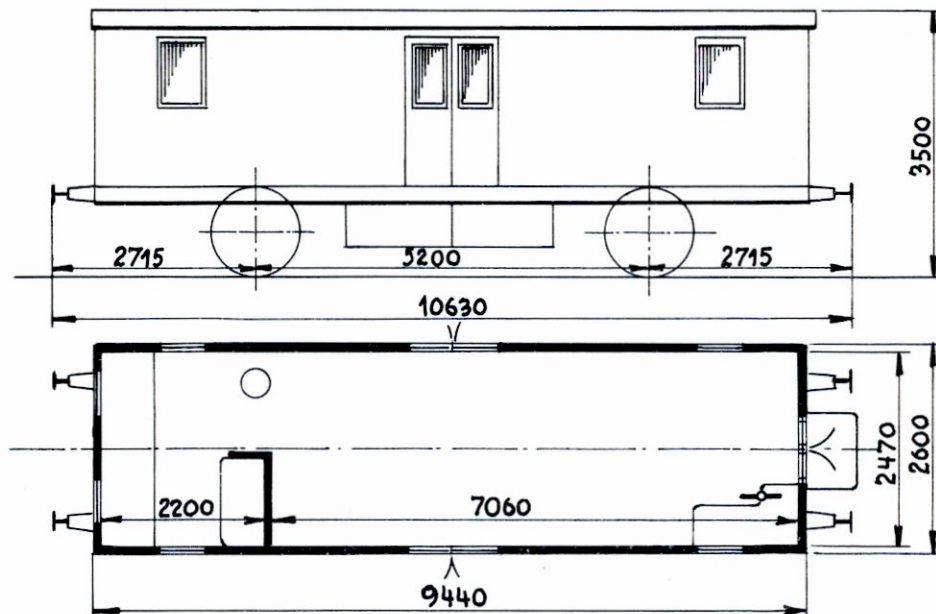

7. 1911 Scandia  
9. 1917 «

Petroleumslamper  
Højtryksvarmeapparater  
Kakkelovne

Tjenstf. vægt 19700 kg  
Trykluftbremse (P)  
Nødbremseindretninger  
Skruebremse

Hjemsted:

7. »Ålborg«  
9. »Brand«

## 2 Hjælpevogne C nr. 18, 20

Værkstedsområde: Ar

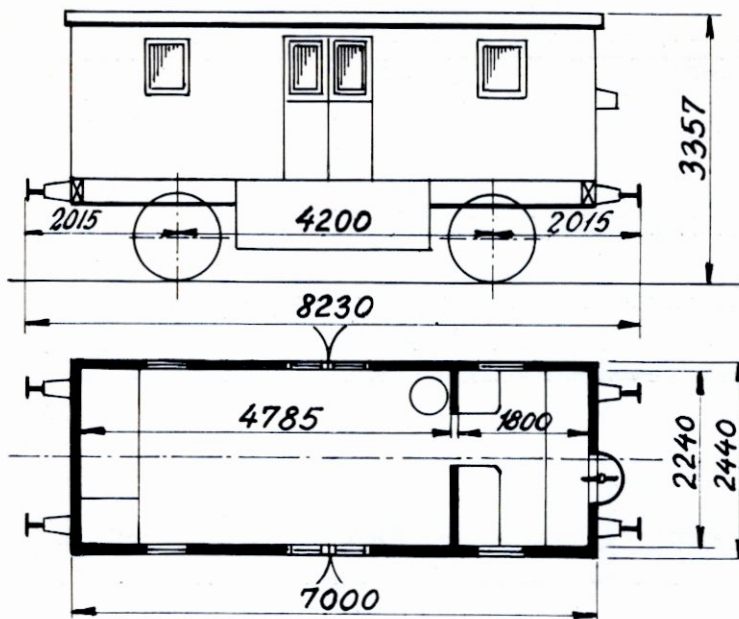

1880 Breslau  
Ombygget 1925 København

Petroleumslamper  
Højtryksvarmeapparater  
Kakkelovne

Tjenstf. vægt 12000 kg  
Trykluftledning  
Nødbremseindretninger  
Skruebremse

Hjemsted:

Nr. 18. »Frederikshavn«

Nr. 20. »Viborg«





## 2 Kørekraner nr. 141—142

Værkstedsområde } nr. 141 Ar  
 } nr. 142 Kh

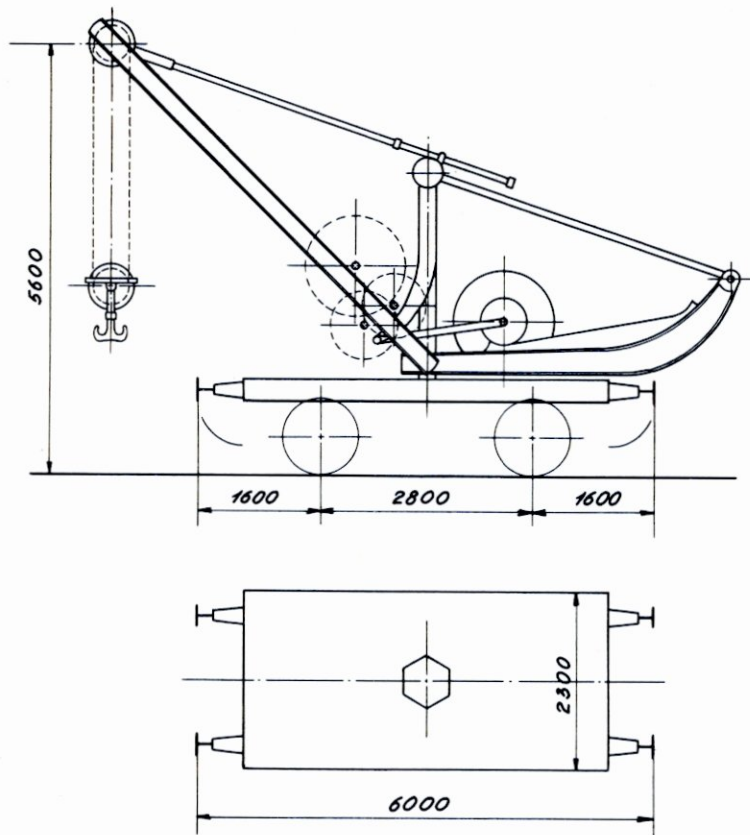

141. 1879 Bruchsal  
 142. 1880 «

Hjemsted:  
 Nr. 141. Centralværkstedet, Århus  
 « 142. « København

Løftehøjde 4600 mm  
 Bæreevne 10000 kg  
 141. Tara ca. 19500 kg  
 142. « 18550 kg

## 1 Kørekran nr. 143

Værkstedsområde: Kh

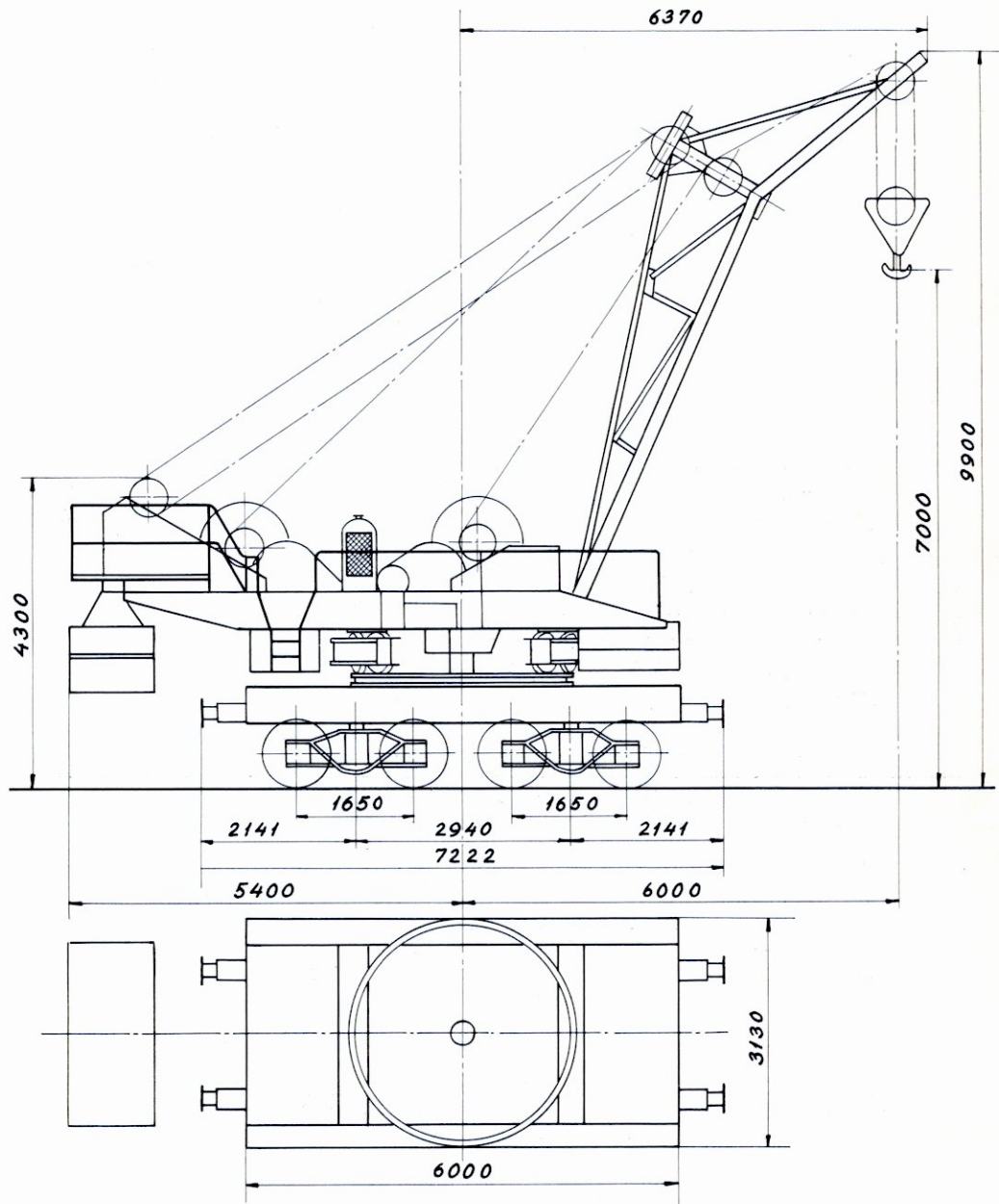

1934 Scandia-Titan

Hjemsted:  
Københavns Godsbanegård

Løftehøjde 7000 mm  
 Bæreevne 30000 kg  
 ved 6000 mm udliggerradius  
 Tjenstf. vægt  
 i kørestilling ca. 61900 kg  
 Rangerskruebremse

# I Kørekran nr. 144

Værkstedssområde: Ar

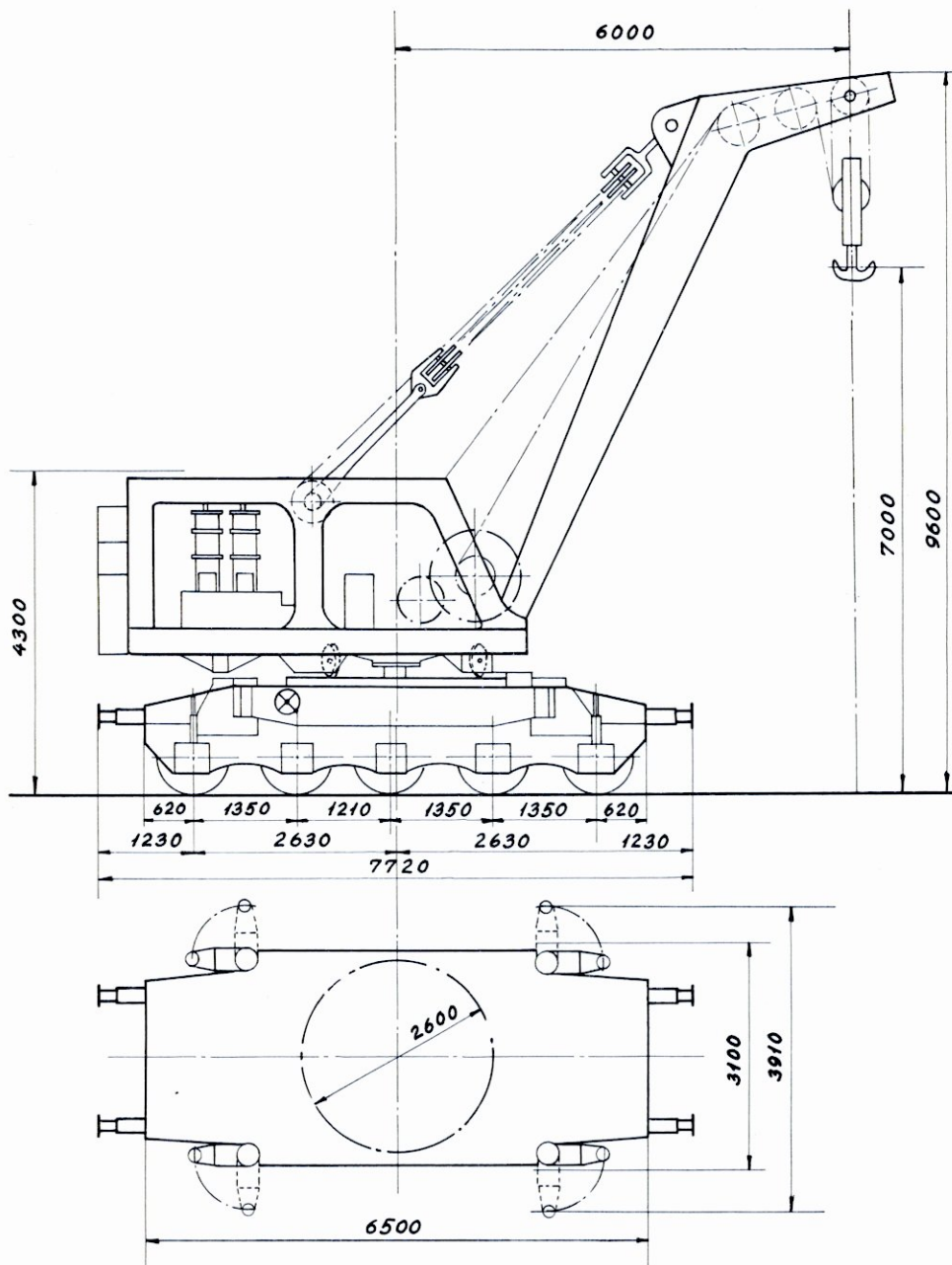

1937 Vølund

Hjemsted: »Århus H«

Løftehøjde 7000 mm  
 Bæreevne 30000 kg ved  
 6000 mm udliggerradius  
 Tjenstf. vægt i kørestilling  
 ca. 67000 kg  
 Rangerskruebremse  
 Trykluftledning  
 Varmeledning

## I Skinneudlægningskran nr. 155

Værkstedsområde: Kh.

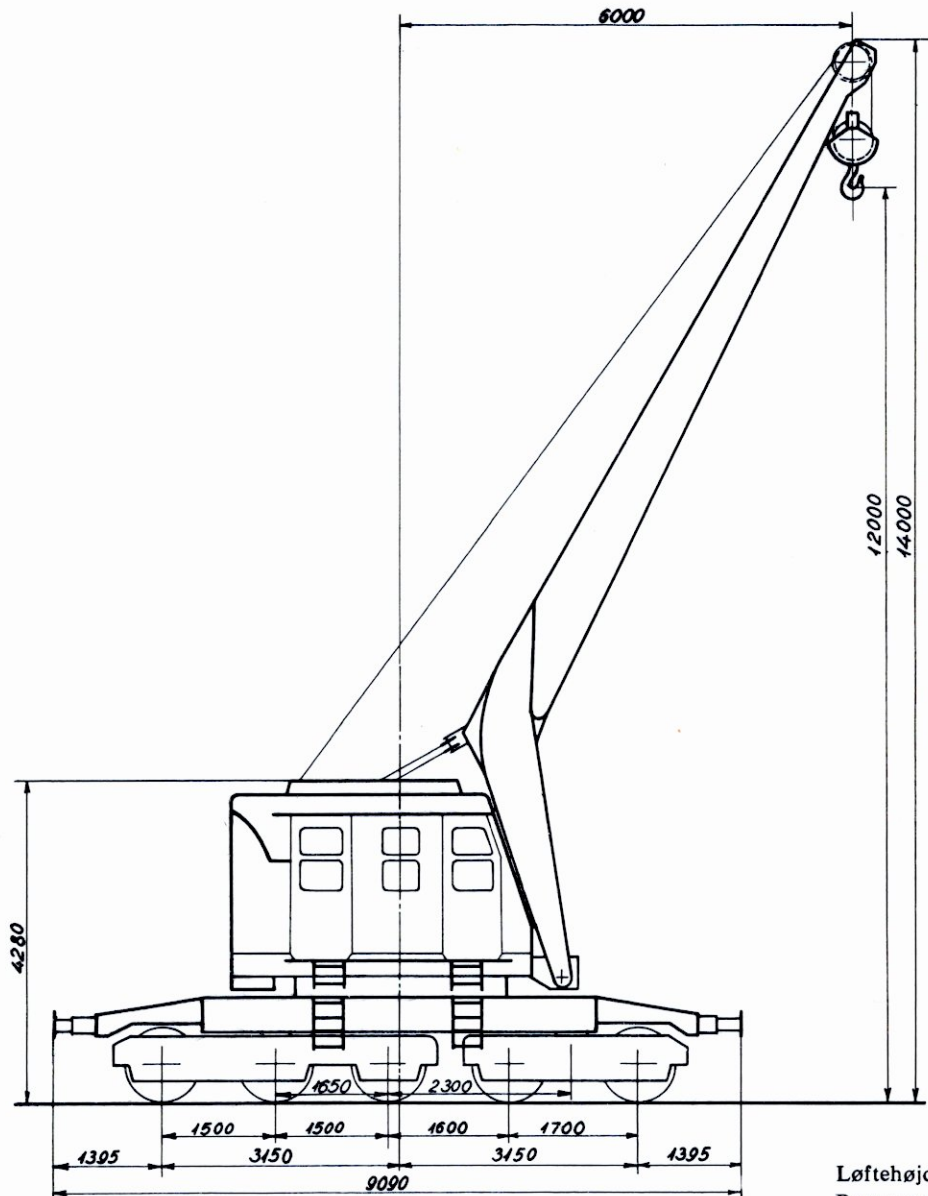

Løftehøjde 12000 mm  
 Bæreevne 15000 kg ved  
 6000 mm udliggerradius.  
 Tjenestefærdig vægt  
 ca. 82 800 kg.  
 Rangerskruebremse.  
 Trykluftbremse.

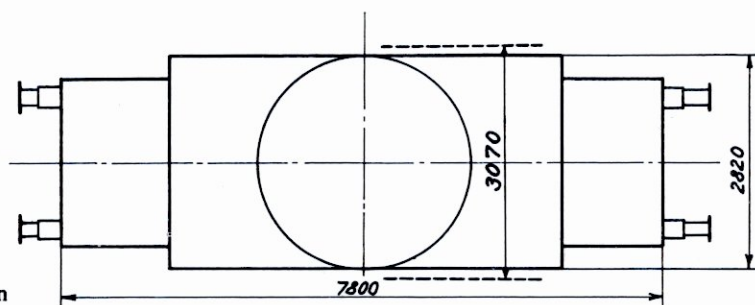

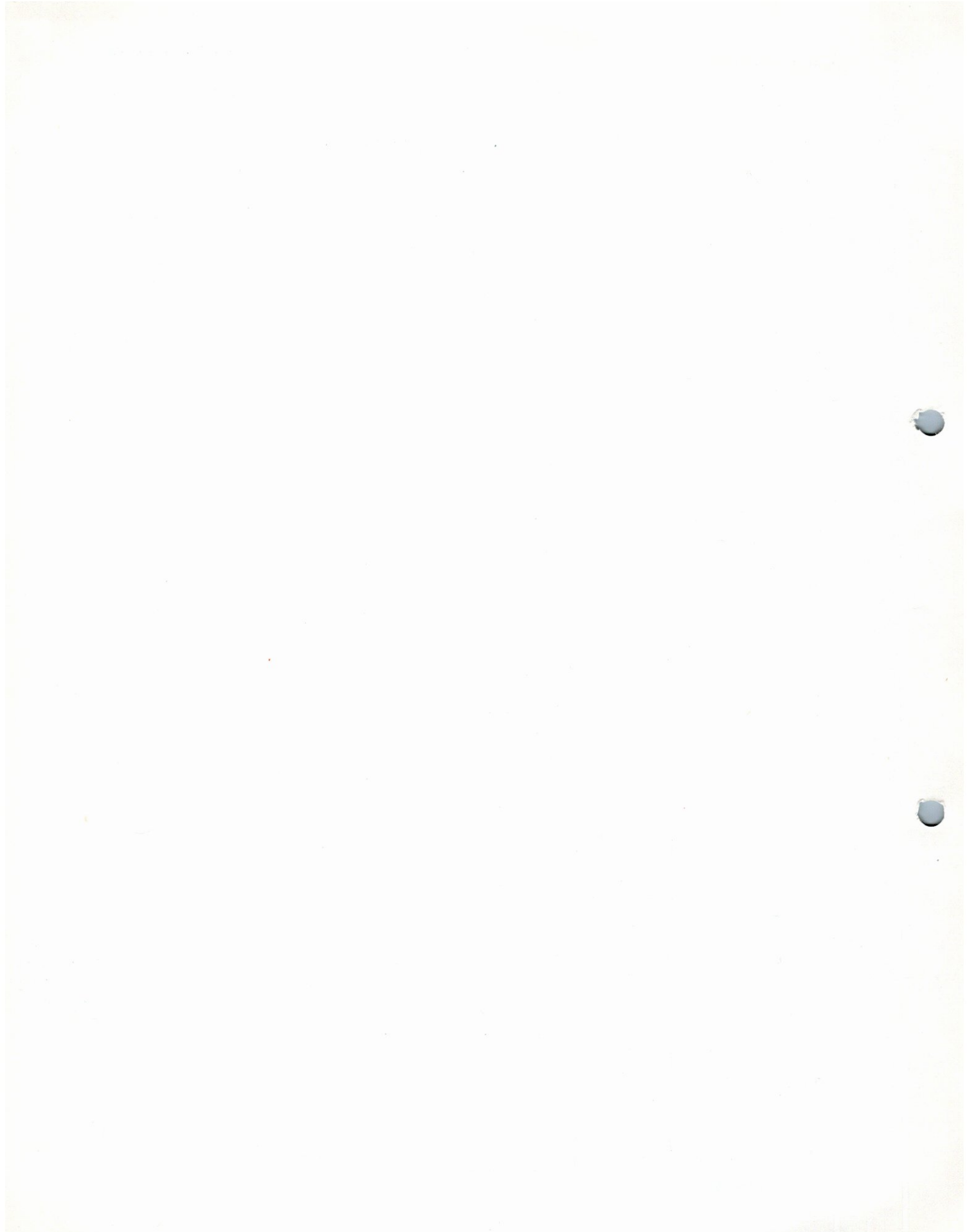

## 2 Kørekraner nr. 145-146

Kørekraner

Kørekran nr. 145: hjemsted Gb  
 Kørekran nr. 146: hjemsted Fa  
 Befordringshastighed i tog:  
 maks. 80 km/t  
 Mindste kurveradius 90 m  
 Kranmotor:  
 Deutz diesel F/A 8L714  
 2 gear for selvkøring:  
 1. gear ca 40 m/min  
 2. gear ca 90 m/min  
 Lysanlæg:  
 dynamo 1000 watt 24 volt  
 Kranmanøvrering:  
 trykluft system Westinghouse  
 Puffere drejelige  
 Understøtning i arbejdsstilling:  
 enten 4 stk ydre eller 4 stk  
 indre hydrauliske donkrafte

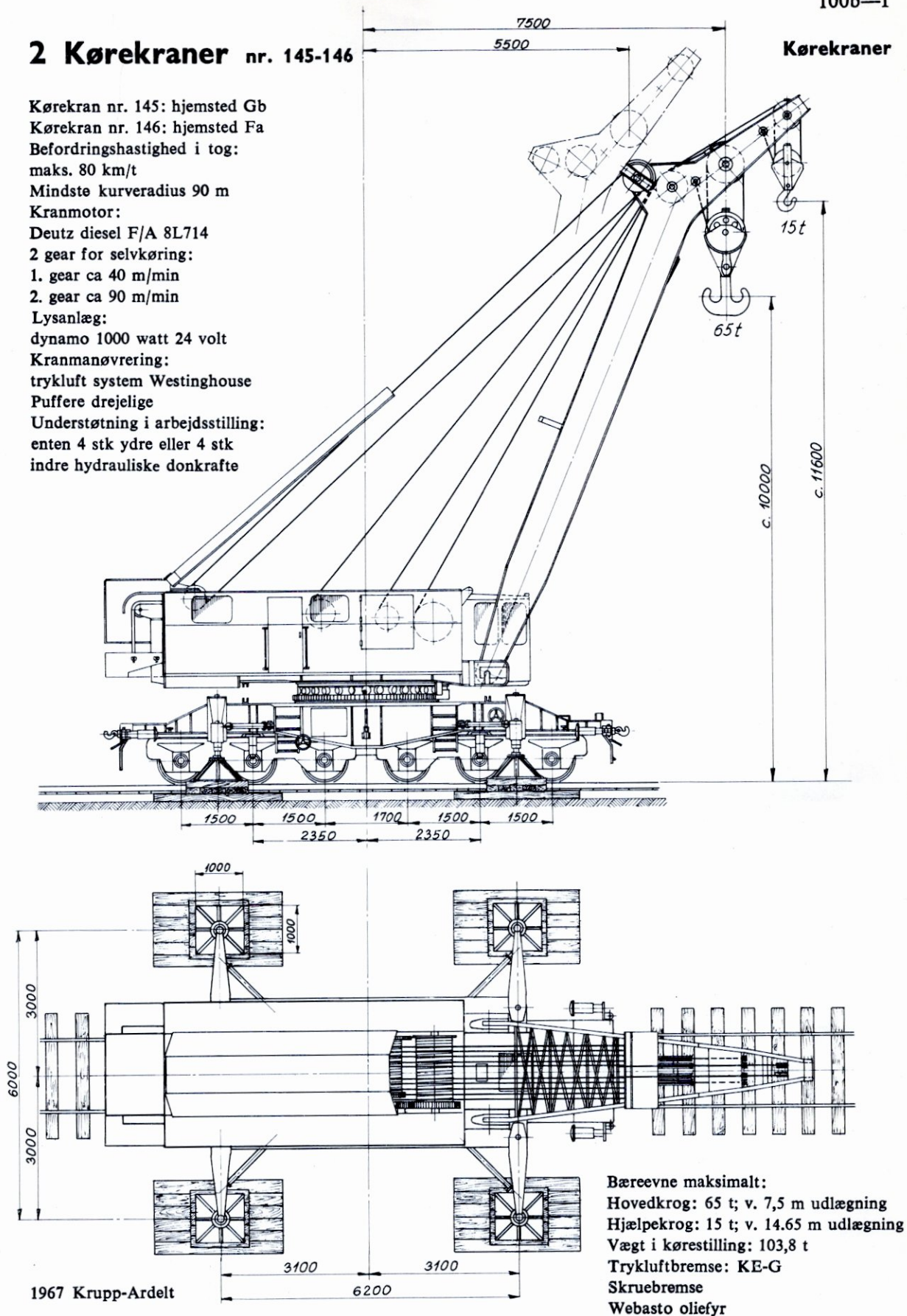

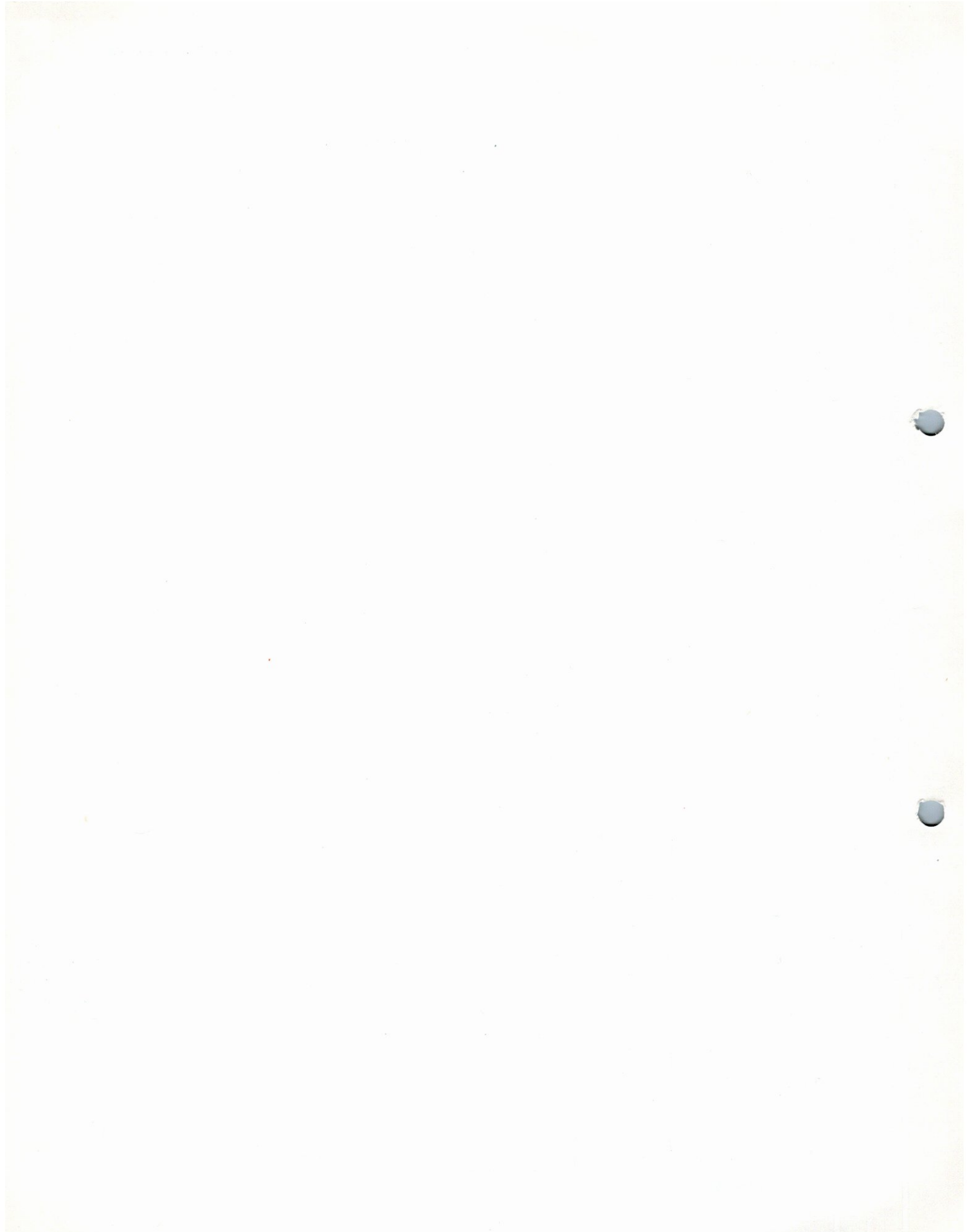



Samlingstegn af  
Værkstedsvogn 425 og 426  
Kørekran nr. 145 og 146  
Løbevogn nr. 438 og 439

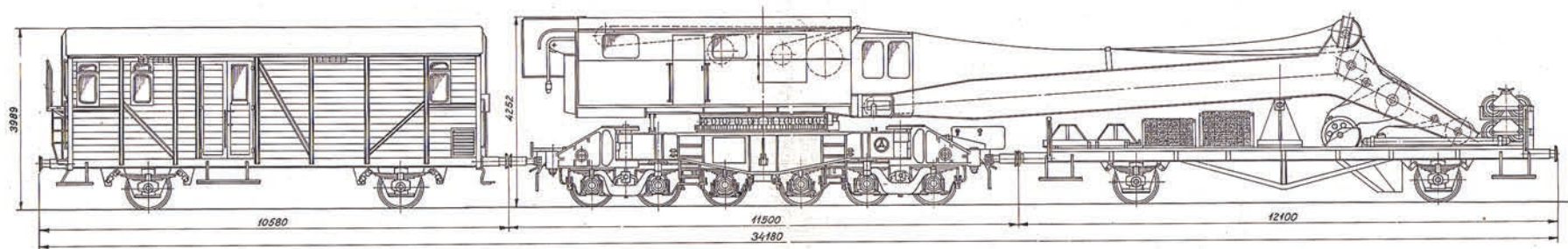

**I Skinneudlægningskran nr. 155**

Hjemsted: Kh.

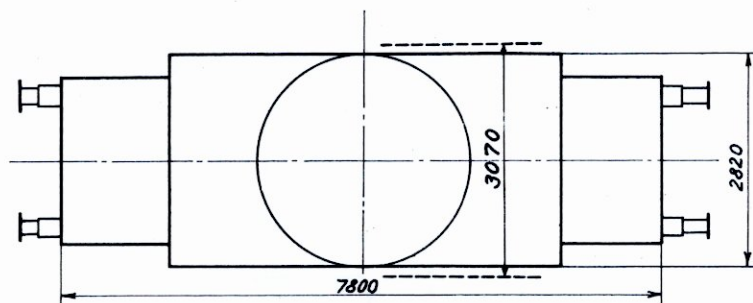
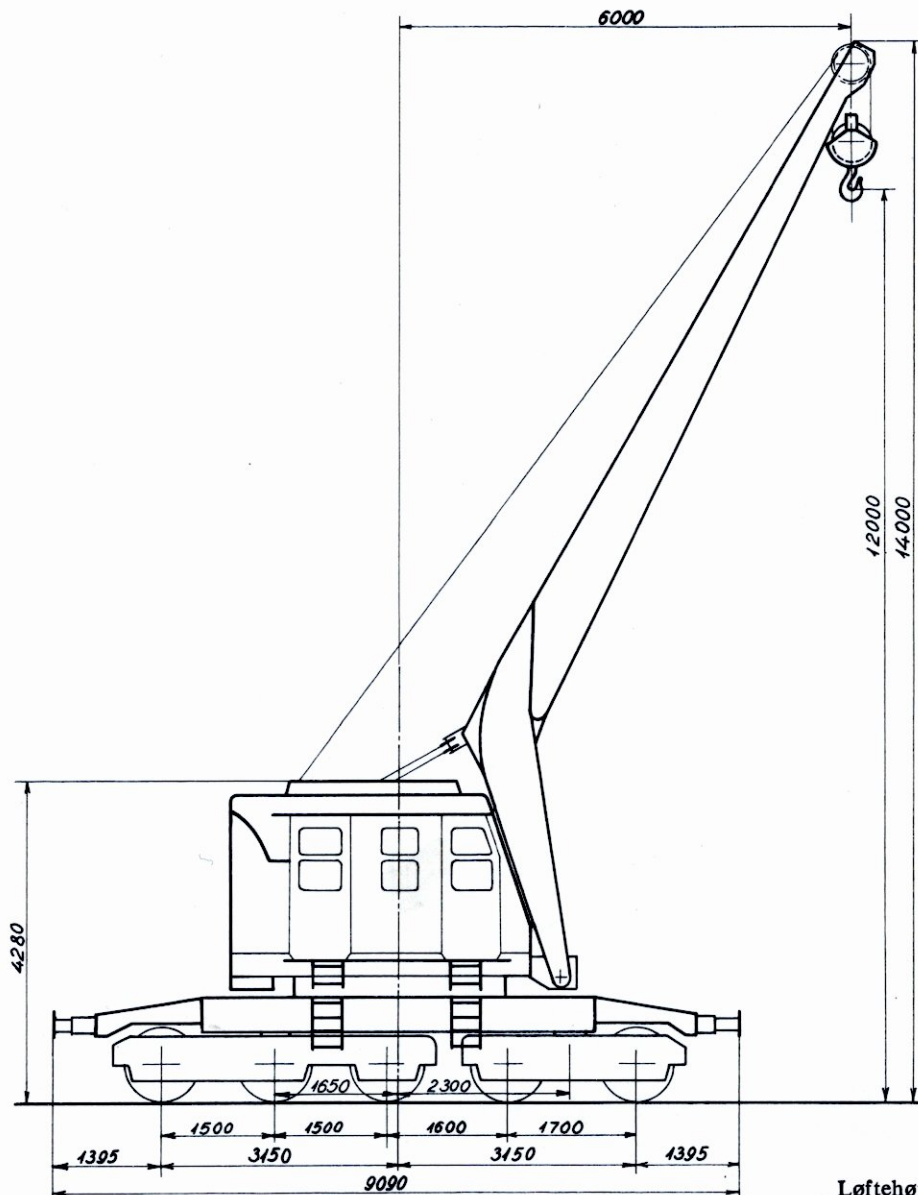

Løftehøjde 12 m  
 Bæreevne: 15 t ved  
 6 m udliggerradius  
 Tjenestefærdig vægt  
 ca. 82 800 kg.  
 Rangerskruebremse  
 Trykluftbremse  
 Befordringshastig i tog  
 80 km/t

## 2 Skinneudlægningskraner nr. 156-157

Hjemsted; nr. 156 Ar

Hjemsted; nr. 157 Kh

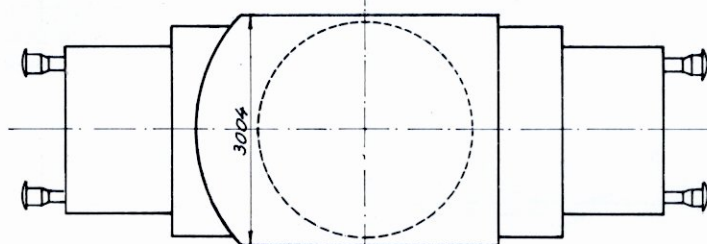
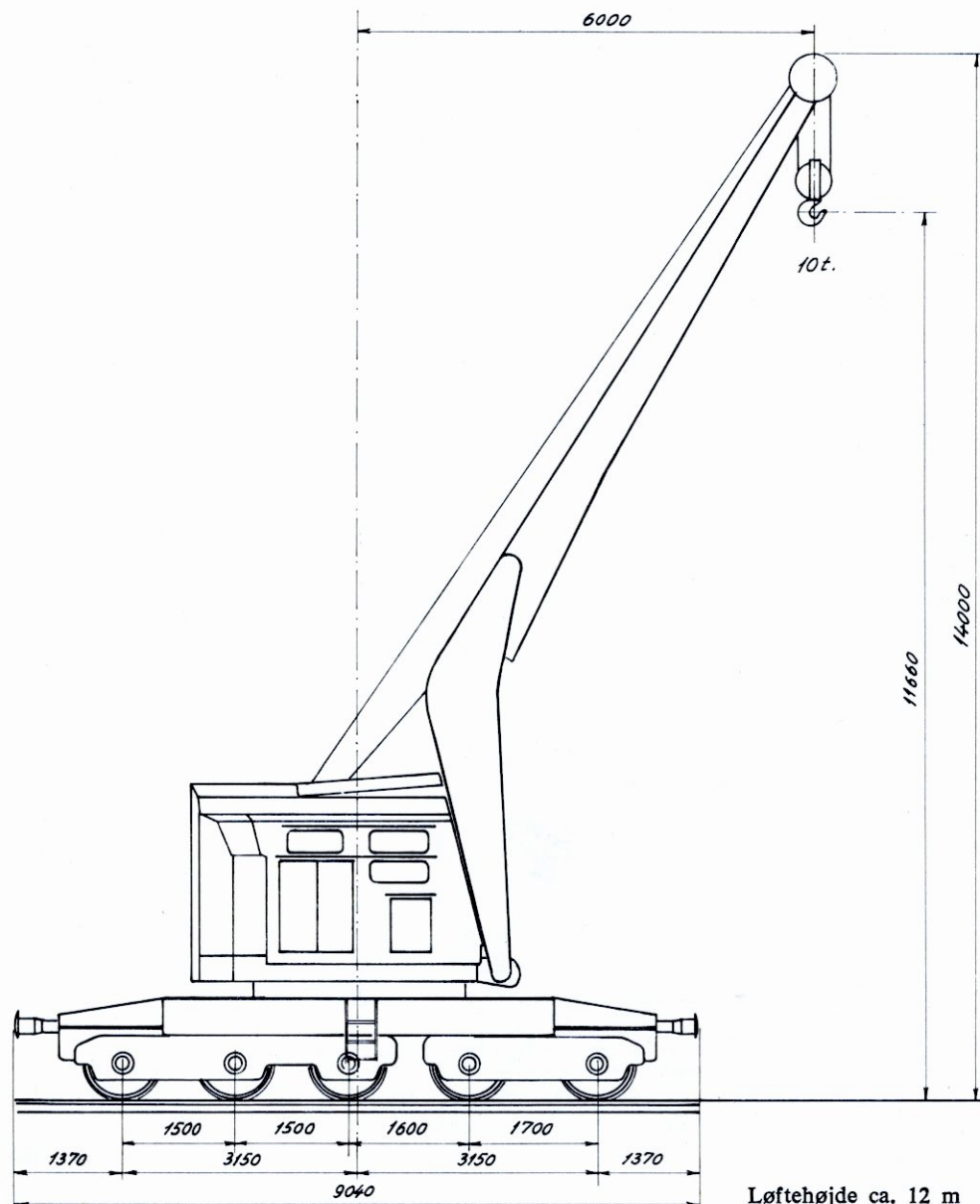

Løftehøjde ca. 12 m  
 Bæreevne maks. 15 t  
 ved 6 m udliggerradius  
 Tjenestefærdig vægt  
 85000 kg  
 Rangerskruebremse  
 Trykluftbremse  
 Befordringshastighed i tog  
 80 km/t  
 Mindste kurveradius 80 m

1963/66 Krupp-Ardelt

### 3 Skinneudlægningskraner nr. 151-153

Værkstedsområde Kh: 151

« Ar: 152-153

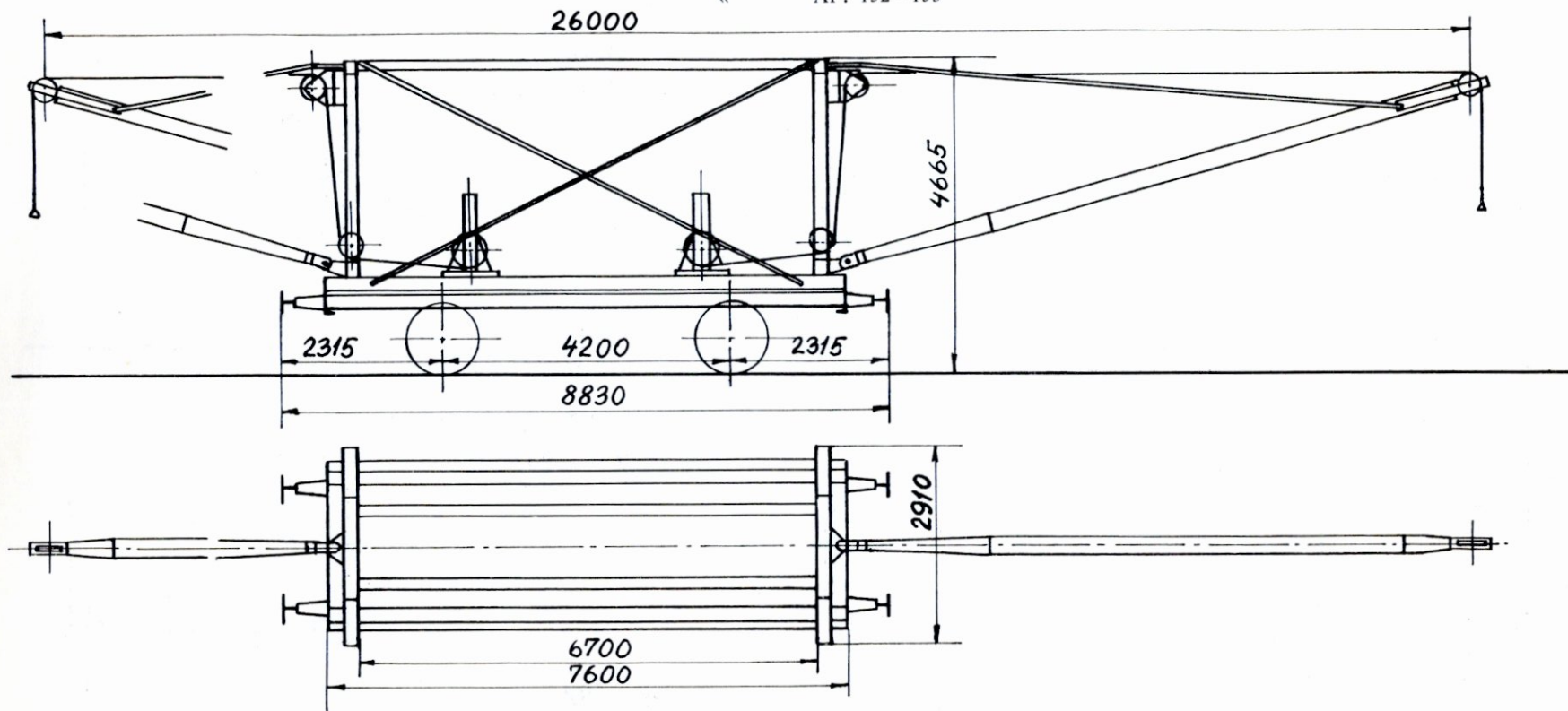

101-I

Skinneudlægningskraner

151. 1886 Scandia  
 152, 153. 1883 Breslau  
 152. Ombygget 1933 København  
 151, 153. « 1934 «

Bæreevne for hver kran 1000 kg.  
 Tjenstf. vægt 15400 «  
 Nr. 152 Trykluftledning

## 1 Skinneudlægningskran nr. 154

Værkstedssområde: Kh

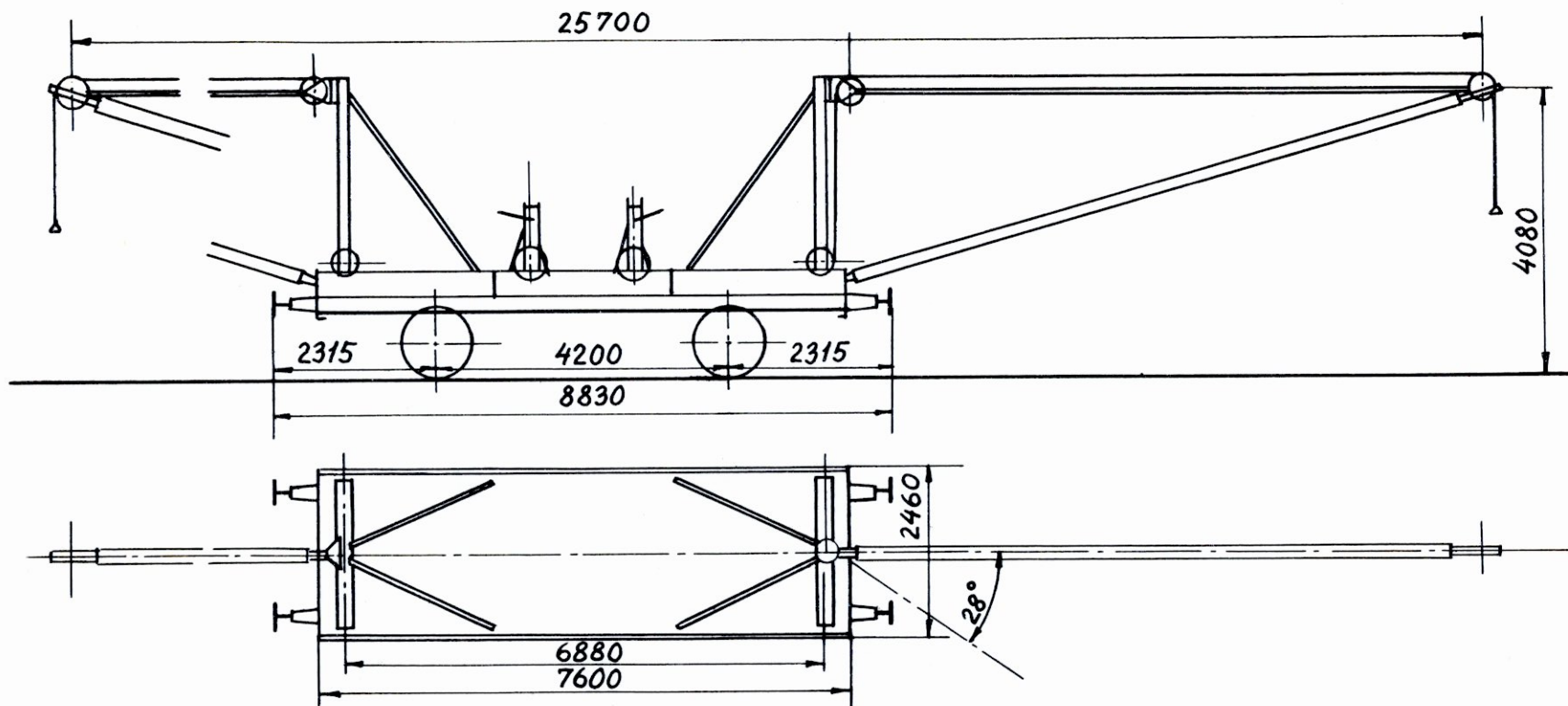

1924 Scandia  
Ombygget 1933 København

Bæreevne for hver kran 1000 kg  
Tjenstf. vægt 17150 «

### 3 Skinneudlægningskraner nr. 151-153

Værkstedssområde: Ar

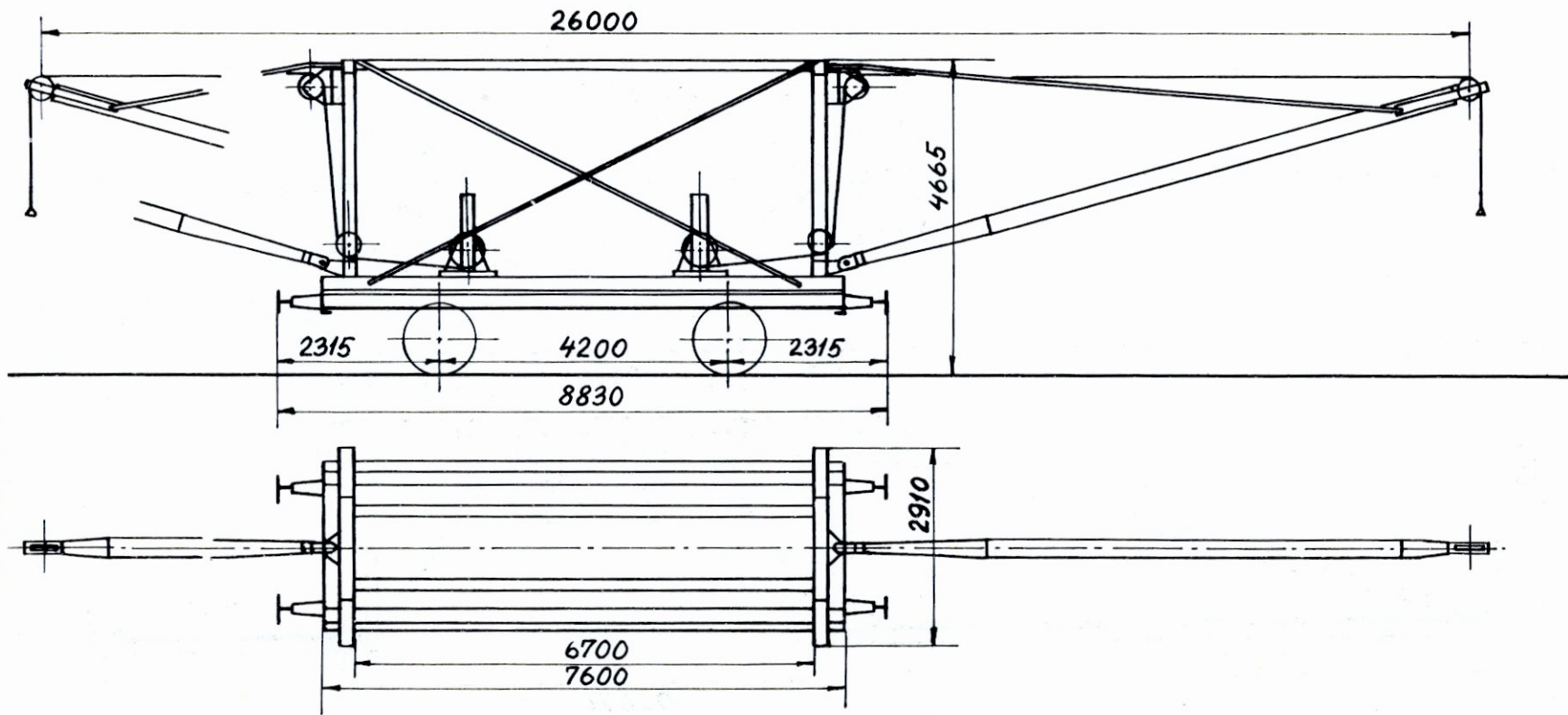

151. 1886 Scandia

152, 153. 1883 Breslau

152. Ombygget 1933 København

151, 153. Ombygget 1934 København

Hører til svejseanstalten i Fredericia,  
og må ikke anvendes på strækninger.  
Der hører ingen løbevogne til kranerne.

Bæreevne for hver kran 1000 kg.  
Tjenstf. vægt 15400 kg.  
Nr. 152 Tryklufsledning

# 1 Skinneudlægningskran nr. 154

Værkstedsområde: Ar

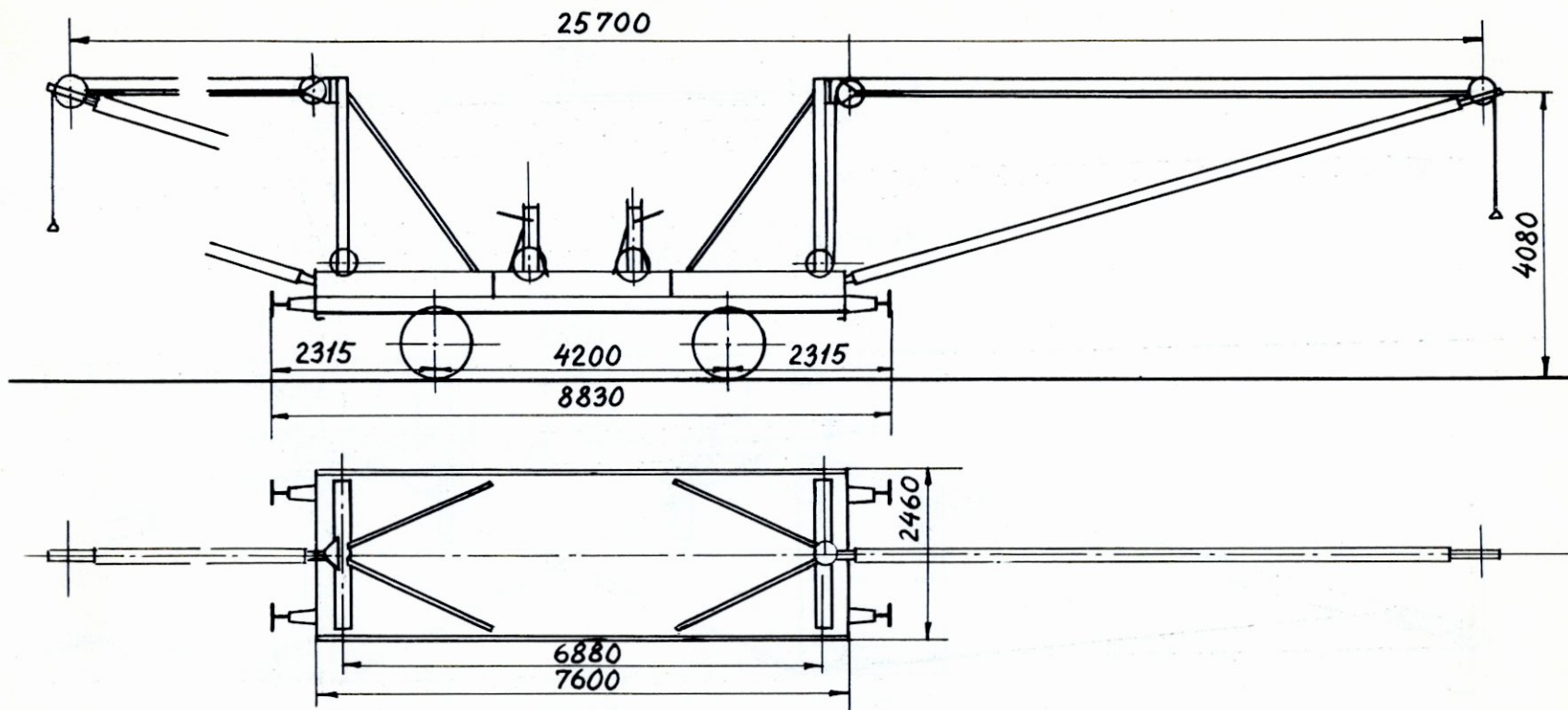

1924 Scandia  
Ombygget 1933 København

Hører til svejseanstalten i Fredericia,  
og må ikke anvendes på strækninger.  
Der hører ingen løbevogne til kranerne.

Bæreevne for hver kran 1000 kg.  
Tjenstf. vægt 17150 kg.

## I Specialvogn nr. 423

Værkstedsområde: Kh

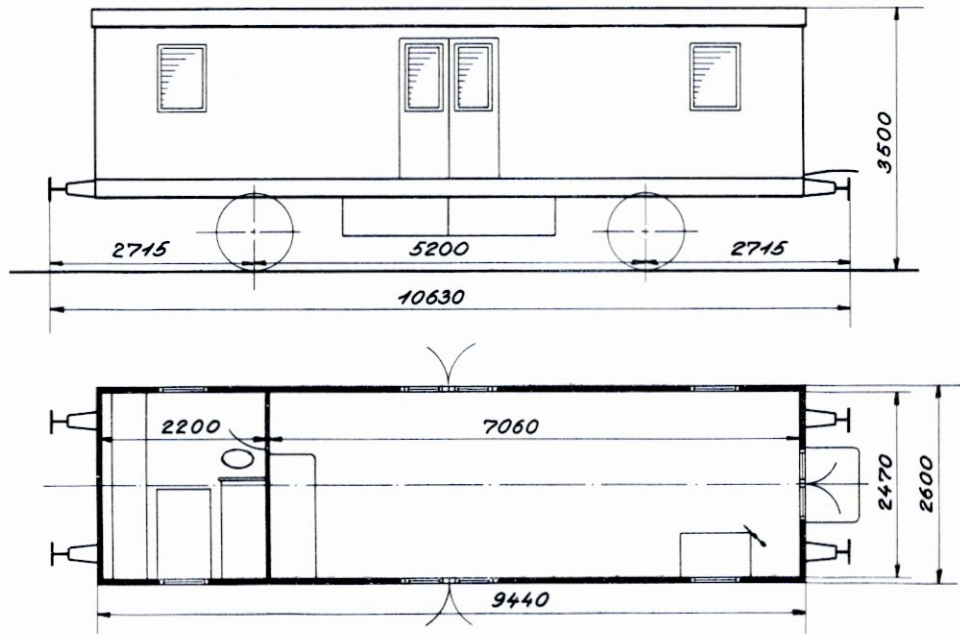

1911 Scandia  
ombygget 1956 København

Hjemsted: Københavns Godsbanegård  
Til brug som værkstedsvogn  
for kørekran nr. 143

Vognavægt 15 t  
Trykluftbremse  
Skruerbremse  
Nødbremse  
Brændeovn  
Gasbelysning



## I Specialvogn nr. 424

Værkstedsområde: Ar

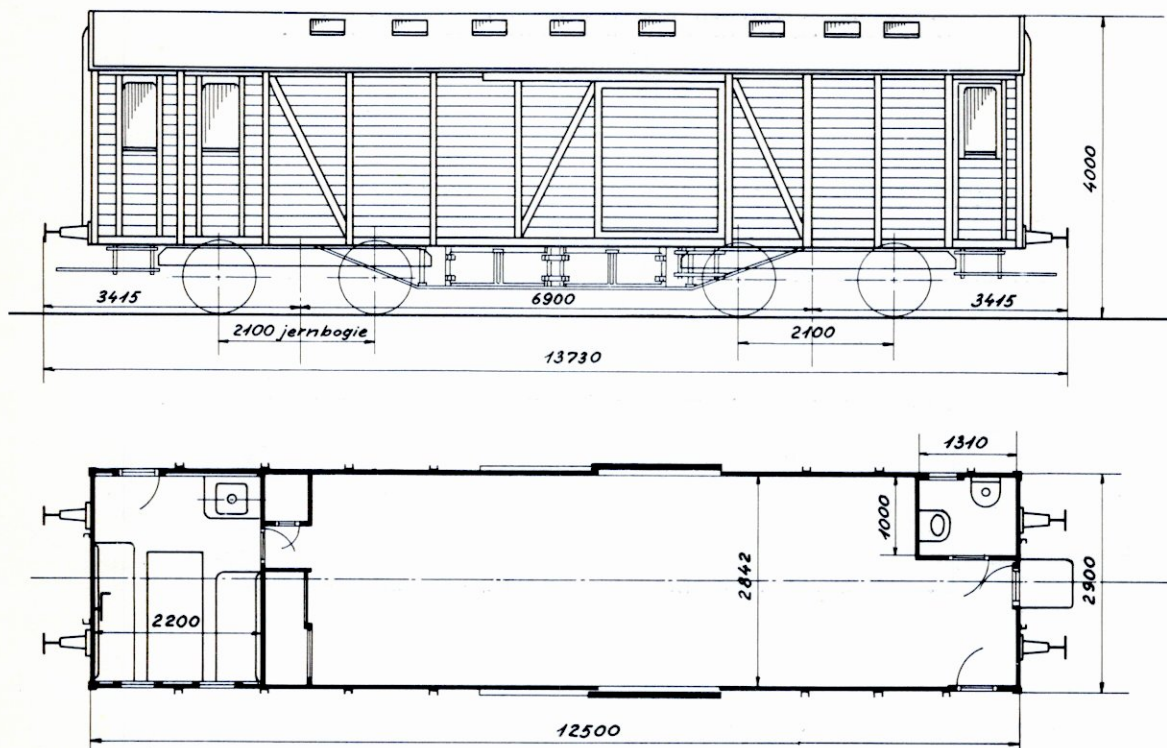

1927 Scandia  
Ombygget 1951 Århus

Hjemsted: Århus  
Petroleumslamper  
Højtryksvarmeapparater  
Kakkelovn  
Gasbelysning  
Til brug som værkstedsvogn  
for kørekran nr. 144

Tjenstf. vægt 32800 kg  
Nødbremseindretning  
Skruebremse

### 3 Olievogne nr. 1, 2, 3

Værkstedsområde } Ar nr. 1  
 } Kh nr. 2

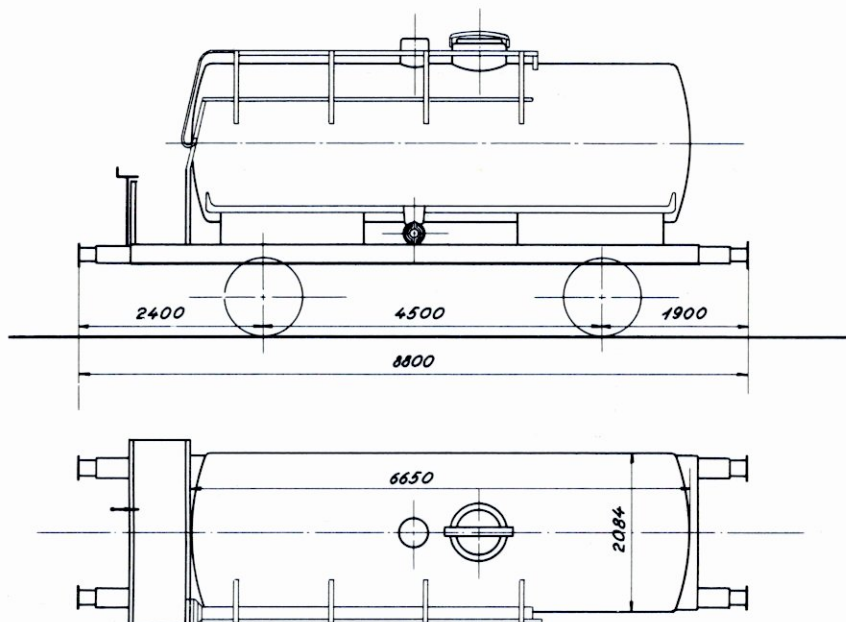

1942 Scandia

Nr. 1. Hjemsted: Århus Mdt.  
 Nr. 2 og 3. Hjemsted: Helgoland Mdt.  
 Vognene er påmalet:  
 »Må kun benyttes til transport af  
 solarolie til brug for motordriften«

Tara ca. 11800 kg  
 Rumindh.: 22,0 m<sup>3</sup>  
 Last 18000 kg  
 Nr. 1, 2. Trykluftbremse  
 Nr. 3. Trykluftledning  
 Rangerskruebremse

## 2 Specialvogn nr. 431

Værkstedsområde: Ar

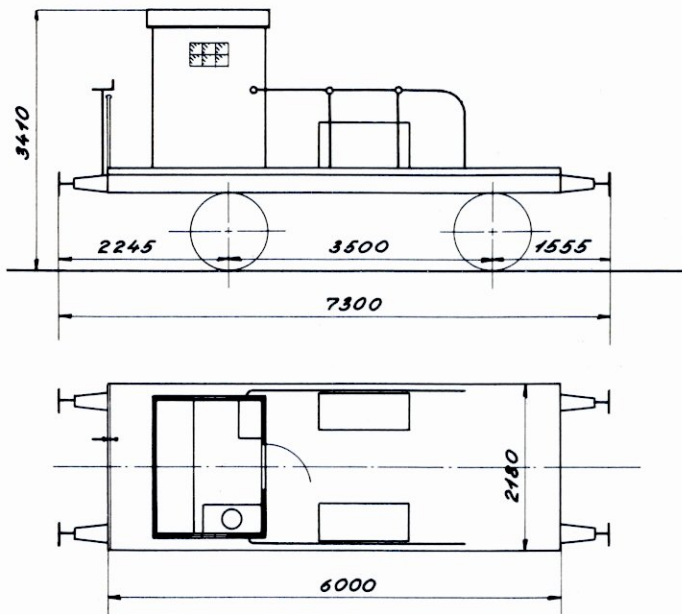

1919 Harkort-Duisborg  
ombygget 1954 Århus

Hjemsted: Centralværkstedet, Århus  
Til brug som løbevogn  
for kørekraner

Tara ca. 7000 kg  
Trykluftledning  
Rangerskruebremse  
Brændeovn

## 1 Specialvogn nr. 432

Værkstedsområde: Kh

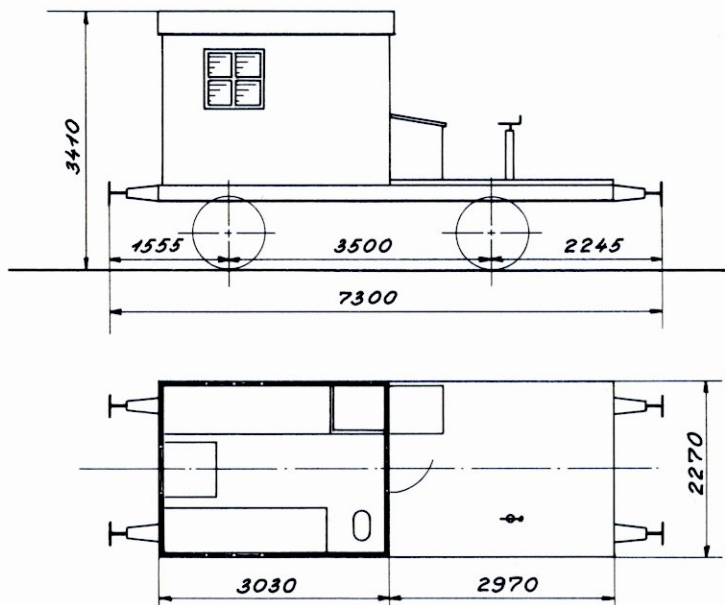

1919 Harkort-Duisborg  
ombygget 1954 København

Hjemsted:  
Centralværkstedet, København  
Maks.hast 60 km/t  
Til brug som løbevogn  
for kørekraner

Tara ca. 7600 kg  
Trykluftledning  
Rangerskruebremse

## 2 Specialvogn nr. 425-426

425 Hjemsted: Kh

426 Hjemsted: Fa

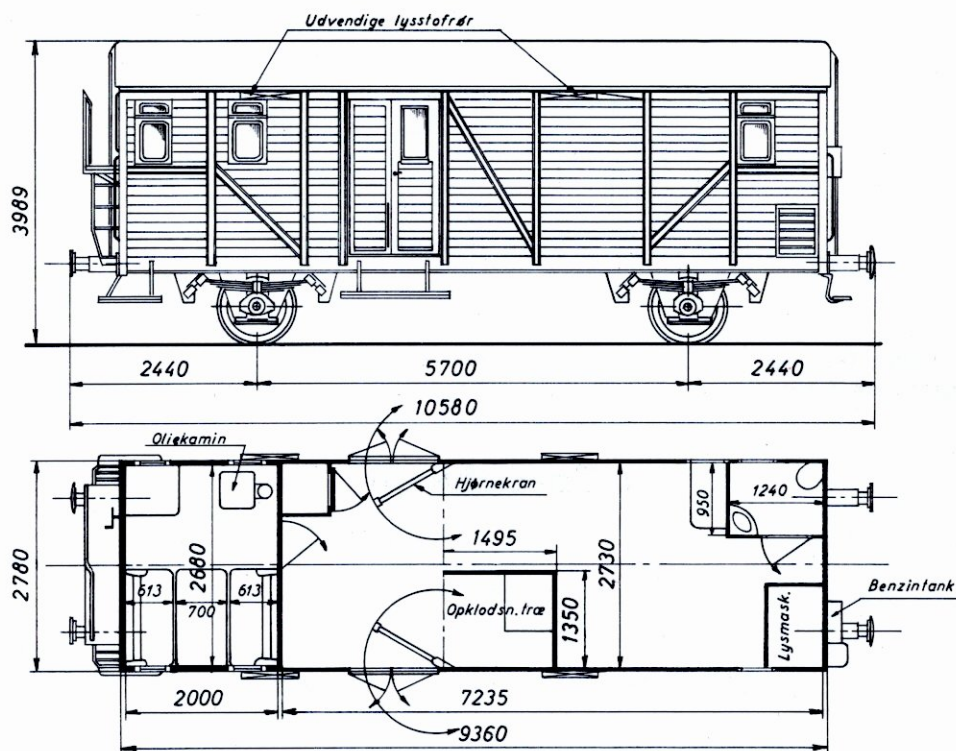

1958 Scandia  
Omb. 1967 København

Benzindrevet lysmaskine  
Olieovn  
Dampvarmeledning  
425 til brug som værkstedsvogn  
For kørekran nr. 145  
426 til brug som værkstedsvogn  
for kørekran nr. 146

Tjenstfærdig vægt 20 t  
Trykluftbremse  
Nødbremse  
Rangerskruebremse

# I Specialvogn nr. 431

Værkstedsområde: Ar

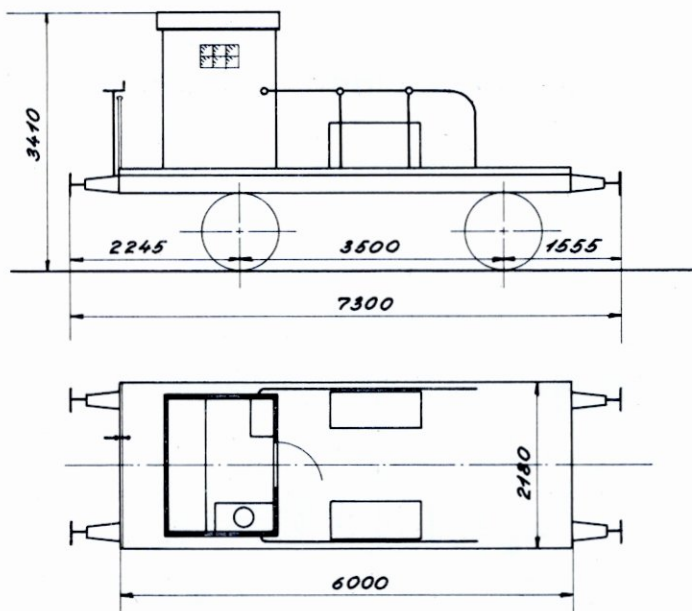

1919 Harkort-Duisborg  
ombygget 1954 Århus

Hjemsted: Centralværkstedet, Århus  
Til brug som løbevogn  
for kørekraner

Tara ca. 7000 kg  
Trykluftledning  
Rangerskruebremse  
Brændeovn

# 1 Specialvogn nr. 432

Værkstedsområde: Kh

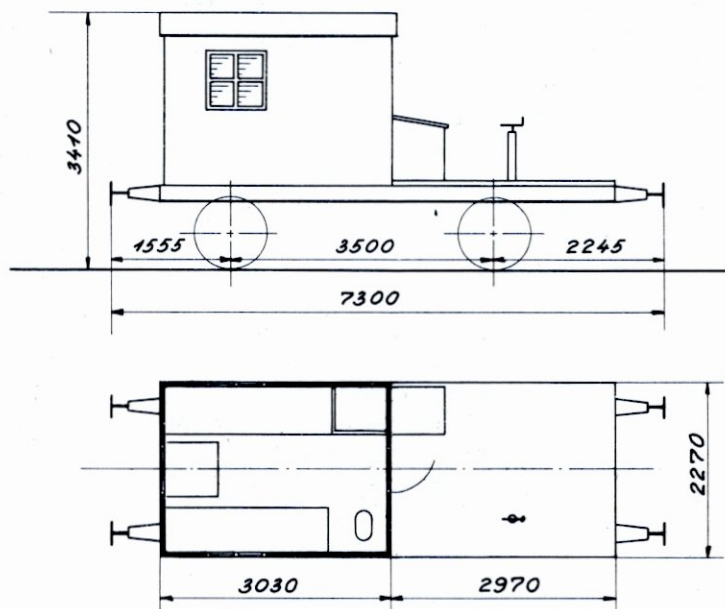

1919 Harkort-Duisborg  
ombygget 1954 København

Hjemsted:  
Centralværkstedet, København  
Maks.hast 60 km/t  
Til brug som løbevogn  
for kørekraner

Tara ca. 7600 kg  
Trykluftledning  
Rangerskruebremse

## I Specialvogn nr. 433

Værkstedso mråde: Kh

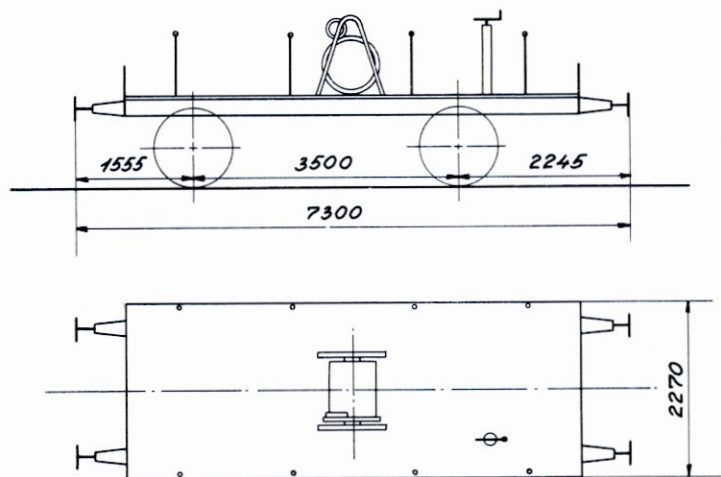

1919 Harkort-Duisborg  
ombygget 1954 København

Hjemsted:  
Centralværkstedet, København  
Maks.hast. 60 km/t  
Til brug som løbevogn  
for kørekraner

Tara ca. 7400 kg  
Trykluftledning  
Rangerskruebremse

## I Specialvogn nr. 434

Værkstedso mråde: Ar

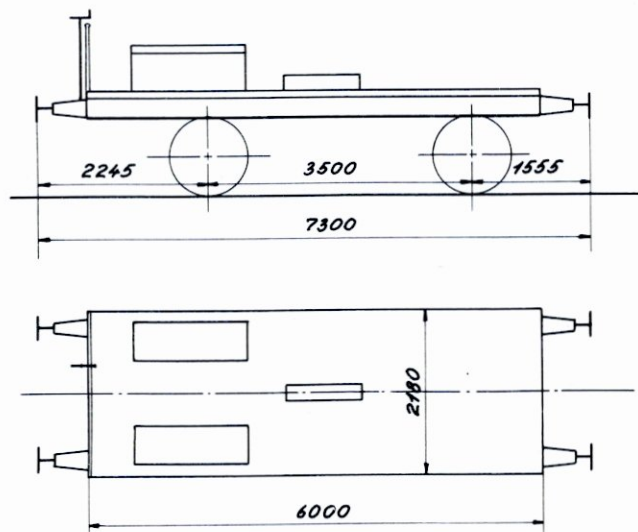

1919 Harkort-Duisborg  
ombygget 1954 Århus

Hjemsted: Centralværkstedet Århus  
Til brug som løbevogn  
for kørekraner

Tara ca. 6500 kg  
Trykluftledning  
Rangerskruebremse

## I Specialvogn nr. 435

Værkstedsovmråde: Kh

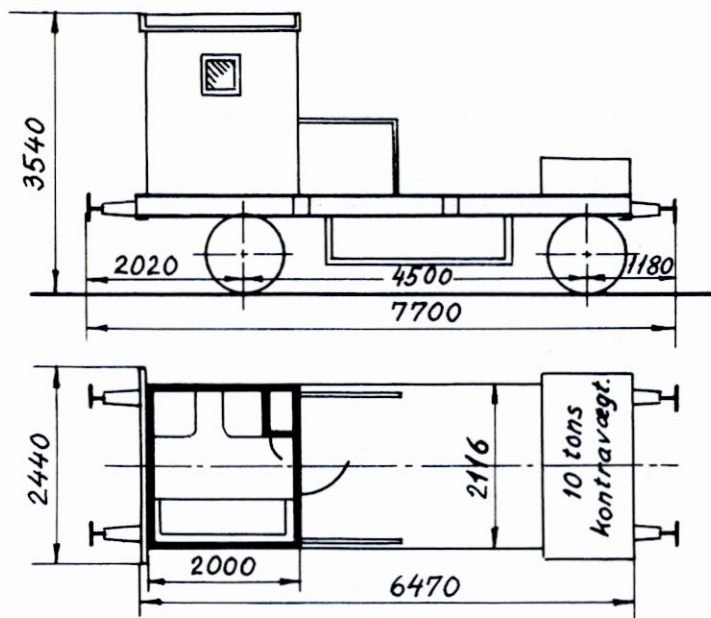

1934 København

Hjemsted:  
 »Københavns Godsbanegård«  
 Til brug som løbevogn  
 for kørekraner

Tjenstf. vægt ca. 18200 kg  
 Håndbremse

## I Specialvogn nr. 436

Værkstedsovmråde: Kh

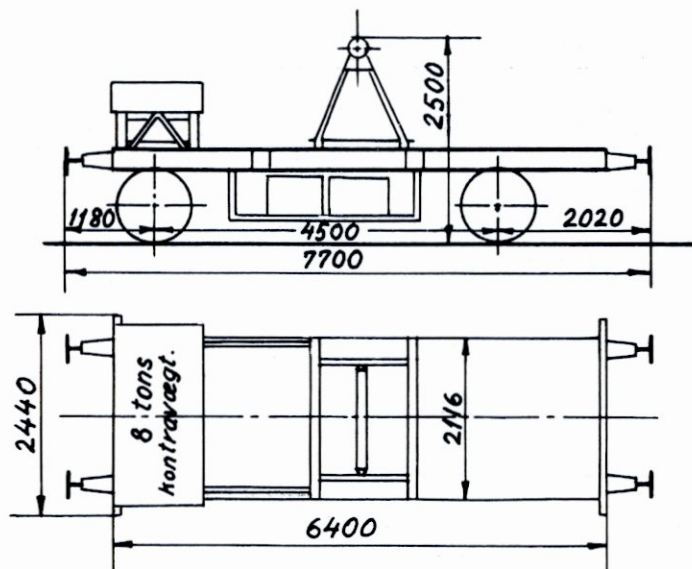

1934 København

Hjemsted:  
 »Københavns Godsbanegård«  
 Til brug som løbevogn  
 for kørekraner

Tjenstf. vægt  
 med kranens udligger ca. 18200 kg  
 Håndbremse

# I Specialvogn 445

Værkstedsområde: Kh.

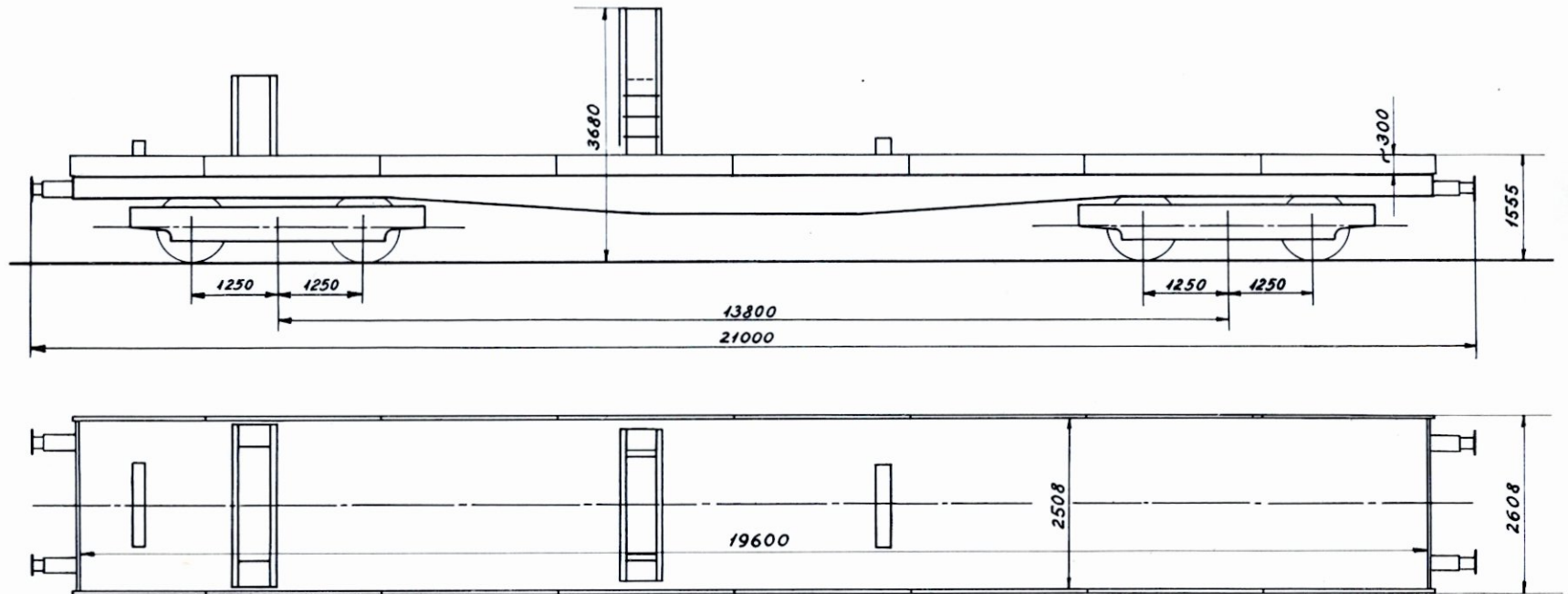

108a-1

1929 Odense  
ombygget 1958, København

Til brug som løbevogn for  
skinneudlægningskran nr. 155

Tara ca. 25 500 kg  
Last 9000 kg  
Trykluftbremse

Løbevogn



1900

Handwritten text, mostly illegible due to fading and bleed-through.

THE UNIVERSITY OF CHICAGO



## 2 Specialvogne 438-439

438 Hjemsted Fa

439 Hjemsted Kh

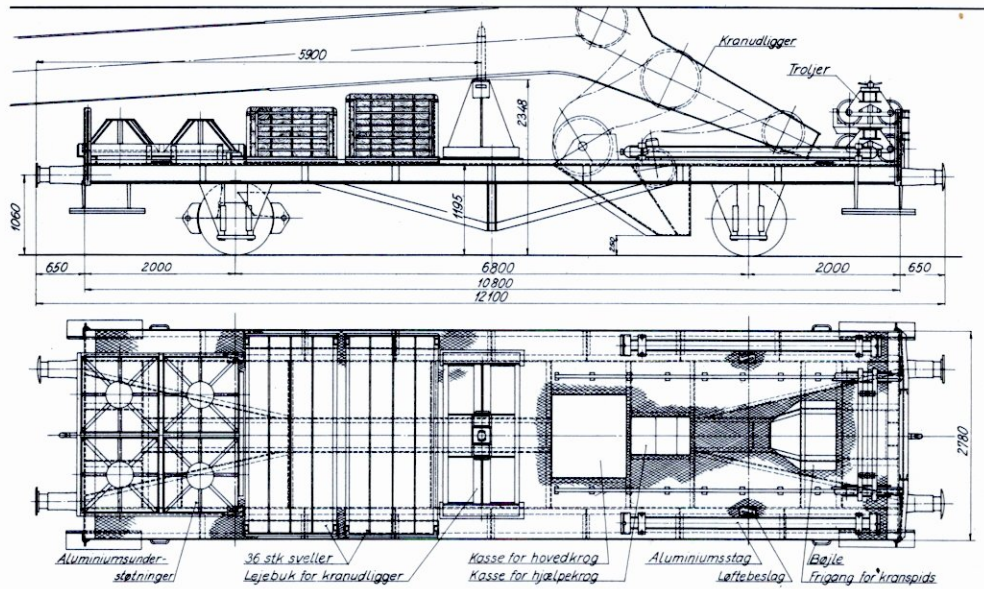

1947 Scandia  
Omb. 1967 Århus

Til brug som løbevogne for  
kørekran 145-146

Tara ca. 10200 kg  
Last 17500 kg  
Trykluftbremse  
Håndbremse

# I Specialvogn 445

Hjemsted: Kh

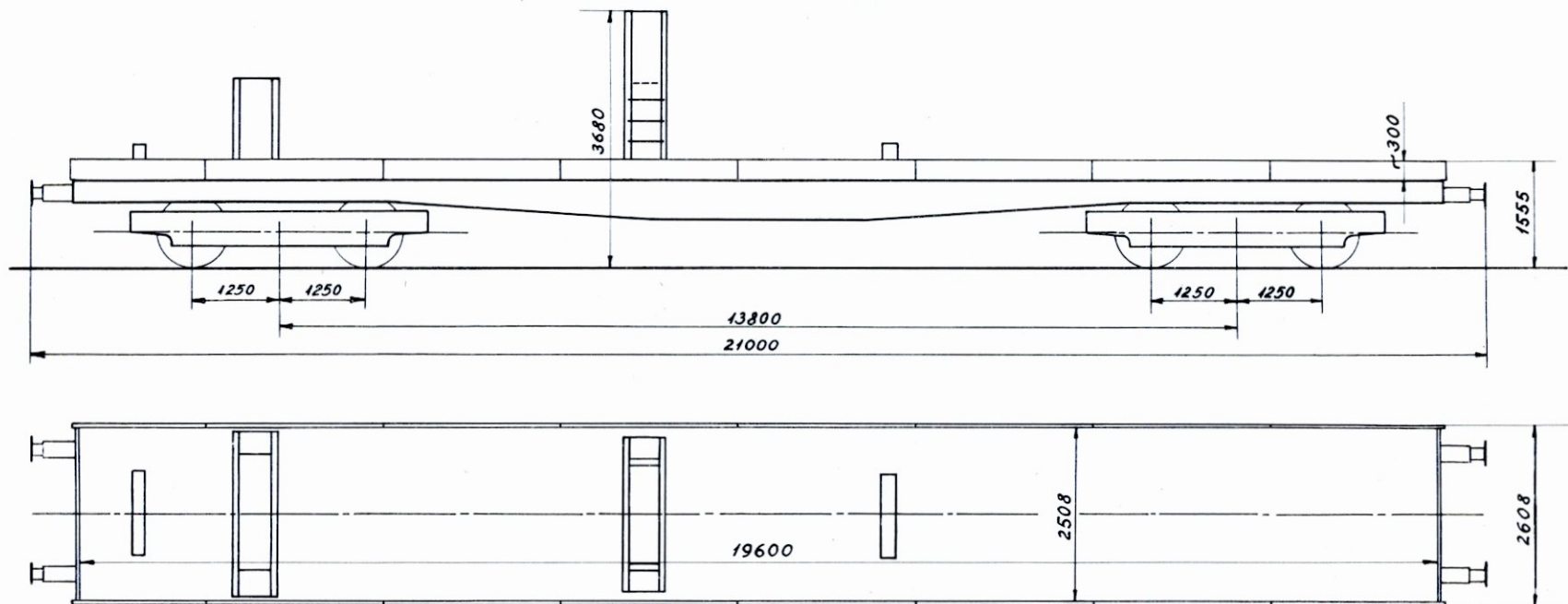

1929 Odense  
ombygget 1958, København

Til brug som løbevogn for  
skinneudlægningskran nr. 155

Tara ca. 25500 kg  
Last 9000 kg  
Trykluftbremse

# 1 Specialvogn 446

Hjemsted: Ar

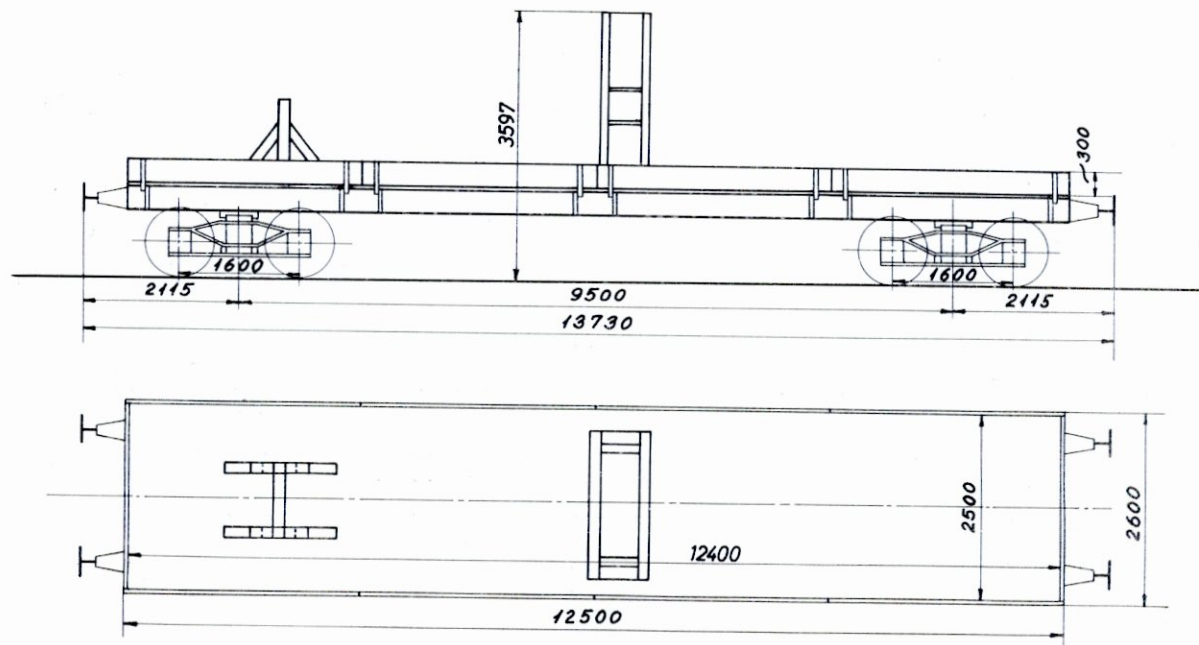

1886 Scandia  
Omb. 1963 Århus

Til brug som løbevogn for  
skinneudlægningskran nr. 156

Tara ca. 16700 kg.  
Håndbremse  
Trykluftledning

108c-1

Løbevogn

# 1 Specialvogn 447

Hjemsted: Kh

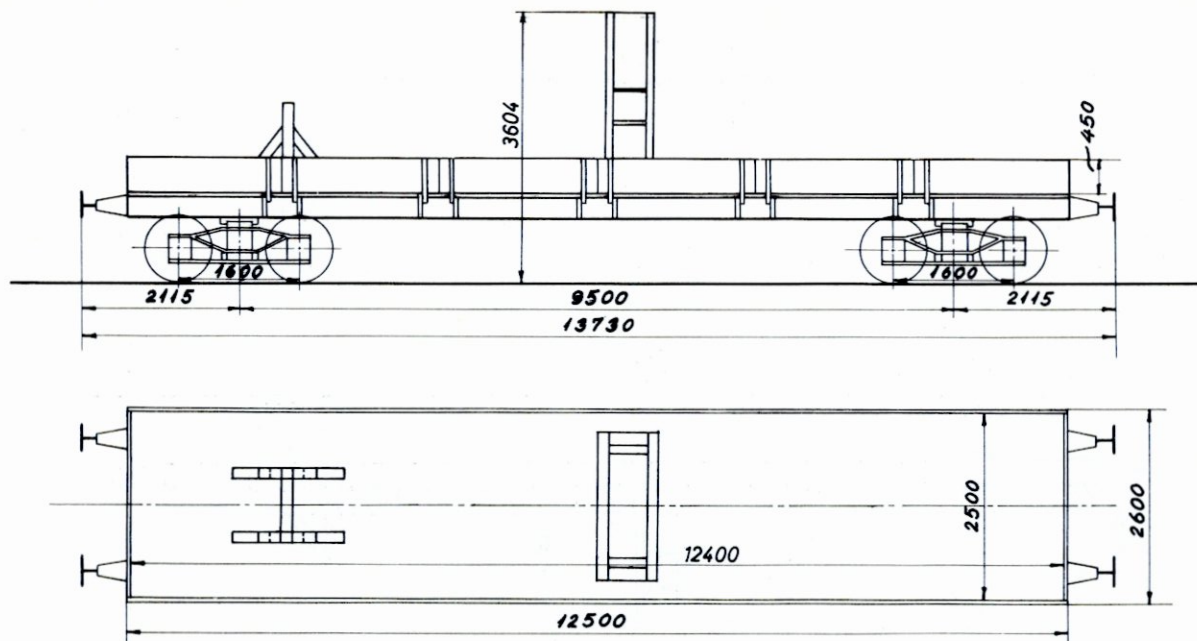

1922 Scandia  
Omb. 1966 Århus

Til brug som løbevogn for  
skinneudlægningskran nr. 157

Tara ca. 16700 kg.  
Håndbremse  
Trykluftledning

## 1 Specialvogn nr. 437

Værkstedssområde: Ar

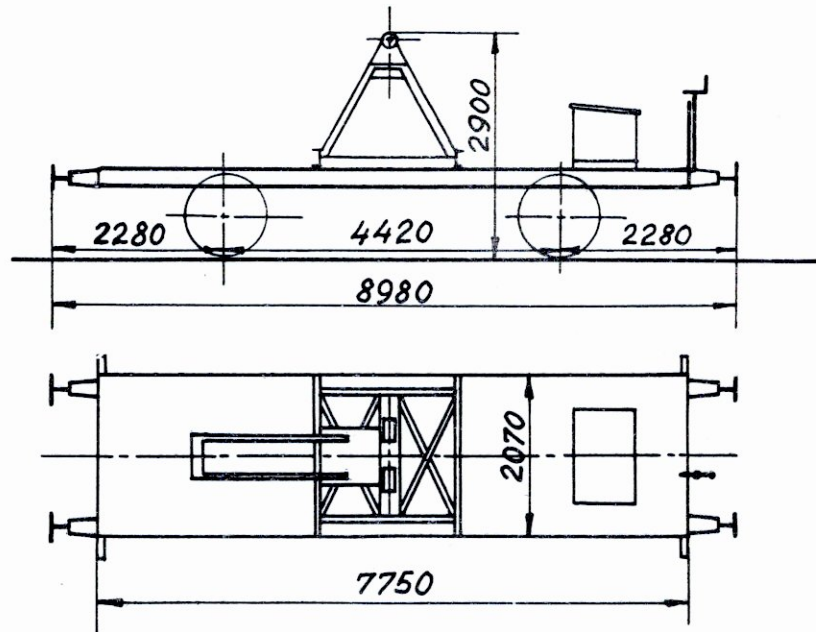

1937 København

Hjemsted: «Århus H»  
 Til brug som løbevogn  
 for kørekraner

Tjenstf. vægt med kranens  
 udligger ca. 12500 kg  
 Trykluftbremse (G-P)  
 Rangerskruebremse  
 Varmeledning

## I Specialvogn nr. 631

Værkstedsområde: Kh

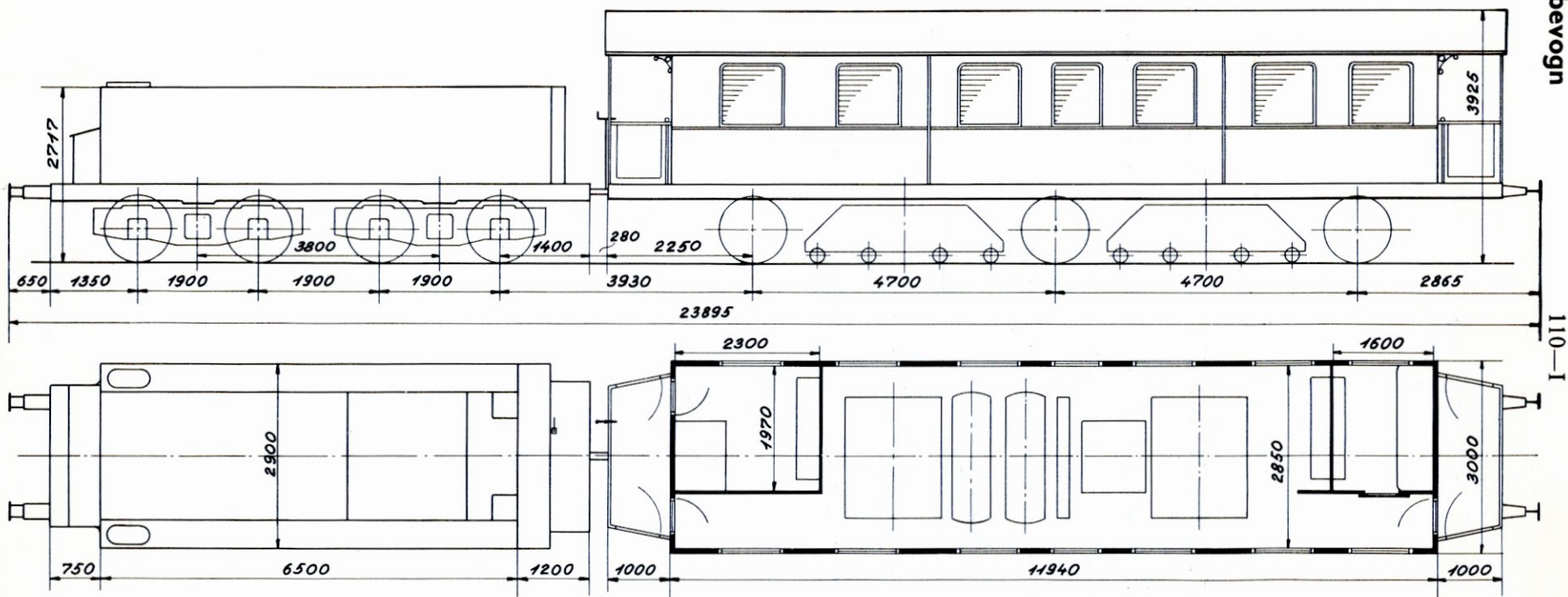

1921 Scandia  
Ombygget 1956 København

Slibevogn tara 28800 kg  
Vandvogn « 23100 »

## 2 Specialvogne nr. 651, 652

Værkstedsområde: Kh

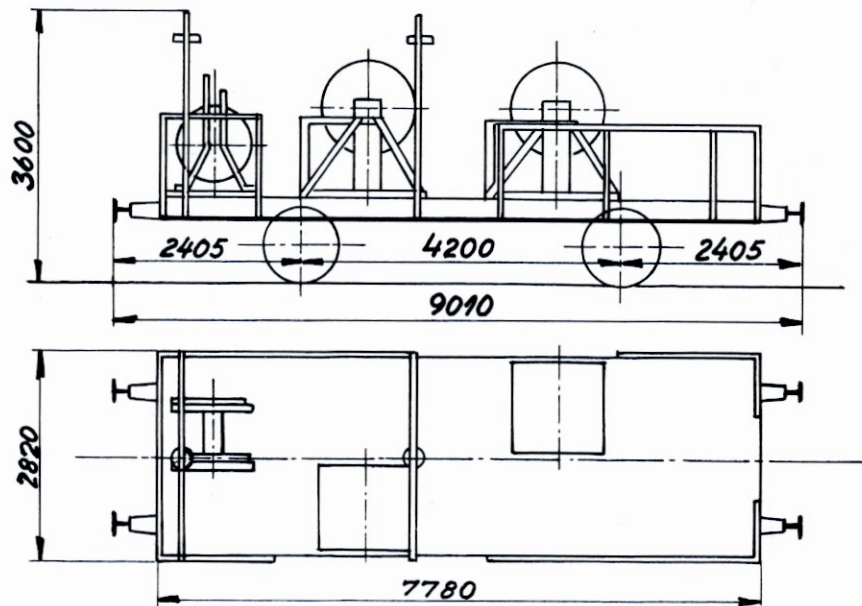

1901 Scandia  
Ombygget 1944 København

Til brug for  
Køreledningstilsynet

Last 6000 kg  
Bundfl. 21,0 m<sup>2</sup>  
Tara ca. 7200 kg  
Trykluftledning  
Nødbremsetræk



# 1 Specialvogn nr. 731

Værkstedssområde: Kh

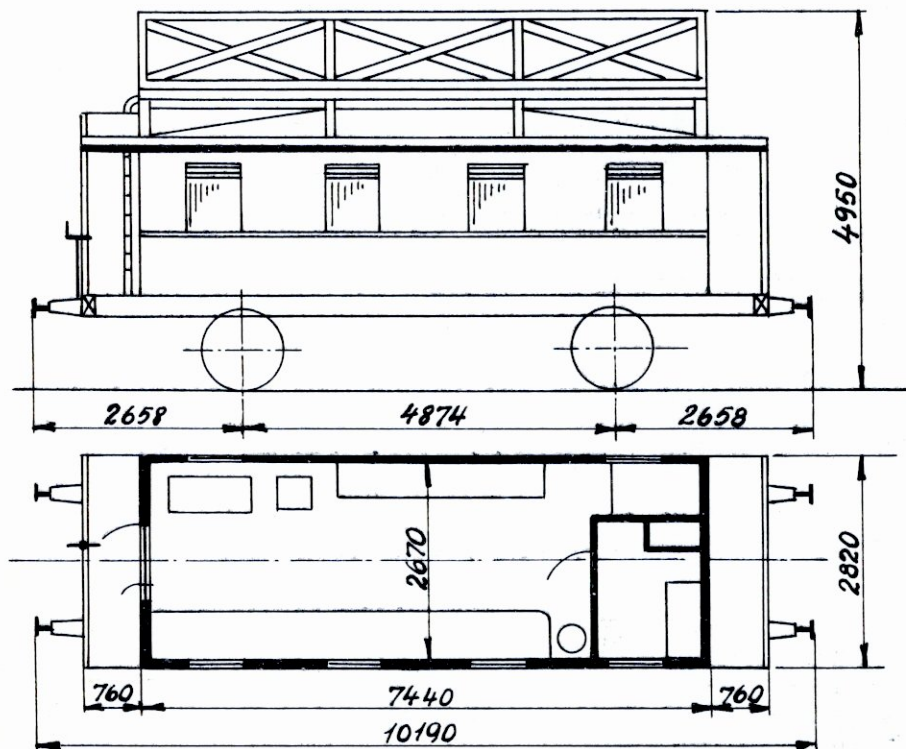

1880 Scandia  
Ombygget 1931 København

Til brug for  
køreledningstilsynet

Tara ca. 14000 kg  
Rangerskruebremse  
Trykluftledning

## 2 Specialvogne nr. 732, 733

Værkstedsovråde: Kh

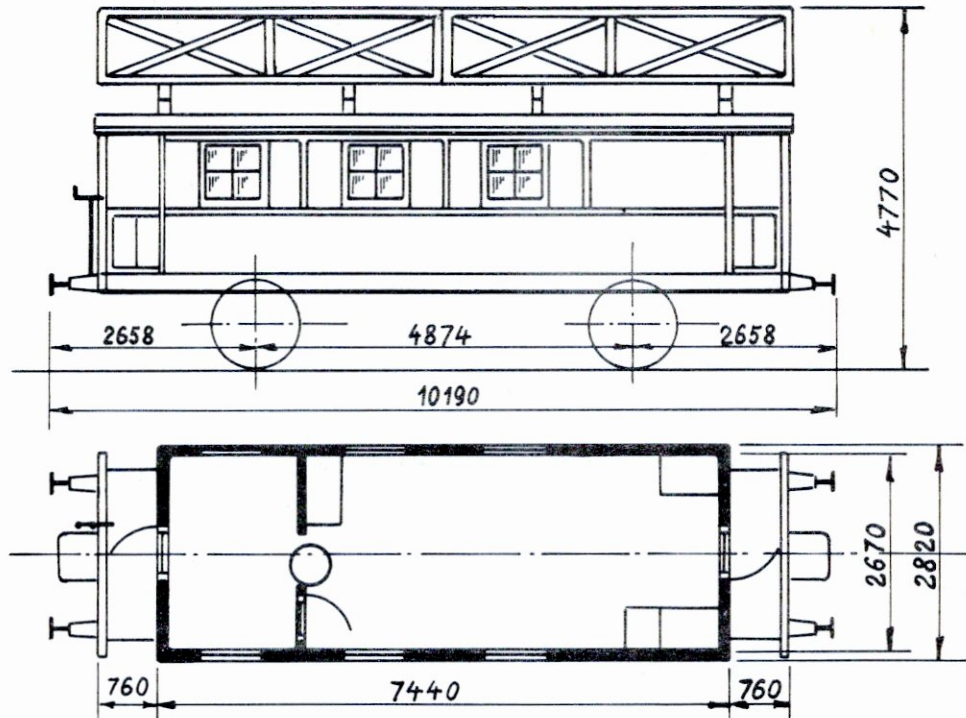

732. 1897 Strømmen  
 733. 1898 «  
 Ombygget 1937 København

Til brug for  
 køreledningstilsynet

Tara ca. 10800 kg  
 Rangerskruebremse

**1 Specialvogn nr. 734**

Værkstedsområde: Kh

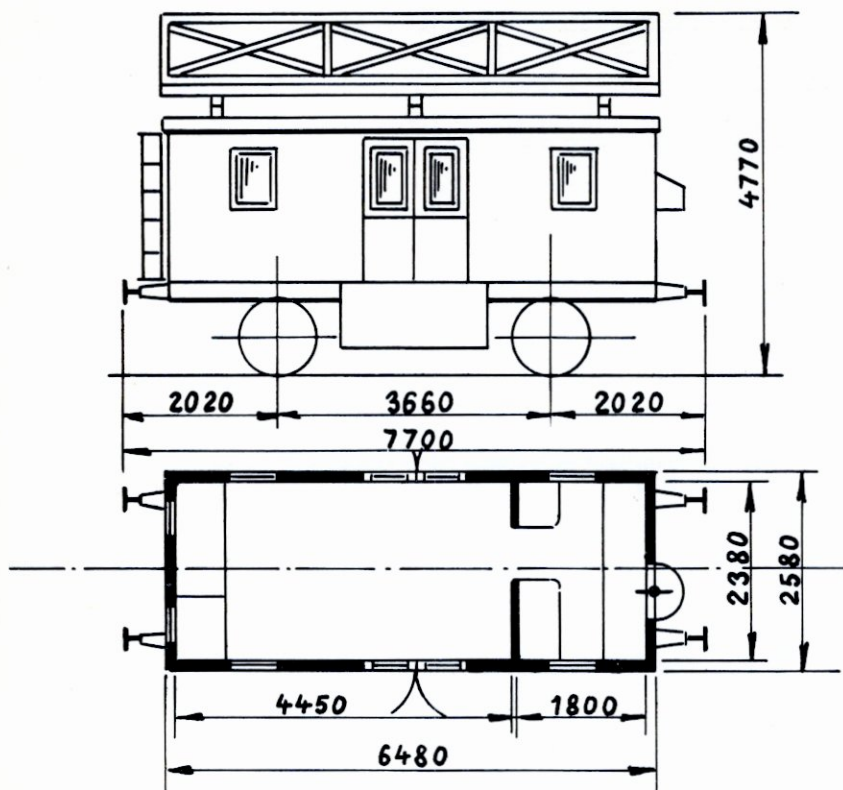

1879 Breslau  
Ombygget 1942 København

Til brug for  
køreledningstilsynet

Tara ca. 8800 kg  
Skrubremse

# 1 Specialvogn nr. 735

Værkstedsområde: Kh

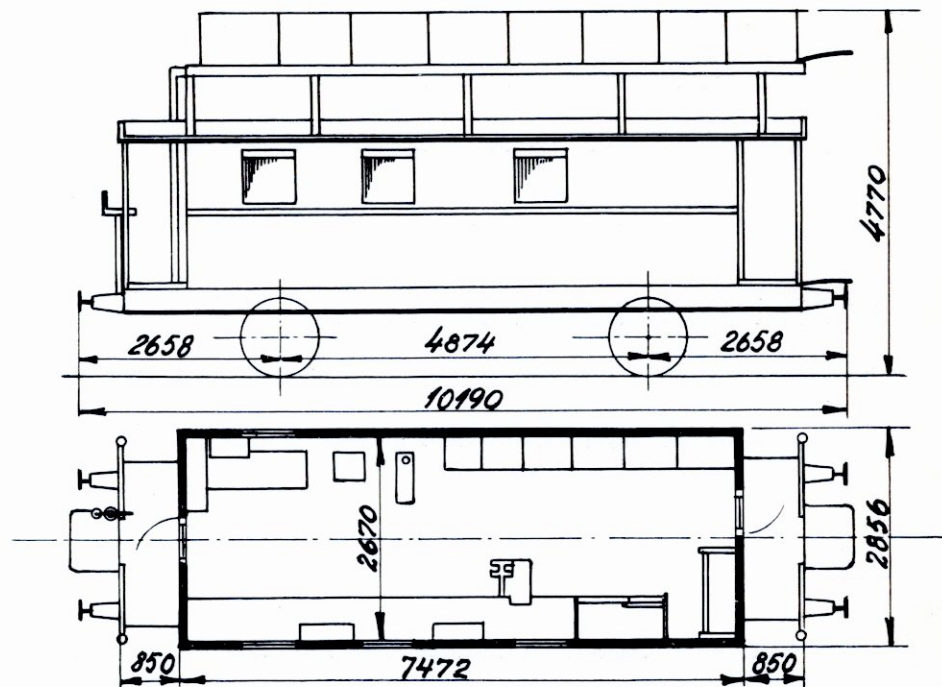

1893 Scandia  
Ombygget 1945 København

Til brug for  
køreledningstilsynet

Tara ca. 11100 kg  
Trykluftbremse (P)  
Nødbremsetræk  
Rangerskruebremse

## 1 Specialvogn nr. 736

Værkstedsområde: Kh

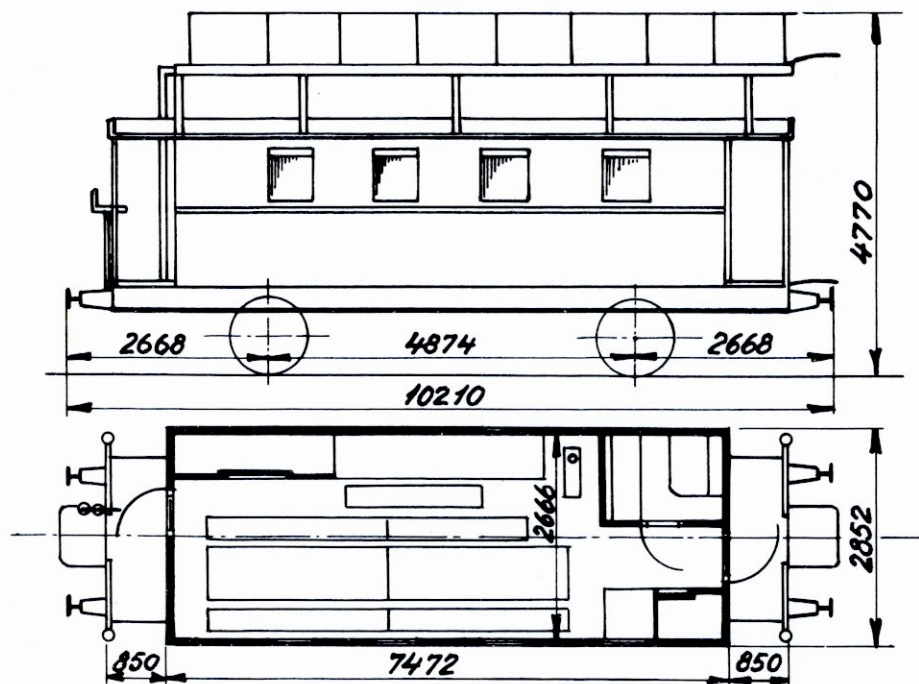

1896 Strømmen  
Ombygget 1945 København

Til brug for  
køreledningstilsynet

Tara ca. 10400 kg  
Trykluftbremse (P)  
Nødbremsetræk  
Rangerskruebremse

**1 Specialvogn nr. 751**

Værkstedsområde: Kh

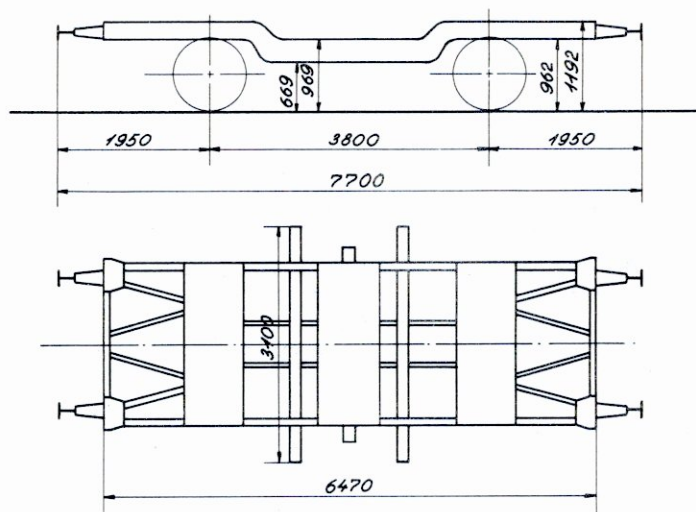

1910 Scandia  
Ombygget 1953 København

Kun til transport af transformatorer  
Hjemsted: Enghave omformerstation

Maks. hast.: { læsset 20 km/t  
tom 60 «

Last 20000 kg  
Tara ca. 6500 kg

**1 Specialvogn nr. 756**

Værkstedsområde: Kh

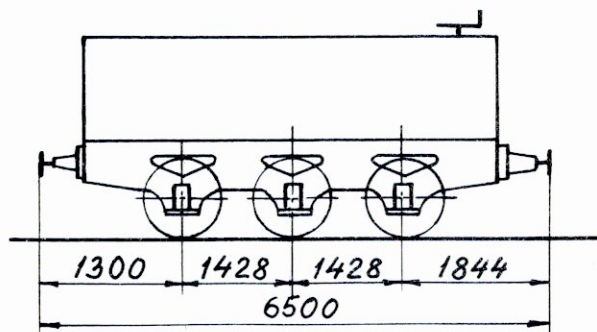

1870 Esslingen  
Ombygget 1920 København

Hjemsted: Enghave omformerstation  
Kun til brug for maskintjenesten  
og centralværkstedet til transport  
af transformatorolie

Last 12150 kg  
Tara ca. 10700 kg  
Rangerskruebremse

**2 Specialvogne nr. 761, 762**

Værkstedsområde: Kh

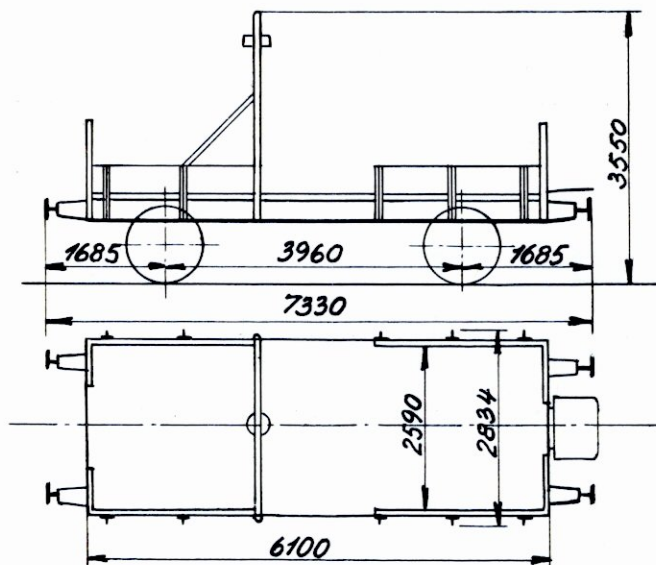

1864 Lauenstein  
Ombygget 1944 København

Til brug for  
køreledningstilsynet

Last 10000 kg  
Bundfl. 15,6 m<sup>2</sup>  
Tara ca. 5600 kg  
Trykluftledning  
Nødbremsetræk

Benævnelse	Nr.	Special- vogn nr.	Bygge- år	Fabrikations- sted	Ombygget		Længde o. puff. mm	Aksel- afstand mm	Vogn- vægt t	Bremse	Lys Varme	Hjem- sted	Vk omr.
					Vk	år							
Betonsprøjtevogn .....	1	161	1905	Scandia	Kh	1948	9800	5000	14	TL RS	0	Kh	Kh
Brovogn .....	1	165	1876	Breslau	Kh	1951	7700	3660				Gb	Kh 1)
» .....	2	166	«	»	»	»	»	»				»	» 1)
Brovægtsprøvevogn .....	1	171	1883	Borsig	Ng	1937	5800	3000	8	TL RS		Ng	Ng
» .....	2	172	1884	Hartmann	»	1933	»	»	20	» »		»	»
» .....	3	173	1882	Borsig	»	1937	»	»	28	» »		»	»
» .....	4	174	1884	Hartmann	»	1933	»	»	10	»		»	»
» .....	5	175	»	Borsig	»	»	»	»	18	»		»	»
» .....	6	176	1901	Breda	»	1937	»	»	28	»		»	»
» .....	8	178	1863	Esslingen	»		6526	2×1428	20	TL »		»	»

1) Må ikke befordres i tog.



Benævnelse	Nr.	Special- vogn nr.	Bygge- år	Fabrikations- sted	Ombygget		Længde o. puff. mm	Aksel- afstand mm	Vogn- vægt t	Bremse	Lys Varme	Hjem- sted	Vk omr.
					Vk	år							
Brændevogn .....	1	181	1920	Hark. Duisb.			6610	3500		H		Kh	Kh
» .....	2	182	»	»			»	»		»		»	»
» .....	3	183	»	»			»	»		»		»	»
» .....	4	184	»	»			»	»		»		»	»
» .....	5	185	»	»			»	»		»		»	»
» .....	6	186	»	»			»	»		»		»	»
» .....	7	187	»	»			»	»		»		»	»
» .....	8	188	»	»			»	»		»		»	»
» .....	9	189	»	»			»	»		»		»	»
» .....	10	190	»	»			»	»		»		»	»
» .....	11	191	»	»			»	»		»		»	»
» .....	12	192	»	»			»	»		»		»	»
» .....	13	193	»	»			»	»		»		»	»
» .....	14	194	»	»			»	»		»		»	»
» .....	15	195	»	»			»	»		»		»	»
» .....	16	196	»	»			»	»		»		»	»

Bygningsvogn	3	253	1875	Wagenbau	Ng	1929	7700	3660		TL	H		Oj	Ar
»	4	254	1896	Strømmen	Ar	1939	10190	4874		»	RS		Rd	»
»	5	255	1883	Atlas	»	1949	7330	3960	12	»	H		Ab	»
»	7	257	»	»	»	1948	»	»	»	»	»		Rå	»
»	9	259	»	»	»	1949	»	»	»	»	»		Vj	»
»	11	261	1856	Lauenstein	»	1915	6290	3050		TL	»		Hj	»
»	12	262	1906	»	»	1955	10700	5700	12	»	»	0	Ar	»
»	13	263	1882	Breslau	»	1926	9000	4200		»	»		Rd	»
»	15	265	1897	Strømmen	»	1938	10190	4874			RS		Str	»
»	17	267	1886	Preetz	»	1949	7740	3960	12	TL	H		Bb	»
»	18	268	1898	Scandia	»	1937	9870	4700		»	S	0	Ab	»
»	19	269	1879	Zypen	»	1944	7700	3660		»	H	0	Sl	»
»	20	270	1898	Scandia	Kh	1946	9870	4700		»	»	0	Van	Kh
»	21	271	1877	»	Ar	1931	7700	3660		»	»		Sdb	Ar
»	23	273	1876	Randers	»	1932	»	»		»	S		Rq	»
»	24	274	1870	Lauenstein	Kh	1947	8840	4420		»	H	0	Hg	Kh
»	27	277	1875	Wagenbau	Ar	1933	7700	3660			S		Ng	Ng
»	28	278	»	»	»	»	»	»		TL	H		»	»
»	29	279	1877	Breslau	»	1934	»	»		»	»		Hr	Ar
»	32	282	1897	Scandia	Kh	1946	9000	4200		»	»	0	Fb	Kh
»	34	284	1893	»	Ar	1938	10190	4874		»	RS		Sj	Ar
»	35	285	1876	Randers	Kh	1940	7700	3660			S		Kj	Kh
»	36	286	1898	Scandia	»	1947	9870	4700		TL	H	0	Hi	»
»	37	287	1899	»	Ng	»	»	»		»	»		Tp	Ng
»	38	288	1917	Breslau	Ar	1953	9580	4570		»	»	0	Ar	Ar
»	39	289	1924	Scandia	Kh	1956	13070	8000		TL	RS	El-stik 0	Gb	Kh
»	40	290	1876	Wagenbau	Ar	1946	8730	4270	12	»	H		Lg	Ar

Benævnelse	Nr.	Special- vogns nr.	Bygge- år	Fabrikations- sted	Ombygget		Længde o. puff. mm	Aksel- afstand mm	Vogn- vægt t	Bremse	Lys Varme	Hjem- sted	Vk omr.
					Vk	år							
Bygningsvogn .....	41	291	1906		Kh	1954	10700	5700	12	TL H	0	Hk	Kh
» .....	42	292	1915	Sydfyn	»	1951	8630	3900	»	» »		Gb	»
» .....	43	293	1924	Scandia	Ar	1958	14400	9000	17	» RS	El-stik 0	Vg	Ar
» .....	44	294	1875	Wagenbau	»	1947	7700	3660	12	» H		Tdr	»
» .....		295	1921	Scandia	»	1958	14400	9000	15	» »	El-stik 0	Ab	»
» .....	46	296	1922	Scandia	Kh	1948	12210	6300	15	» S	0	Van	Kh
» .....	47	297	»	»	»	1949	»	»	13	» »	»	Rg	»
» .....	48	298	»	»	»	»	»	»	12	» »	»	Nf	»
» .....	49	299	1907	»	»	»	11730	»	»	» »	»	Vo	»
» .....	50	300	»	»	»	»	»	»	»	» RS	»	Sg	»
» .....	53	303			Ar	1950	9320	4420	12	» H		Od	Ng
» .....	54	304	1916	S F J	»	»	8970	»	»	» »		Aat	Ar
» .....	55	305	1884	Breslau	Ng	»	7330	3960	»	» »	0	Svg	Ng
» .....	56	306	1899	Scandia	Ar	1954	8690	3660	»	» »	»	Gi	Ar
» .....	57	307	1886	Skabo	»	1955	10600	5000	12	» »	El-stik »	Rj	»

Elektrikere, værkstedsvogn for . .	1	351	1876	Wagenbau	Kh	1946	7700	3660			H		Kh	Kh
» » » ..	4	354	1898	Görlitz	Ar	1954	9980	4700	12		»		Ar	Ar
» » » ..	5	355	1886	Skabo	»	1955	10600	5000			»	0	»	»
» » » ..	6	356	1924	Scandia	Kh	1956	13070	8000	15	TL RS	El-stik	»	Kh	Kh
» » » ..	7	357	»	»	»	»	»	»		» »	» »	»	»	»
Færgenvogn . . . . .	2	362	1919	Zwickau	Kh	1953	8800	4000			RS		Ge	Kh
» . . . . .	3	363	»	»	»	»	»	»			»		»	»
» . . . . .	4	364	»	MAN	»	»	»	»			»		»	»
» . . . . .	5	365	1920	Breslau	»	»	»	»			»		»	»
» . . . . .	6	366	»	»	»	»	»	»			»		»	»
» . . . . .	7	367	»	»	»	»	»	»			»		»	»
» . . . . .	8	368	1919	Bremen	»	»	»	»			»		»	»
» . . . . .	9	369	»	MAN	»	»	»	»			»		»	»
Kedelsmede, værkstedsvogn for . .	1	381	1864	Launstein	Kh	1952	8500	4270	12	TL H	El-stik 0		Kh	Kh

Benævnelse	Nr.	Special- vogns nr.	Bygge- år	Fabrikations- sted	Ombygget		Længde o. puff. mm	Aksel- afstand mm	Vogn- vægt t	Bremse	Lys Varme	Hjem- sted	Vk omr.
					Vk	år							
Kedelvogn . . . . .	2	382	1885	Atlas			9980	4720		S			Ar
» . . . . .	3	383	1886	Breslau			»	»		»			»
» . . . . .	8	388	1884	»			9000	4200		»			»
» . . . . .	9	389	1899	Scandia	Kh	1956	7700	3660		H		d 1	Kh 1)
» . . . . .	10	390	»	»	»	1955	»	»		»		»	» 1)
» . . . . .	11	391	»	»	»	»	»	»		»		»	» 1)
» . . . . .	12	392	1900	»	»	»	»	»		»		»	» 1)
» . . . . .	13	393	1899	»	»	1956	»	»		»		»	» 1)
» . . . . .	14	394	1883	Atlas	Ar	1943	7730	3960		»		d 2	Ar 1)
» . . . . .	15	395	1881	»	»	1944	»	»		»		»	» 1)
» . . . . .	18	398	1870	Launstein	»	1943	8510	4270		»		»	» 1)
» . . . . .	19	399	1879	Breslau	»	1944	7700	3660		»		»	» 1)
Kurverreguleringsvogn . . . . .	1	411			Ar	1949	9000	4200		H	0	Ar	Ar
» . . . . .	2	412	1898	Scandia	»	»	9870	4700		S	»	»	»
Malere, værkstedsvogn for . . . . .	1	451	1877	Breslau		1911	9000	4200		H		Kh	Kh

1) Må ikke benyttes i tog på banestrækningen.

Maskinarbejdere, værkstedsv. for	1	456	1886	Breslau		1917	9580	4570		TL H	0	Cvk Kh	Kh
» » »	3	457	1885	»	Kh	1952	8500	4270	12	» »	El-stik	«	»
» » »	4	458	1886	Scandia	Ar	1956	8480	»		» RS	0	Cvk Ar	Ar
Maskintjenesten, værkstedsv. for	2	462	1905	Scandia	Kh	1949	9800	5000		TL S		Gb	Kh
» » »	3	463	»	»	»	»	»	»		» »		»	»
» » »	4	464	1924	Görlitz	»	1954	11700	6000	30	» RS	El-stik	»	»
» » »	7	467	1876	Randers	»	1955	9000	4116	12	», P	L, 0	»	»
» » »	8	468	1901	Scandia	»	1958	8110	3660	»	» RS		Av	»
Opmålingsvogn . . . . .	1	491	1897	Görlitz	Kh	1948	9980	4700		TL H	El-stik 0	Kh	Kh

Benævnelse	Nr.	Special- vogns nr.	Bygge- år	Fabrikations- sted	Ombygget		Længde o. puff. mm	Aksel- afstand mm	Vogn- vægt t	Bremse	Lys Varme	Hjem- sted	Vk omr.
					Vk	år							
Signaltjenesten, værkstedsvogn for	1	501	1885	Atlas	Ar	1939	10190	4874		TL RS		Es	Ar
» » »	2	502	1880	Scandia	Kh	1936	»	»		» »		Gl	Kh
» » »	4	504	»	»	Ar	1930	»	»		» »		Str	Ar
» » »	5	505	1896	Strømmen	»	1931	»	»		» »	0	Ar	»
» » »	6	506	1898	Scandia	»	1951	9870	4700	12	» H	»	Te	Ar
» » »	7	507	1893	»	Kh	1937	10190	4874		» RS		Hk	Kh
» » »	8	508	1885	Breslau	Ar	1946	8730	4270	12	» H		Hr	Ar
» » »	9	509	1897	Strømmen	»	1931	10190	4874		» RS		Sl	»
» » »	10	510	1906	»	»	1955	10700	5700	12	» H	0	Ab	»
» » »	11	511	1881	Kochum	»	1931	10190	4874		» RS		Hr	»
» » »	12	512	1896	Strømmen	»	1935	»	»		» »		Fa	»
» » »	13	513	1915	»	Kh	1955	12990	7220	15	» »	El-stik 0	Kb	Kh
» » »	16	516	1897	Strømmen	»	1936	10190	4874		» »	»	Kj	»
» » »	18	518	1870	Elbing	Ar	1939	7330	3960		» H		Ab	Ar
» » »	19	519	1884	Breslau	Ng	1951	»	»		» »		Svg	Ng
» » »	21	521	1873	Wagenbau	Ar	1926	»	»		» »		Od	»
» » »	22	522	1897	Strømmen	»	1938	10190	4874		» »		Ar	Ar
» » »	23	523	1873	Wagenbau	»	1926	7330	3960		» »		Ab	»
» » »	25	525	1877	Breslau	Ng	1931	7700	3660		» »		Str	»
» » »	26	526	1875	Wagenbau	Ar	1926	7330	3960		» »		Hj	»
» » »	27	527	1902	Strømmen	»	1951	7700	3660		» »		Ar	»
» » »	29	529	1881	Atlas	»	1926	7330	3960		» »		Va	»
» » »	33	533	1883	»	»	1929	7370	»		» »		Hr	»
» » »	34	534	1881	»	»	»	7330	»		» »		Rå	»
» » »	35	535	1885	Breslau	»	1935	9380	4420		» »	0	Sl	»
» » »	36	536	1881	Kockum	»	1931	10190	4874		» RS		Hr	»
» » »	37	537	1885	Atlas	»	1934	»	»		» »		Ar	»
» » »	38	538	1881	Kockum	»	»	»	»		» H		Ab	»
» » »	39	539	»	»	»	»	»	»		» RS		Fa	»
» » »	40	540	1880	Scandia	»	»	»	»		» »		»	»

Signaltjenesten, værkstedsvogn for	41	541	1881	Kochum	Ar	1936	10190	4874		TL	RS		Sl	Ar		
»	»	»	43	543	1897	Strømmen	Kh	1937	»	»	»	»	Kh	Kh		
»	»	»	45	545	»	»	Ar	1938	»	»	»	»	Str	Ar		
»	»	»	49	549	1880	Scandia	Kh	1939	»	»	»	»	Ba	Kh		
»	»	»	50	550	1885	Atlas	»	»	»	»	»	»	Bav	»		
»	»	»	51	551	1896	Strømmen	»	»	»	»	»	»	Nf	»		
»	»	»	52	552	»	»	»	»	»	»	»	»	Fb	»		
»	»	»	53	553	1883	Atlas	Ar	»	7330	3960	»	H	Gi	Ar		
»	»	»	54	554	1922	Scandia	Kh	1949	12210	6350	13	»	El-stik 0	Hl	Kh	
»	»	»	55	555	1876	Randers	Ar	1944	9000	4116	»	»	»	Vj	Ar	
»	»	»	56	556	1886	Scandia	»	»	8440	4270	»	»	»	Tdr	»	
»	»	»	57	557	1870	Lauenstein	»	»	8510	»	»	»	»	Bb	»	
»	»	»	58	558	1907	Scandia	Kh	1949	12220	6500	12	»	El-stik	Sg	Kh	
»	»	»	59	559	1905	»	»	»	10700	5700	»	»	»	Kl	»	
»	»	»	60	560	»	»	»	»	11360	6000	»	»	»	Hi	»	
»	»	»	61	561	1880	»	Ar	1946	8730	4270	»	»	»	Hr	Ar	
»	»	»	63	563	1892	Cassel	»	1950	11370	7000	»	RS	El-stik	Sdb	»	
»	»	»	65	565	1885	Atlas	Ng	1946	10480	5000	»	H	0	Od	Ng	
»	»	»	66	566	»	»	Ar	1948	10700	5700	12	»	»	»	»	
»	»	»	67	567	1882	Scandia	»	1949	8990	4270	»	»	»	»	»	
»	»	»	68	568	1876	Breslau	Ng	1950	9000	4200	»	»	»	Ng	»	
»	»	»	69	569	1884	»	Ar	1946	»	»	12	TL	»	0	Str	Ar
»	»	»	70	570	1887	Scandia	»	1947	»	»	»	»	»	»	Te	»
»	»	»	71	571	»	»	»	1948	10700	5700	12	»	»	»	Bm	»
»	»	»	72	572	»	»	»	1950	9320	4200	»	»	»	»	Te	»
»	»	»	73	573	1898	Scandia	»	»	9870	4700	»	»	»	»	Str	»
»	»	»	75	575	1914	»	Kh	1952	13500	8000	15	»	RS	El-stik	Rg	Kh
»	»	»	76	576	1913	»	»	»	»	»	»	»	»	»	Næ	»
»	»	»	77	577	1924	»	»	1956	13070	»	»	»	»	»	Hg	»
»	»	»	78	578	»	»	»	»	»	»	»	»	»	»	Gb	»
»	»	»	79	579	»	»	»	1957	»	»	»	»	»	»	Ro	»



Benævnelse	Nr.	Special- vogn nr.	Bygge- år	Fabrikations- sted	Ombygget		Længde o. puff. mm	Aksel- afstand mm	Vogn- vægt t	Bremse	Lys Varme	Hjem- sted	Vk omr.
					Vk	år							
Signalvæsen, værkstedsvogn for ..	1	611	1884	Breslau	Kh	1947	10880	6040		TL H	El-stik 0	Fb	Kh
» » » ..	2	612	»	»	»	»	»	»		» »	» »	Sg	»
Sikringsanlægskolonne, mandskabsvogn for ..	5	620	1886	Skabo	Kh	1952	10600	5000	12	TL H	El-stik 0	Val	Kh
værkstedsvogn for ..	1	611	1907	Scandia	»	1949	11730	6300	»	» RS	» »	»	»
» » » ..	2	622	»	»	»	»	»	»	»	» »	» »	»	»
» » » ..	3	623	»	»	»	»	»	»	»	» »	» »	»	»
» » » ..	4	624	1877	Hamburg	»	1950	8630	4250	»	» »	» »	»	»
» » » ..	6	626	1913	Scandia	»	1953	13500	8000	15	» »	» »	»	»
Slamvogn .....	1	641	1899	Breda	Kh	1936	5800	3000		RS		Ro	Kh
» .....	2	642	1882	Borsig	Ar	1937	»	»		»		Næ	»
» .....	3	643	1899	Breda	Kh	1940	»	»		»		Nf	»
» .....	4	644	1901	Borsig	»	1953	5720	»		TL »		Kø	»
» .....	5	645	»	Breda	»	1954	»	»		» »		Gb	»

Sprøjtevoغن (ukrudt) .....	1	661	1893	Scandia	Kh	1929	10190	4876		TL	S			Kh	
» » .....	2	662	1870	Peacock	Ar	»	6520	2 × 1428			RS			Ar	
» » .....	3	663	1886	Schwartzkopff	»	»	6370	1280+1525			»			»	
» » .....	4	664	1896	Hartmann	»	1950	6120	2 × 1600			»			»	
» » .....	5	665	1901	Linden	»	1951	»	»			»			»	
Svejsevoغن .....	5	675	1886	Breslau	Kh	1952	9580	4570	12	TL	H	El-stik	0	Gb	Kh
» .....	6	676	1917	Scandia	Ar	1943	10630	5200		»	»	»	»	Ar	Ar
» .....	7	677	1911	»	»	1944	»	»		»	»	»	»	Fa	»
» .....	9	679	1877	Breslau	Kh	1952	9000	4200	12	»	»	El-stik	»	Gb	Kh
» .....	10	680	1915	Scandia	»	1957	13070	8000		»	RS	»	»	»	»
» .....	11	681	1901	»	Ar	1946	10630	5200	10	»	H	»	»	Ar	Ar
» .....	13	683	1913	»	»	1956	13500	8000		»	»	»	»	Fa	»
» .....	14	684	1886	Skabo	»	1953	8500	4270	10	»	»	»	»	»	»
» .....	16	686	1914	Scandia	Kh	»	13500	8000	15	TL	RS	El-stik	»	Kh	Kh
» .....	17	687	1923	»	Ar	1957	»	»		»	H	»	»	Ar	Ar
» .....	18	688	1914	»	»	»	»	»		»	»	»	»	Fa	»
» .....	19	689	1913	»	»	»	»	»		»	»	»	»	»	»
» .....		690	1924	»	»	1958	14400	9000	16	»	»	»	»	»	»
» .....	22	692	1923	»	Kh	»	13070	8000	15	»	RS	El-stik	»	Kh	Kh
» .....	25	695	1884	Breslau	»	1947	10880	6040	12	»	H	»	»	»	»
» .....		696	1924	Scandia	Ar	1958	14400	9000	16	»	»	»	»	Fa	Ar
» .....		697	1924	«	»	»	»	»	16,5	»	RS	El-stik	»	»	»
» .....	29	699	1915	»	»	1955	12990	7220		»	»	»	»	»	»
» .....	33	673	1880	Scandia	Kh	1948	10900	6050		»	H	El-stik	»	Kh	Kh

Benævnelse	Nr.	Special- vogns nr.	Bygge- år	Fabrikations- sted	Ombygget		Længde o. puff. mm	Aksel- afstand mm	Vogn- vægt t	Bremse		Lys Varme	Hjem- sted	Vk omr.
					Vk	år								
Svellestoppemaskine, værkstedsvogn for...	1	721	1886	Scandia	Kh	1950	10880	6040	12	TL	H	El-stik 0	Ro	Kh
« « « ..	3	723	1914	«	Ar	1956	13500	8000		«	RS	« «	Ar	Ar
« « « ..	4	722	«	«	«	1957	«	«		«	H	« «	«	«
« « « ..		724	1924	«	«	1958	14400	9000	16	«	RS	«	«	«
Telefonkolonnen, værkstedsvogn for...	2	742	1885	Breslau	Ar	1954	8500	4270	12	TL	S	0	Ng	Ng
« « « ..	3	743	1883	Kockum	«	«	«	«	«	«	«	«	«	«
« « « ..	4	744	1923	Scandia	Kh	1958	13070	8000	15	«	RS	El-stik «	Fb	Kh
Togforvarmningsvogn .....	2	402	1913	Scandia	Ar	1958	9490	5000	14	TL	H		Str	Ar
Traktorvogn .....	1	746	1877	Wagenbau	Kh	1929	7700	3660			RS		Aat	Ar

vognopsynet, værkstedsvogn for . .	2	772	1879	Zypen	Ar	1944	7700	3660		TL	RS	0	Ar	Ar
« « « ..	4	774	1911	Scandia	Kh	1955	10630	5200	15	TB	S	«	Kø	Kh
« « « ..	5	775	1926	«	«	«	«	«	«	«	«	«	Gb	«
« « « ..	7	777	1917	«	«	«	«	«	«	«	«	«	Ro	«
« « « ..	8	778	«	«	«	1956	«	«	«	«	«	«	Ge	«
« « « ..	9	779	1880	Breslau	Ar	1957	8230	4200		TL	RS	«	Fa	Ar
Vægtsmede, værkstedsvogn for . .	1	791	1883	Breslau	Ng	1937	9000	4200			H	0	Ng	Ng
« « « ..	2	792	1888	Scandia	«	1947	10490	5000		TL	«	«	«	«
« « « ..	3	793	1887	«	«	1945	10630	5200		«	«	«	«	«
« « « ..	4	794	1899	«	«	1944	«	«		«	«	«	«	«
« « « ..	5	795			«	1956	12990	7220		«	S	«	«	«



## International litrering af DSB-godsvogne

### Litra E

- E** = Højsidede vogne af gængs type, kan tippes over enden eller siden. Last 20 t eller mere.

### Litra Gs

- G** = Lukkede vogne af gængs type med 8 ventilationsåbninger eller flere. Læsselængde 8 m eller mere. Last 20 t eller mere.
- S** = Vognen er S-mærket d. v. s. må befordres i tog, hvis højeste hastighed er 100 km/t.

### Litra Hs-t

- H** = Lukkede vogne af speciel type.
- S** = Vognen er S- mærket.
- t** = Nationalt litra for forskydelige sidevægge.

### Litra Ks

- K** = Flade 2-akslede vogne af gængs type. Læsselængde 12 m eller mere og med bevægelige sider og aftagelige støtter. Last 20 t eller mere.
- S** = Vognen er S-mærket.

(Uddrag af midlertidig vedtaget UIC fiche 438)

*København i december 1961*

**Generaldirektoratet**

