

DAMPLOKOMOTIVET  
OG DETS BETJENING

PLANER



DAMPLOKOMOTIVET

OG DETS BETJENING





DE DANSKE STATSBANER  
MASKINAFDELINGEN

# DAMPLOKOMOTIVET OG DETS BETJENING

LÆREBOG FOR LOKOMOTIVPERSONALET

II. PLANER

4. UDGAVE

*Udarbejdet af*  
**VILHELM VOLDMESTER**  
*Afdelingsingeniør, cand. polyt.*  
*Maskinafdelingen.*

KØBENHAVN

---

1948



## INDHOLDSFORTEGNELSE

Plan	Fig.	Plan	Fig.	Plan	Fig.
1	1—11	38	96—98	75	193
2	12—16	39	99—103	76	194—194a
3	17—23	40	104—108	77	195—197
4	24—28	41	109—110	78	198—201
5	29—30	42	111—111a	79	202—205
6	31	43	112	80	206—209
7	32	44	113—114	81	210—211a
8	33	45	115—116	82	212—213
9	34	46	117	83	214
10	35	47	118	84	215—217
11	36	48	119—123	85	218—223
12	37	49	124—126a	86	224—224b
13	38	50	127—129	87	225—225b
14	39	51	130	88	225c—226
15	40	52	131	89	227—230
16	41	53	132—137	90	231—234
17	42—43	54	138—139	91	235
18	44—45	55	140a	92	236—236a
19	46—47	56	140b—140c	93	237—238b
20	48	57	141	94	239
21	49	58	142—144	95	240—243
22	50	59	145—148	96	244—246
23	51—52	60	149—154	97	247—247c
24	53—56	61	155	98	248—250
25	57—62	62	156—159	99	251—252
26	63—66	63	160—163	100	253
27	67—73	64	164—167a	101	254—257
28	74	65	168—169	102	258—262
29	75	66	170—173	103	263—266
30	76	67	174—177	104	267—268
31	77—78	68	178—180	105	269—269a
32	79—81	69	181—182	106	270—274
33	82	70	183—184a	107	275—280
34	83	71	185—188	108	281—283
35	84—86	72	189—190	109	284—288
36	87—92	73	191	110	289—290
37	93—95	74	192	111	291—292



Plan	Fig.	Plan	Fig.	Plan	Fig.
112	293—293b	134	320	156	358—359
113	294	135	321	157	360
114	295	136	321 forts.	158	361
115	296	137	322a—323	159	362—363
116	297	138	324	160	364—365
117	298	139	325a—325b	161	366
118	299	140	326—327	162	367
119	300	141	328—329	163	367a—369
120	301	142	330—333	164	370
121	302	143	334	165	371—372
122	303	144	334 forts.	166	373—376
123	304—304a	145	335—337	167	377—380
124	305—306	146	338	168	381—384
125	307	147	339	169	385
126	307a	148	340—342	170	386—388c
127	308—309	149	343—345b	171	389—393
128	310—311	150	346—348	172	394—399
129	312	151	349	173	400—405
130	313	152	350	174	406—410
131	314—316	153	351—352	175	411—413
132	317a—318	154	353—354	176	414—417
133	319	155	355—357		

## PLANER



PLAN 1

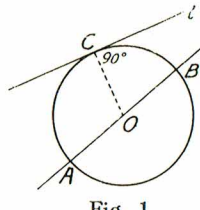

Fig. 1

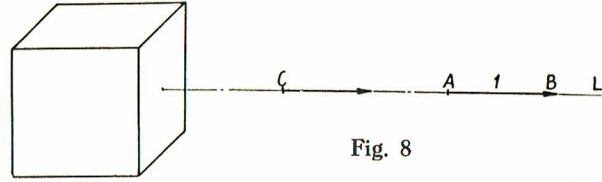

Fig. 8

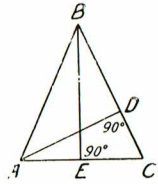

Fig. 2

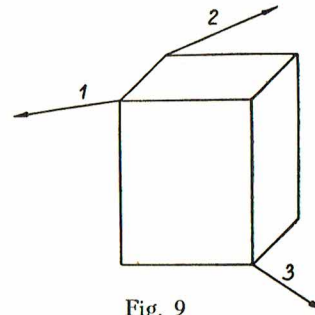

Fig. 9

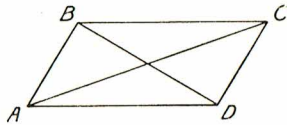

Fig. 3

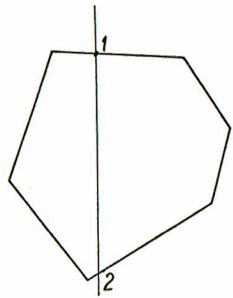

Fig. 10

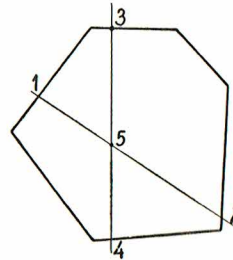

Fig. 11

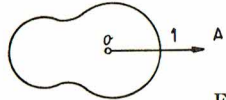

Fig. 4

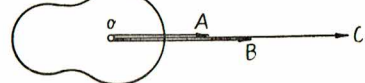

Fig. 5

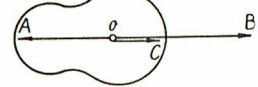

Fig. 6

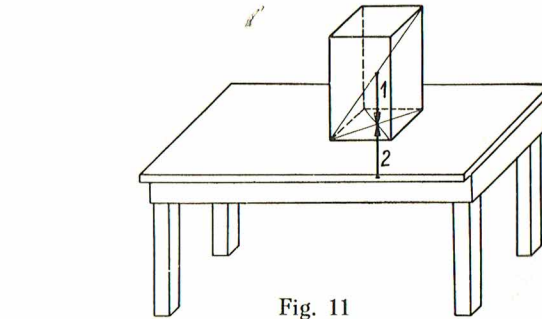
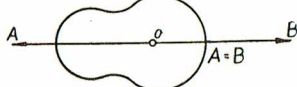

Fig. 11

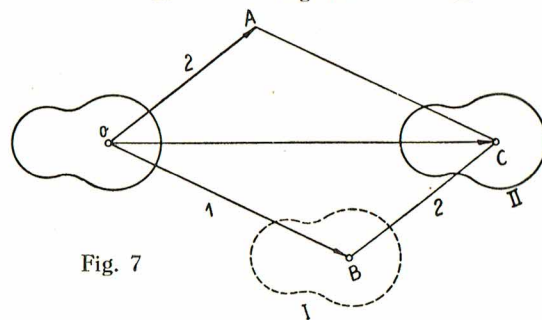
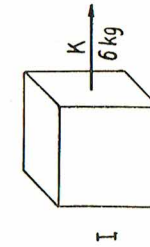

Fig. 7

Fig. 1—11

PLAN 2

$$\frac{K}{H} = \frac{6}{3} = 2$$



I

$$\frac{2K}{2H} = \frac{12}{6} = 2$$

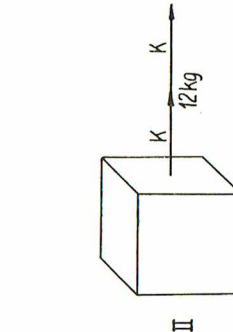

II

$$\frac{3K}{3H} = \frac{18}{9} = 2$$

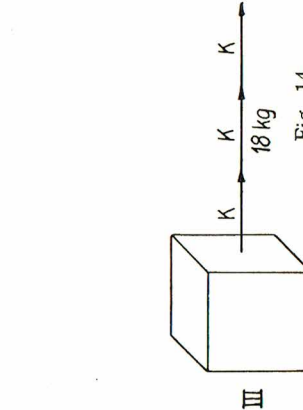

III

Fig. 14

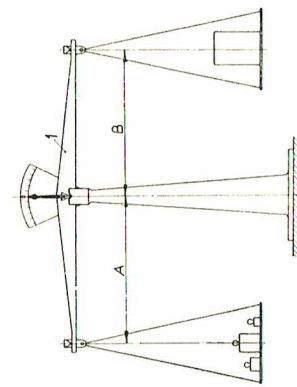

Fig. 12

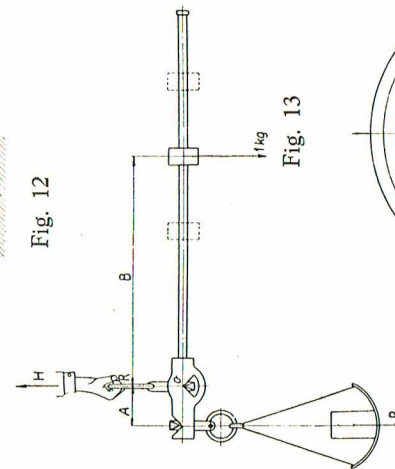

Fig. 13

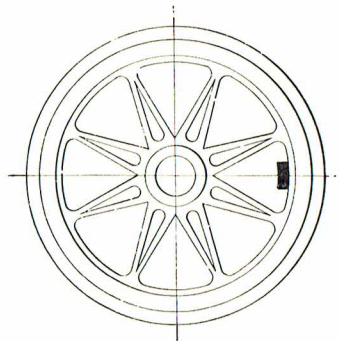

Fig. 15

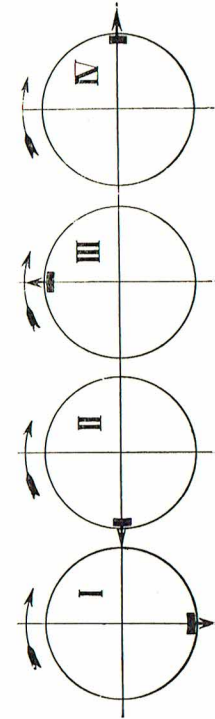

Fig. 16

Fig. 12—16



Fig. 17—23

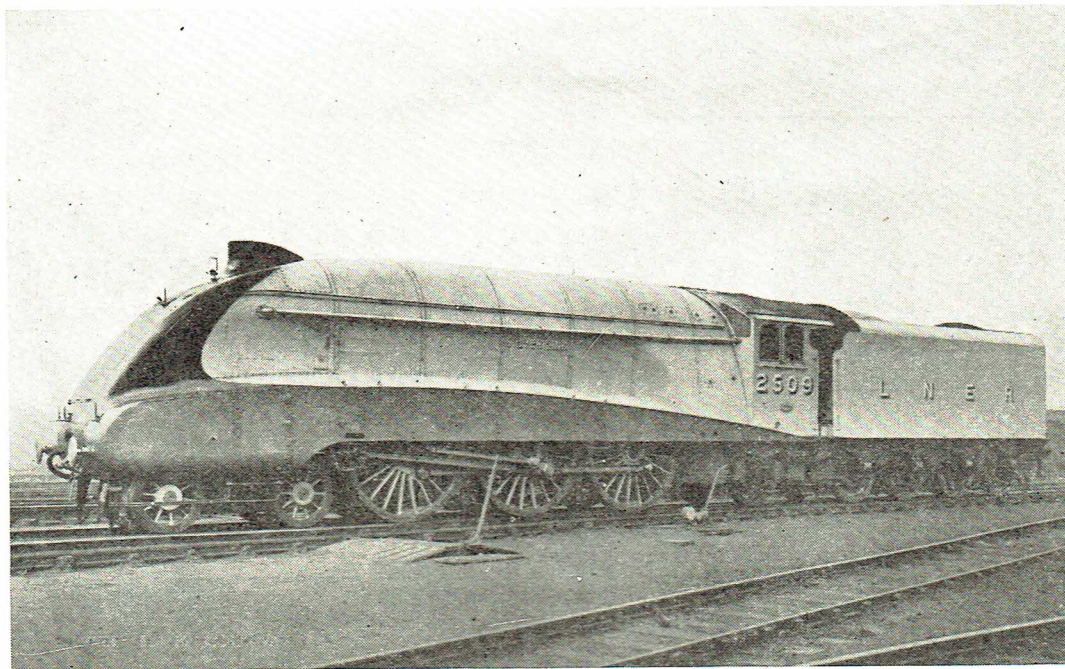

Fig. 17

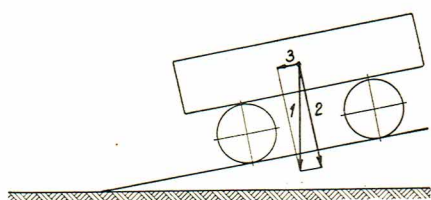

Fig. 18

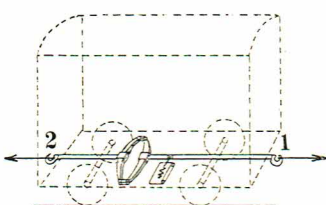

Fig. 19

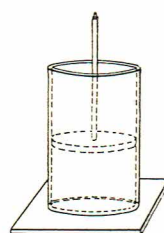

Fig. 23

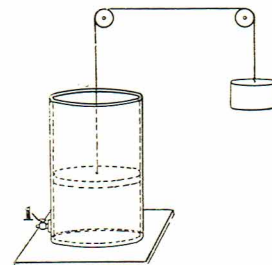

Fig. 20

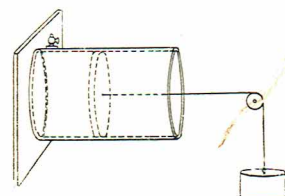

Fig. 21

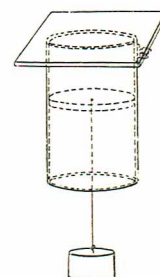

Fig. 22

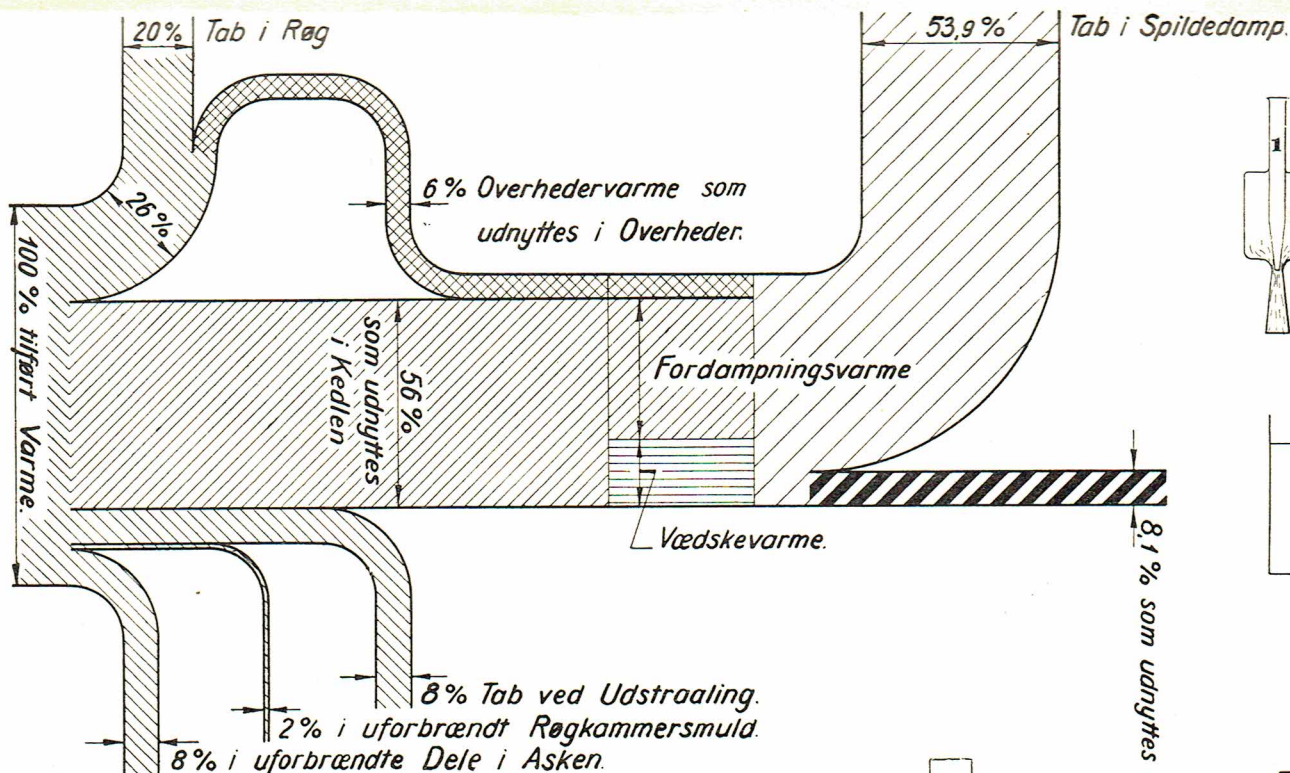

Fig. 28

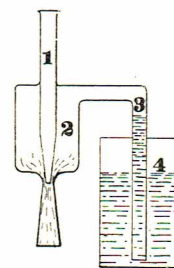

Fig. 24

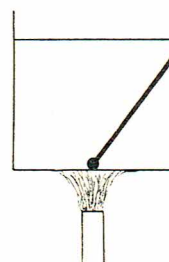

Fig. 26 a

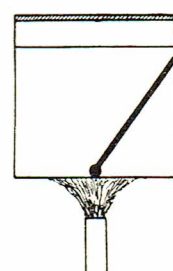

Fig. 26 b

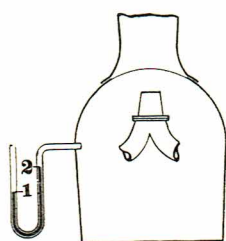

Fig. 25

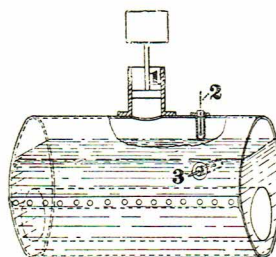

Fig. 27

Fig. 24—28



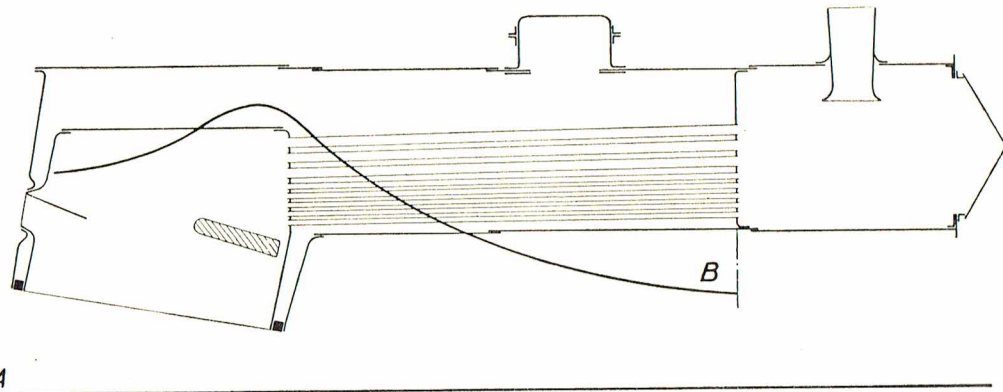

Fig. 29

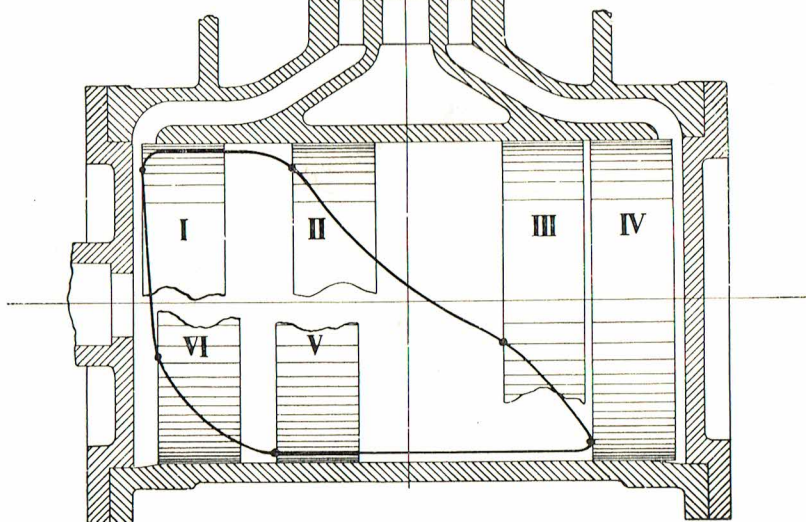
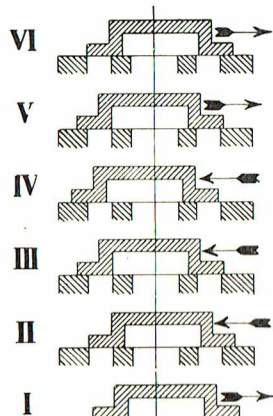

Fig. 30

Fig. 29—30

PERSONTOGSLOKOMOTIV  
LITRA E

Byggeaar 1914—1947.

Antal Cylindre .....	2 HT og 2 LT
Styring .....	Heusinger
Cylinderdiameter .....	HT: 420 mm LT: 630 mm
Slaglængde .....	660 mm
Drivhjulsdiameter .....	1896 mm
Kedeltryk .....	13 kg pr. cm <sup>2</sup>
Overheder .....	System Schmidt
Ildberørt Hedeflade ....	184,7 m <sup>2</sup>
Overheder-Hedeflade ...	63,6 m <sup>2</sup>
Risteflade total .....	3,6 m <sup>2</sup>
Adhæsvægt .....	54 t
Lokomotivets Vægt	
tjenstfærdig .....	88,4 t
Tenderens Vægt	
tjenstfærdig .....	55,2 t
Tenderens Beholdning af:	
Kul .....	6,5 t
Vand .....	25,0 t
Maksimalhastighed .....	100 km pr. Time

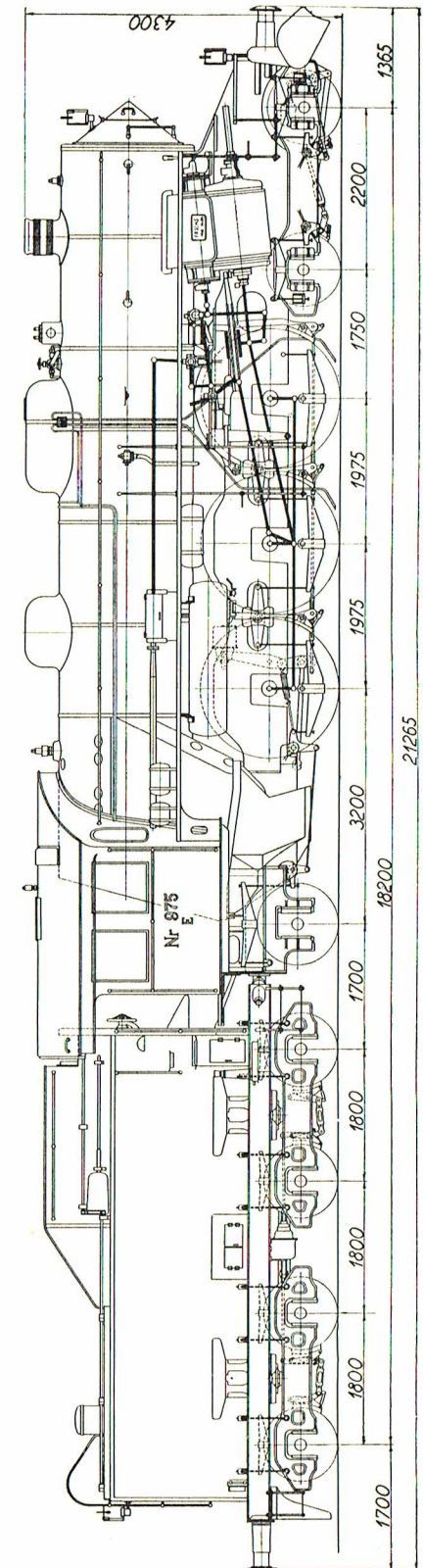

Fig. 31

Fig. 31 1 : 100







PERSONTOGSLOKOMOTIV  
LITRA Pr  
Bygget 1943—

Antal Cylindre .....	2 HT og 2 LT
Styring .....	Heusinger
Cylinderdiameter .....	HT: 360 mm LT: 600 mm
Slaglængde .....	640 mm
Drivhjulsdiameter .....	1730 mm
Kedeltryk .....	13 kg pr. cm <sup>2</sup>
Overheder .....	System Schmidt
Ildberørt Hedeflade ....	150,0 m <sup>2</sup>
Overheder-Hedeflade ...	46,6 m <sup>2</sup>
Risteflade total .....	2,6 m <sup>2</sup>
Adhæsvægt .....	48,0 t
Lokomotivets Vægt tjenstfærdig .....	78,6 t
Tenderens Vægt tjenstfærdig .....	52,0 t
Tenderens Beholdning af:	
Kul .....	6,0 t
Vand .....	23,0 t
Maksimalhastighed .....	100 km pr. Time

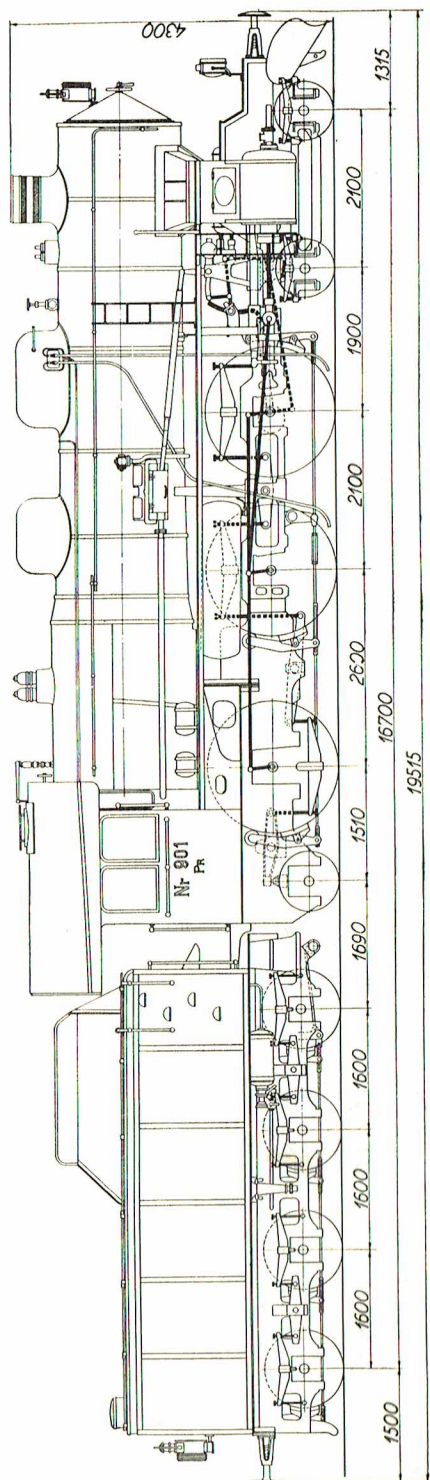

Fig. 34 1 : 100

Fig. 34

PERSONTOGSLOKOMOTIV  
LITRA S  
Byggeaar 1924—1928.

Antal Cylindre .....	3
Styring .....	Heusinger
Cylinderdiameter .....	430 mm
Slaglængde .....	670 mm
Drivhjulsdiameter .....	1730 mm
Kedeltryk .....	12 kg pr. cm <sup>2</sup>
Overheder .....	System Schmidt
Ildberørt Hedeflade ....	118,2 m <sup>2</sup>
Overheder-Hedeflade ...	46,0 m <sup>2</sup>
Risteflade total .....	2,4 m <sup>2</sup>
Adhæsvægt .....	50,7 t
Lokomotivets Vægt tjenstfærdig .....	98,6 t
Lokomotivets Beholdning af:	
Kul .....	4,0 t
Vand .....	10,0 t
Maksimalhastighed .....	90 km pr. Time

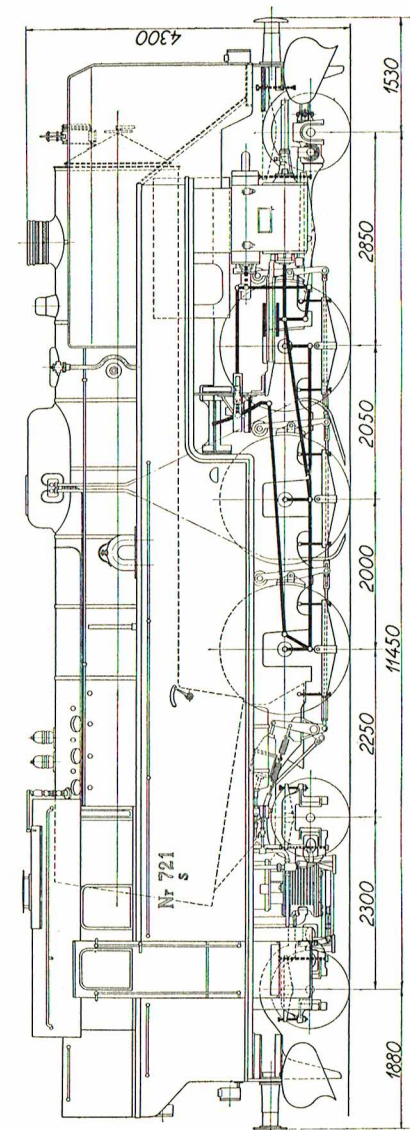

Fig. 35 1 : 100

Fig. 35





GODSTOGSLOKOMOTIV

LITRA H

Byggeaar 1941.

Antal Cylindre .....	3
Styring .....	Heusinger
Cylinderdiameter .....	470 mm
Slaglængde .....	670 mm
Drivhjulsdiameter .....	1404 mm
Kedeltryk .....	12 kg pr. cm <sup>2</sup>
Overheder .....	System Schmidt
Ildberørt Hedeflade ...	161,0 m <sup>2</sup>
Overheder-Hedeflade ...	55,0 m <sup>2</sup>
Risteflade total .....	2,6 m <sup>2</sup>
Adhæsvægt .....	68,0 t
Lokomotivets Vægt	
tjenstfærdig .....	81,3 t
Tenderens Vægt	
tjenstfærdig .....	57,0 t
Tenderens Beholdning af:	
Kul .....	8,0 t
Vand .....	27,0 t
Maksimalhastighed .....	80 km pr. Time

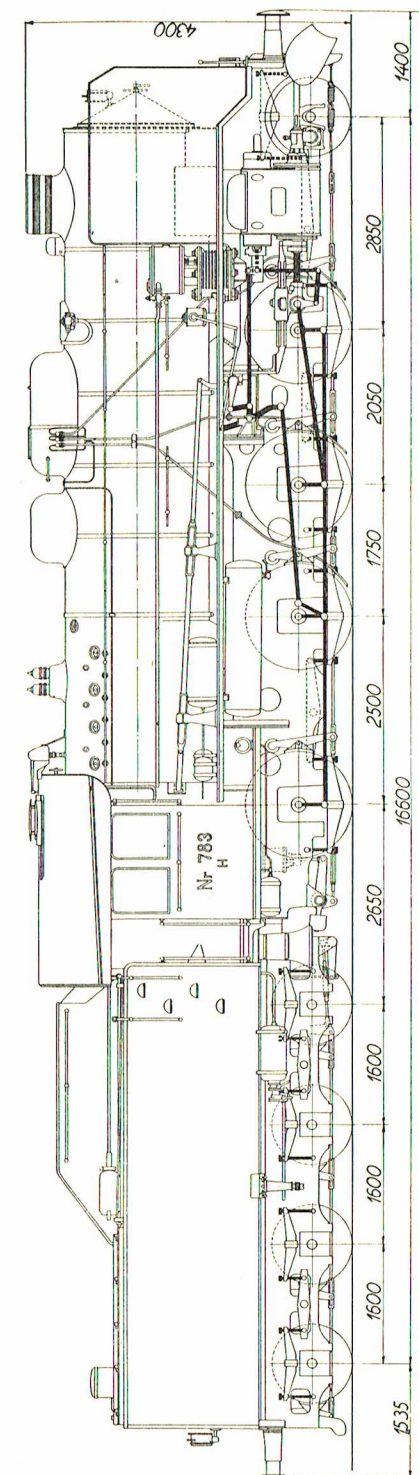

Fig. 37 1 : 100

Fig. 37



GODSTOGSLOKOMOTIV  
LITRA Div

Byggeaar 1925—1941.

Antal Cylindre . . . . .	2
Styring . . . . .	Heusinger
Cylinderdiameter . . . . .	460 mm
Slaglængde . . . . .	610 mm
Drivhjulsdiameter . . . . .	1404 mm
Kedeltryk . . . . .	12 kg pr. cm <sup>2</sup>
Overheder . . . . .	System Schmidt
Ildberørt Hedeflade . . . . .	78,7 m <sup>2</sup>
Overheder-Hedeflade . . . . .	23,4 m <sup>2</sup>
Risteflade total . . . . .	2,1 m <sup>2</sup>
Adhæsionsvægt . . . . .	38,8 t
Lokomotivets Vægt	
tjenstfærdig . . . . .	47,3 t
Tenderens Vægt	
tjenstfærdig . . . . .	28,0 t
Tenderens Beholdning af:	
Kul . . . . .	3,5 t
Vand . . . . .	11,0 t
Maksimalhastighed . . . . .	60 km*) pr. Time

\*) Maksimalhastigheden er forsøgsvis forhøjet til 70 km pr. Time.  
Lokomotiverne er fremstillede ved Ombygning af D1- og D11-Maskiner, der er bygget i Aarene 1902—1912.

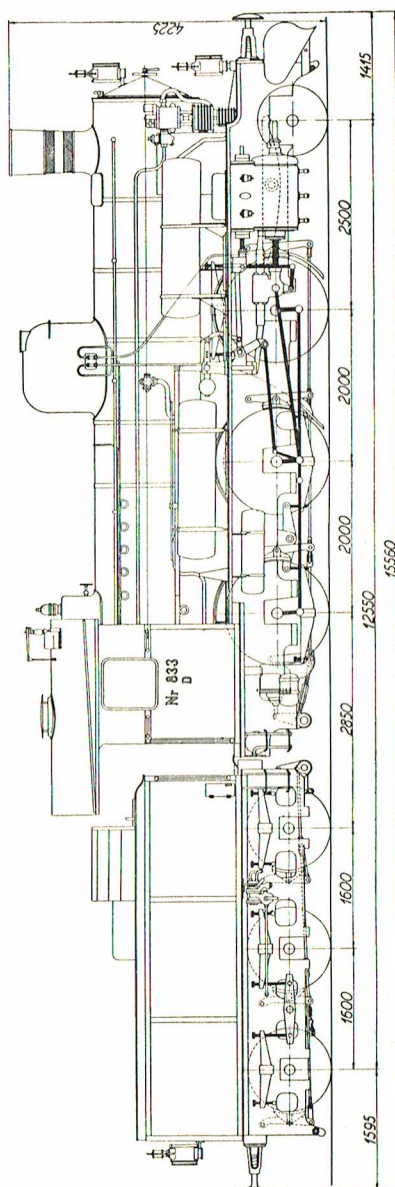

Fig. 38 1 : 100

Fig. 38

GODSTOGSLOKOMOTIV  
LITRA D11

Byggeaar 1912—1922.

Antal Cylindre . . . . .	2
Styring . . . . .	Heusinger
Cylinderdiameter . . . . .	460 mm
Slaglængde . . . . .	610 mm
Drivhjulsdiameter . . . . .	1404 mm
Kedeltryk . . . . .	12 kg pr. cm <sup>2</sup>
Overheder . . . . .	System Schmidt
Ildberørt Hedeflade . . . . .	85,3 m <sup>2</sup>
Overheder-Hedeflade . . . . .	22,5 m <sup>2</sup>
Risteflade total . . . . .	1,8 m <sup>2</sup>
Adhæsionsvægt . . . . .	36,4 t
Lokomotivets Vægt	
tjenstfærdig . . . . .	44,0 t
Tenderens Vægt	
tjenstfærdig . . . . .	28,0 t
Tenderens Beholdning af:	
Kul . . . . .	3,5 t
Vand . . . . .	11,0 t
Maksimalhastighed . . . . .	60 km*) pr. Time

Figuren viser Lokomotivet i den oprindelige Udførelse. Blandt de Ændringer, der senere er foretaget, kan særlig nævnes, at Vacuumbremsen er fjernet og erstattet af Trykluftbremse. Endvidere er Lokomotivet blevet forsynet med Trykluftsandingsapparat, Pop-Sikkerhedsventiler, Snenæser og Overheder, System Schmidt, ligesom Kulrummet i Tenderen fortil er blevet forhøjet med en Kasse paa lignende Maade som Tenderen i Fig. 38.

\*) Maksimalhastigheden er forsøgsvis forhøjet til 70 km pr. Time.

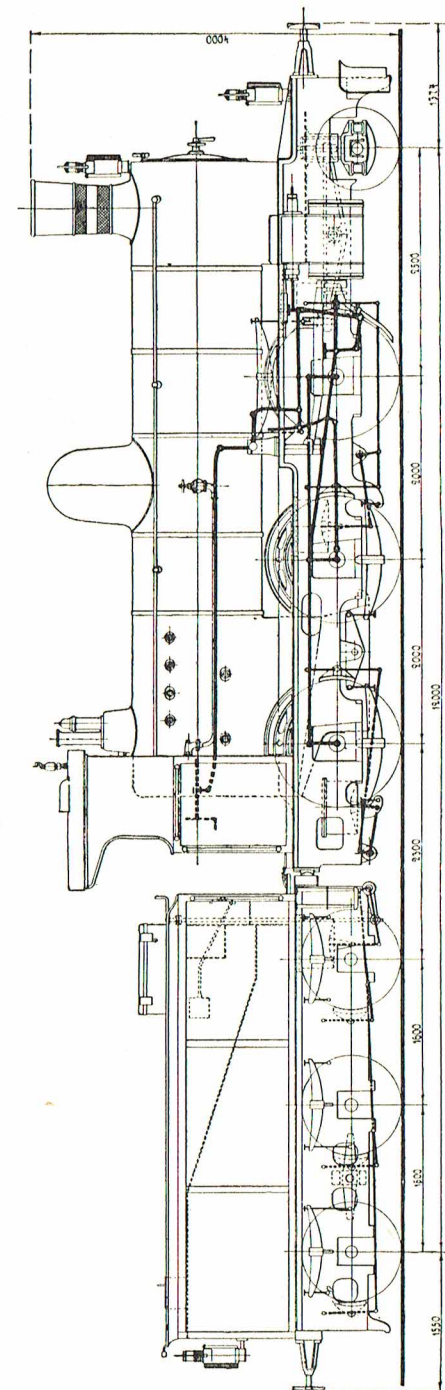

Fig. 39 1 : 80

Fig. 39

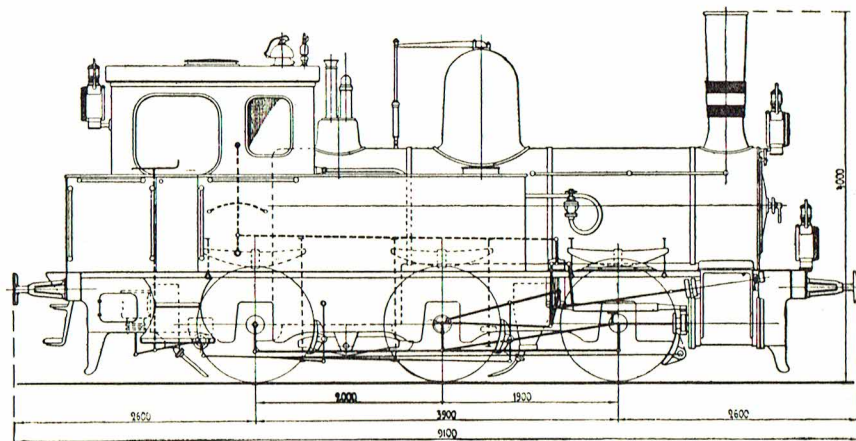

Fig. 40 1 : 80

RANGERLOKOMOTIV  
LITRA F<sub>II</sub>

Byggeaar 1898—1923.

Antal Cylindre . . . . .	2
Styring . . . . .	Trick
Cylinderdiameter . . . . .	406 mm
Slaglængde . . . . .	560 mm
Drivhjulsdiameter . . . . .	1252 mm
Kedeltryk . . . . .	12 kg pr. cm <sup>2</sup>
Ildberørt Hedeflade . . . . .	56,7 m <sup>2</sup>
Risteflade total . . . . .	1,0 m <sup>2</sup>
Adhæsionsvægt . . . . .	37,0 t
Lokomotivets Vægt	
tjenstfærdig . . . . .	37,0 t
Lokomotivets Beholdning	
af:	
Kul . . . . .	1,5 t
Vand . . . . .	3,5 t
Maksimalhastighed . . . . .	50 km pr. Time

Fig. 40

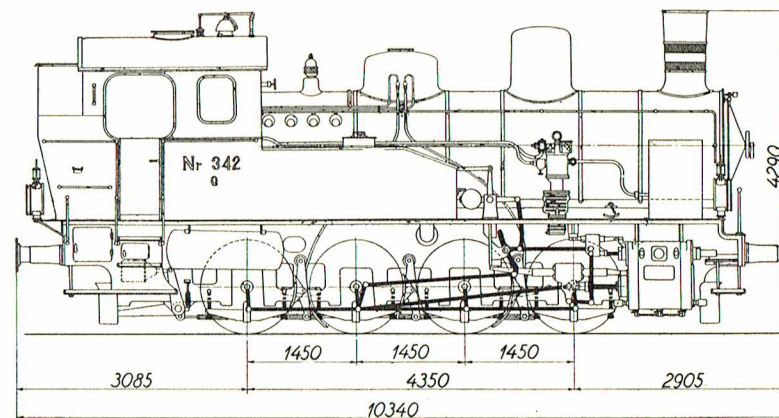

Fig. 41  
1 : 100

RANGERLOKOMOTIV  
LITRA Q

Byggeaar 1930—1945.

Antal Cylindre . . . . .	2
Styring . . . . .	Heusinger
Cylinderdiameter . . . . .	460 mm
Slaglængde . . . . .	610 mm
Drivhjulsdiameter . . . . .	1252 mm
Kedeltryk . . . . .	12 kg pr. cm <sup>2</sup>
Ildberørt Hedeflade . . . . .	101,6 m <sup>2</sup>
Risteflade total . . . . .	1,8 m <sup>2</sup>
Adhæsionsvægt . . . . .	56,0 t
Lokomotivets Vægt	
tjenstfærdig . . . . .	56,0 t
Lokomotivets Beholdning	
af:	
Kul . . . . .	2,5 t
Vand . . . . .	6,0 t
Maksimalhastighed . . . . .	30 km pr. Time

Fig. 41



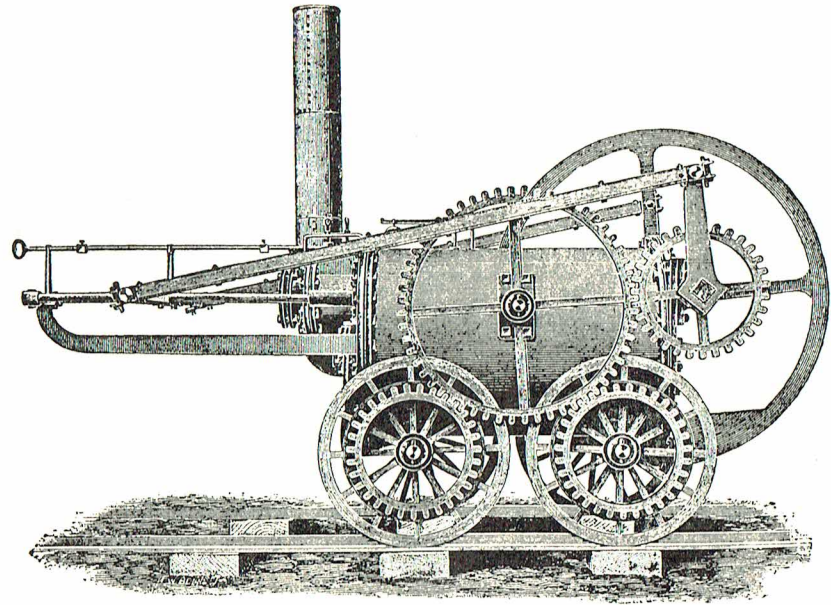

Fig. 42

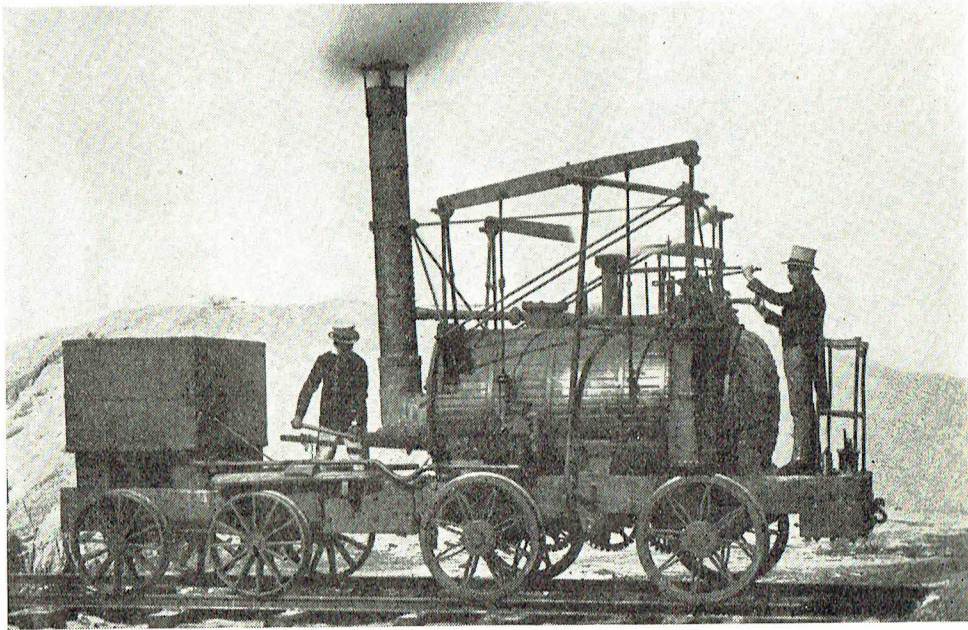
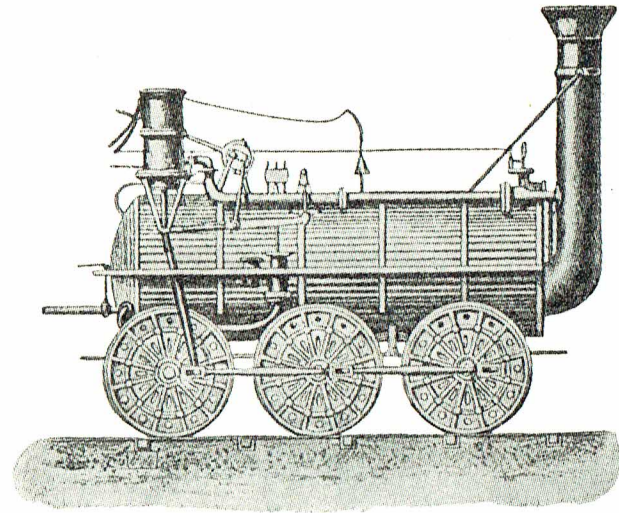

Fig. 43

Fig. 42—43



Hachworths ombyggede Lokomotiv fra 1827.

Fig. 44

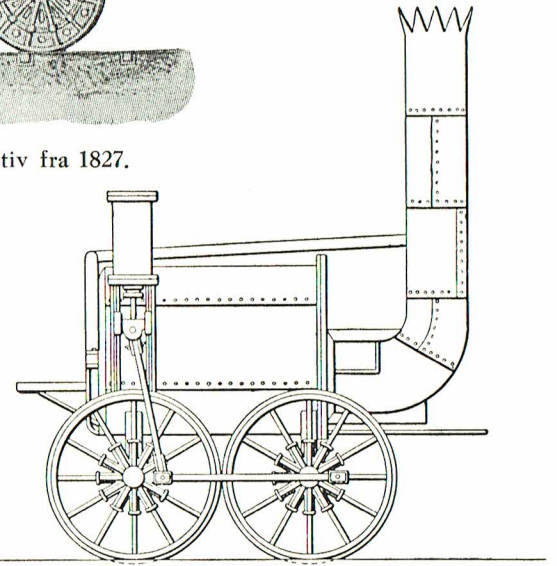

»Sanspareil« bygget af Hachworth 1829.

Fig. 45

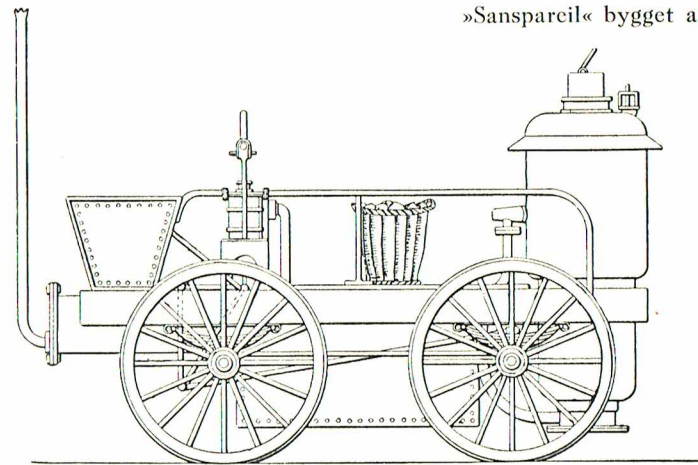

»Novelty« bygget af Braithwaite og John Ericson 1829.

Fig. 44—45



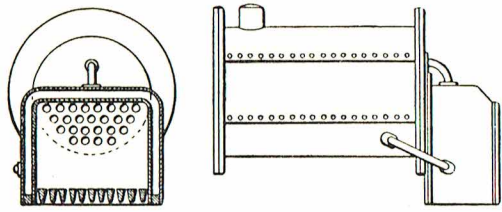

Kedlen til »Rocket«

Fig. 46

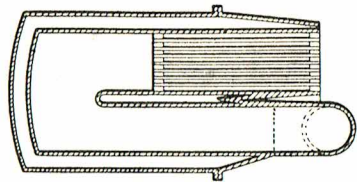

Kedlen til »Sanspareil«

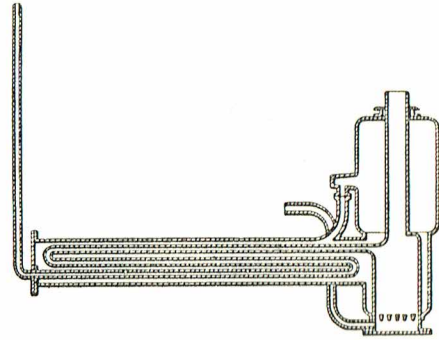

Kedlen til »Novelty«

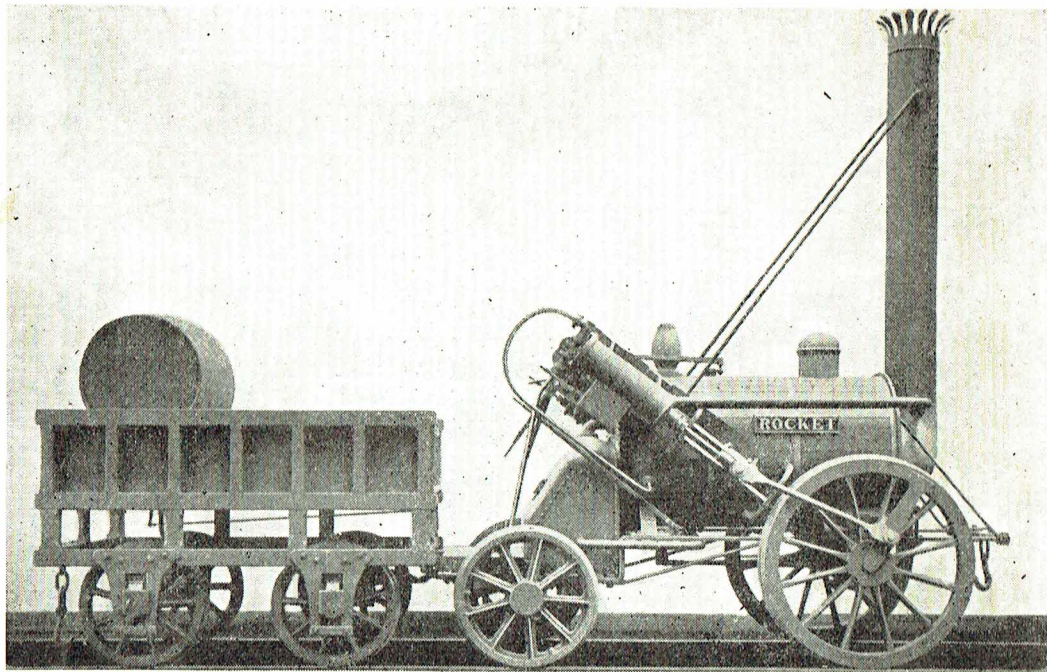

Fig. 47

Fig. 46—47

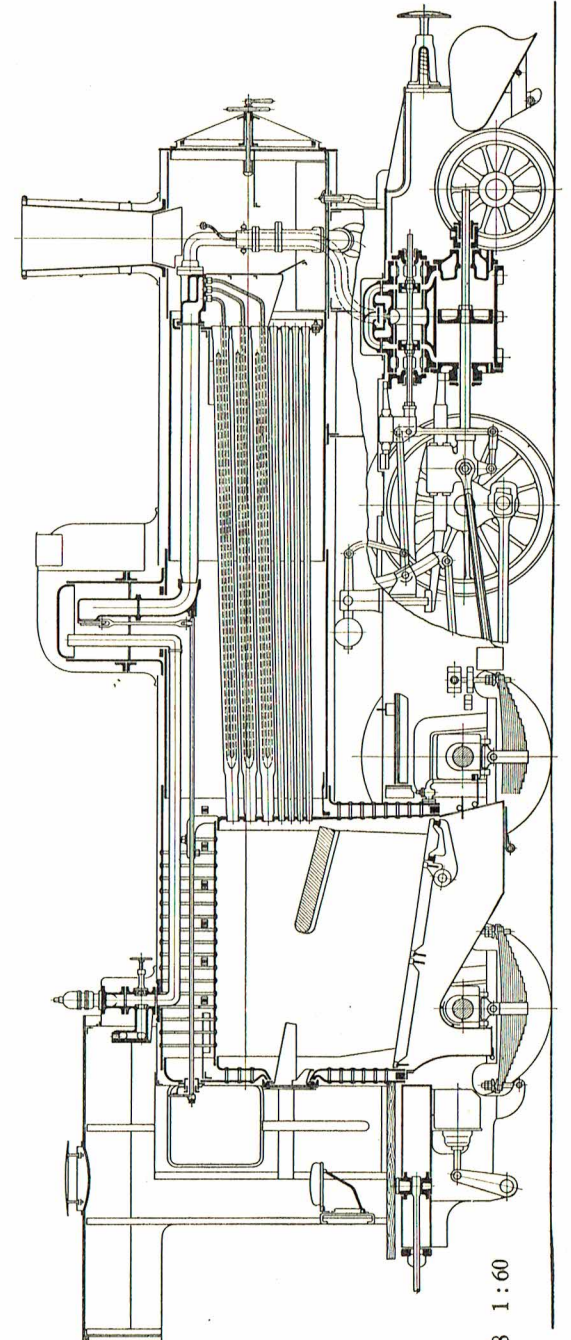
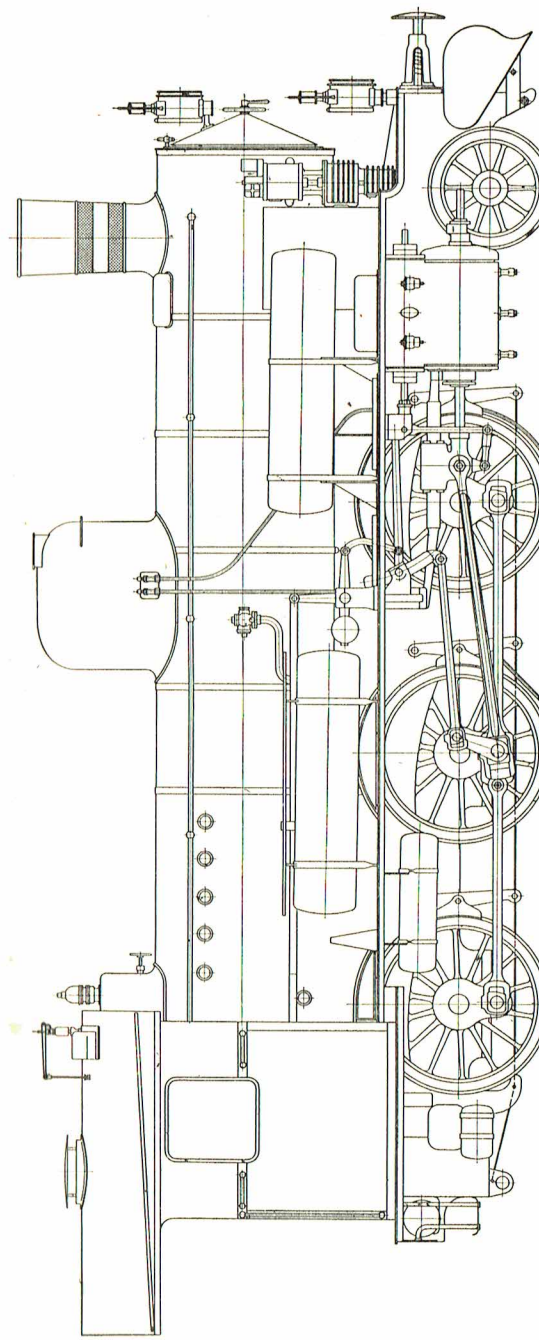

Fig. 48 1:60

Fig. 48



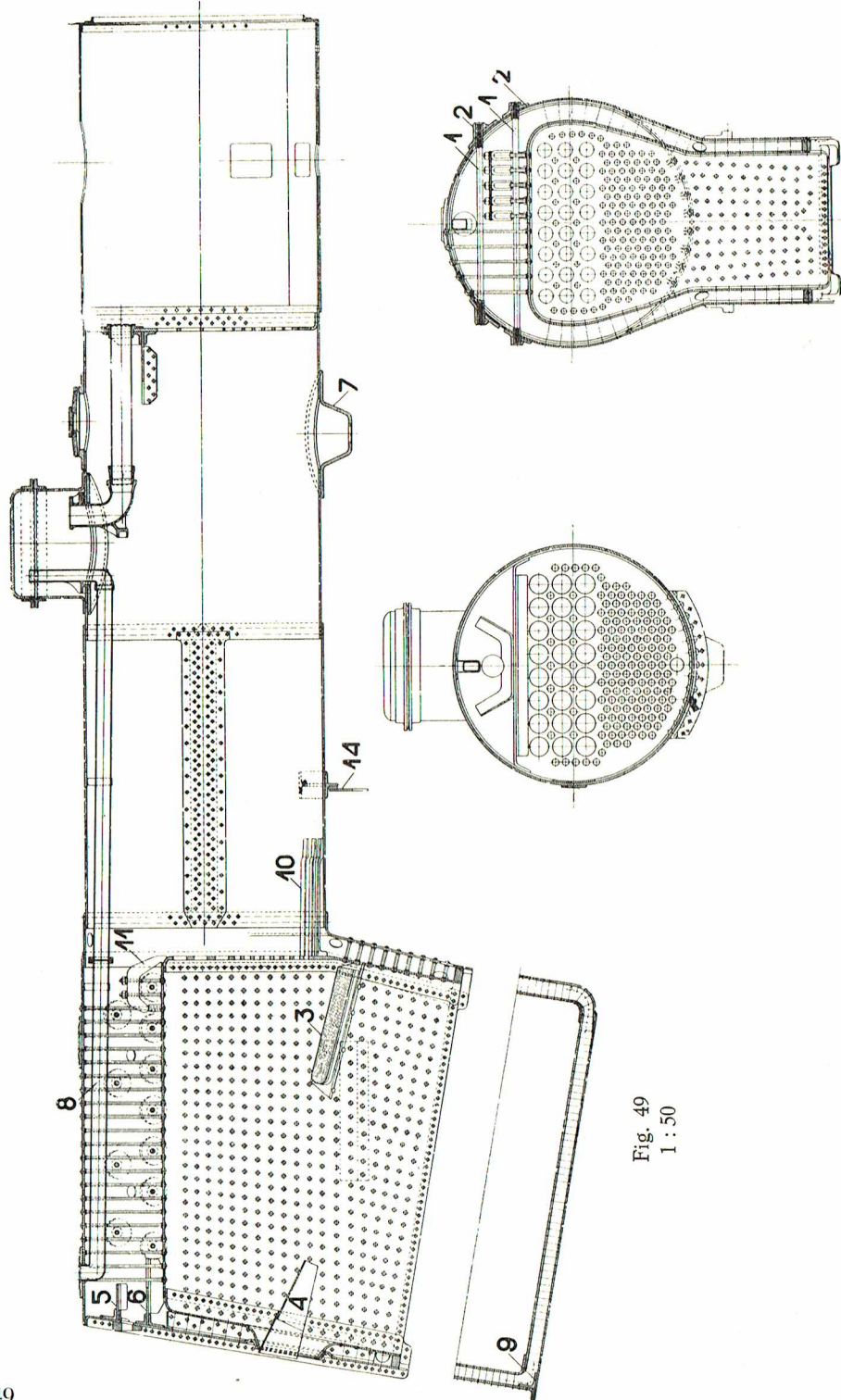

Fig. 49  
1 : 50

Fig. 49

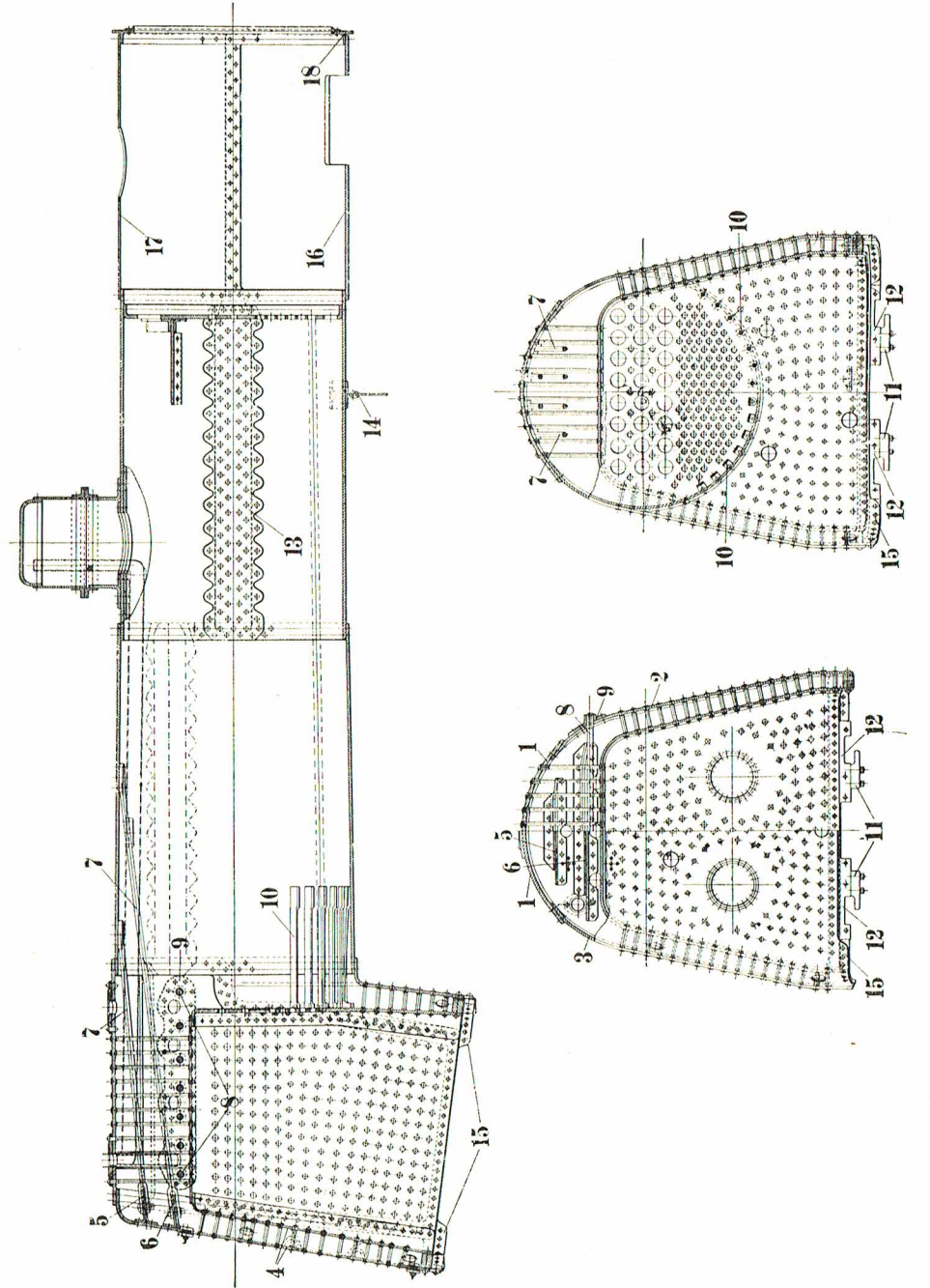

Fig. 50 1 : 50

Fig. 50

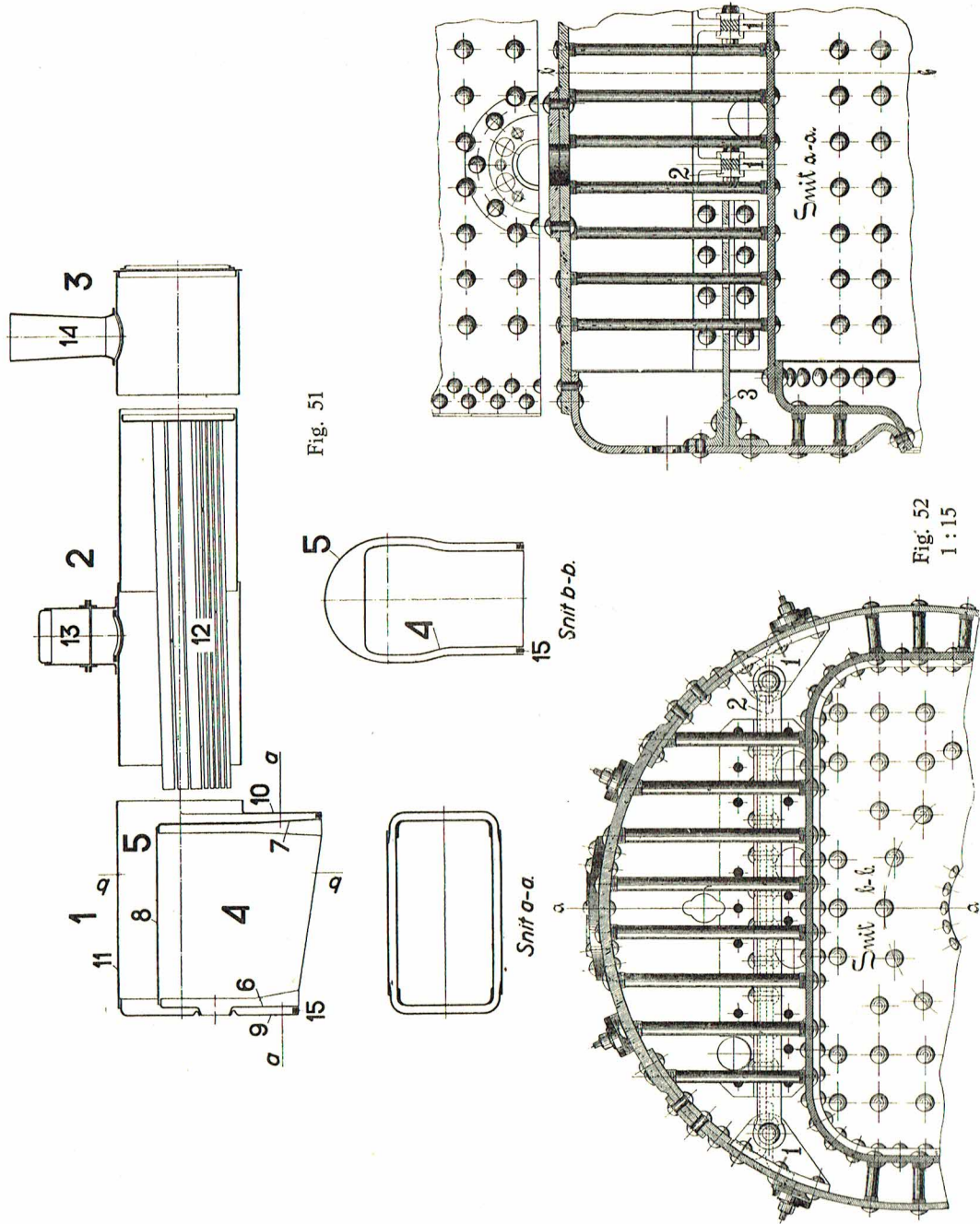

Fig. 51—52

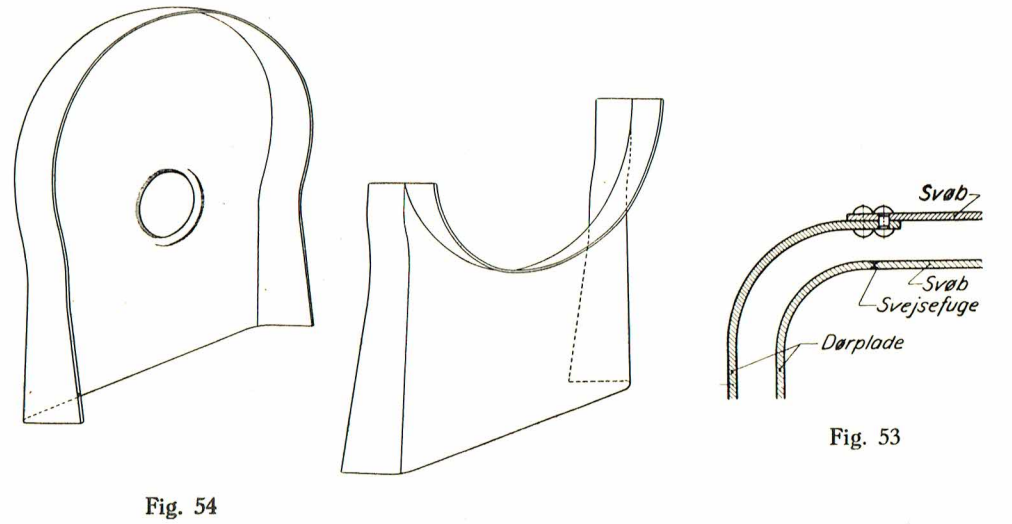

Fig. 54

Fig. 53

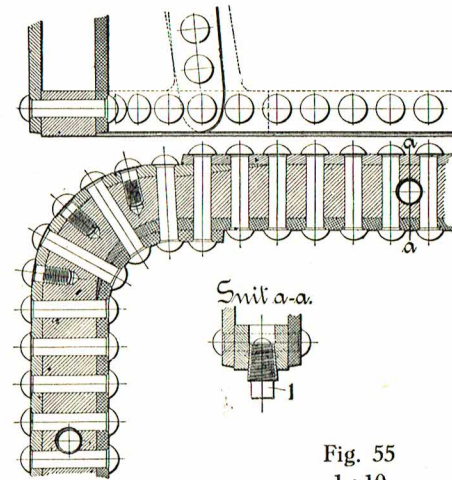

Fig. 55  
1 : 10

Fig. 56  
1 : 10



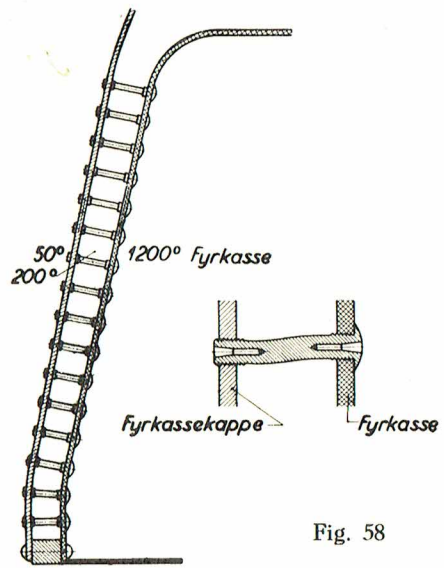

Fig. 58

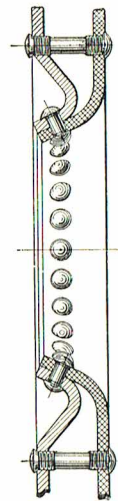

Fig. 57  
1:10

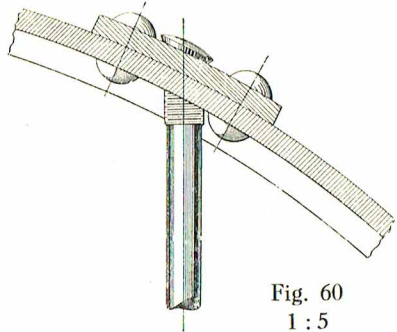

Fig. 60  
1:5

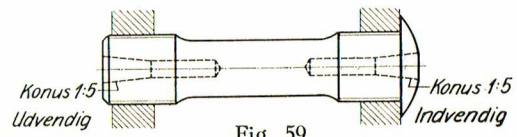

Fig. 59  
1:3

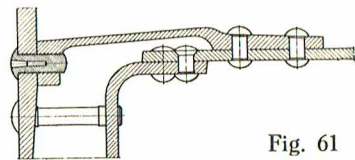

Fig. 61  
1:10

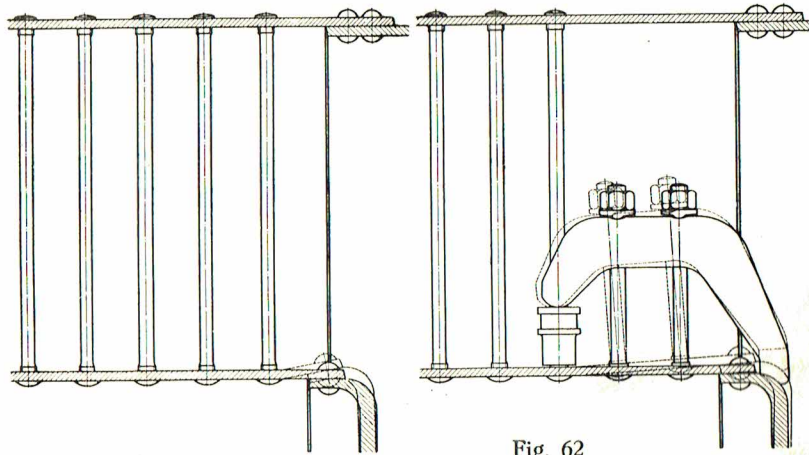

Fig. 62

Fig. 57—62

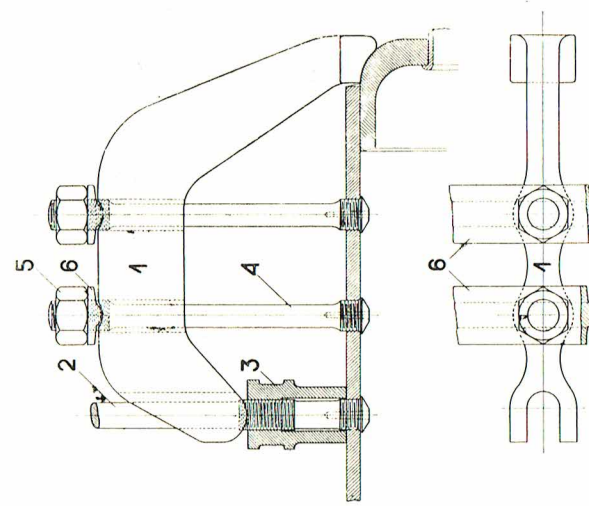

Fig. 63  
1:7,5

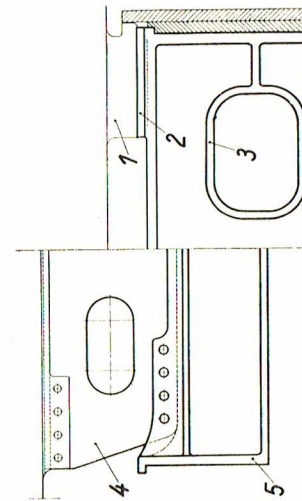

Fig. 65  
1:20

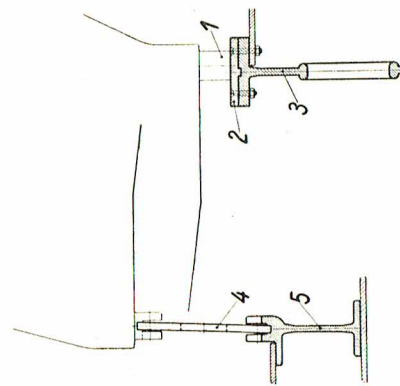

Fig. 66  
1:15

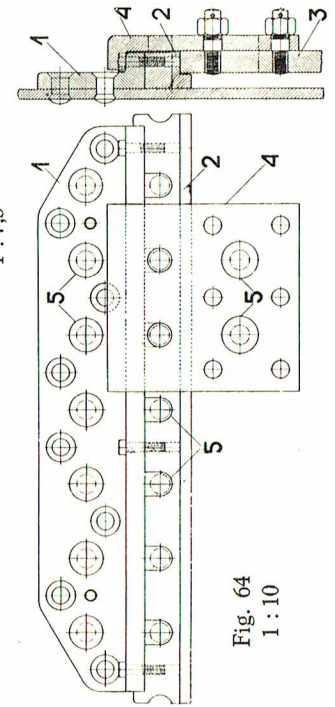

Fig. 64  
1:10

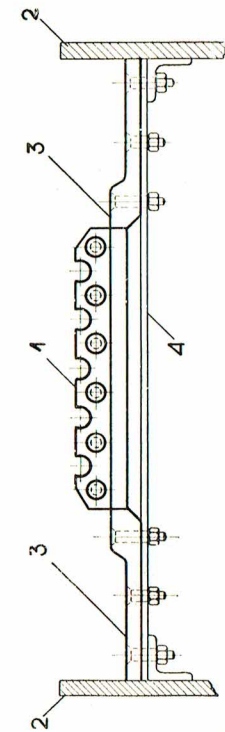

Fig. 63—66

Fig. 67-73

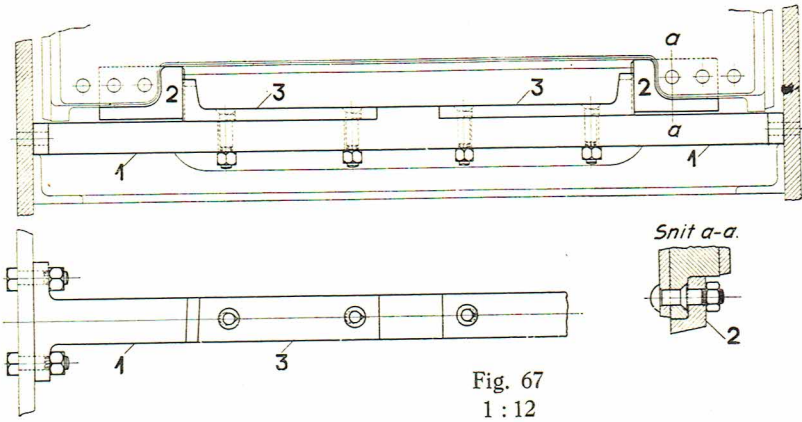

Fig. 67  
1:12

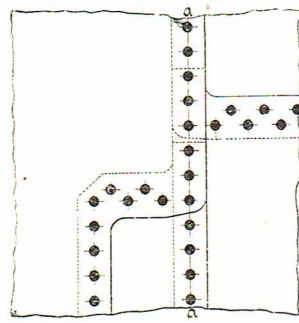

Fig. 68

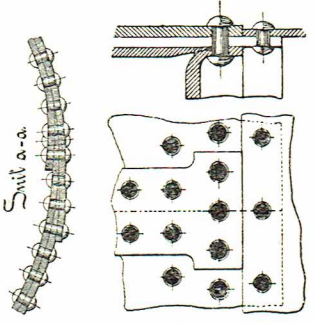

Fig. 70

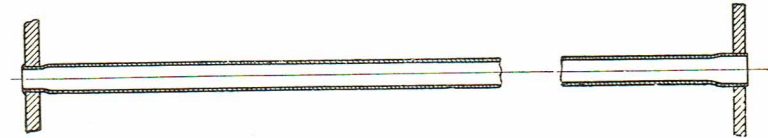

Fig. 72 1:12,5

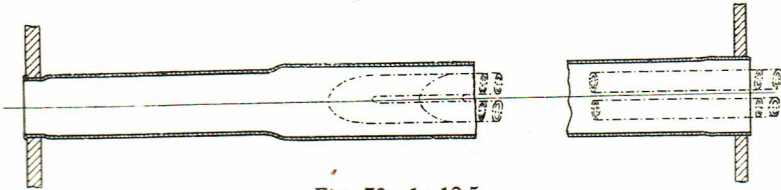

Fig. 73 1:12,5

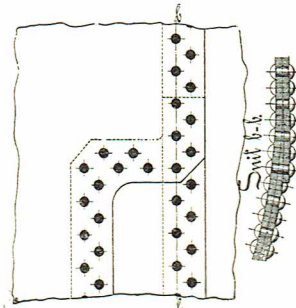

Fig. 69

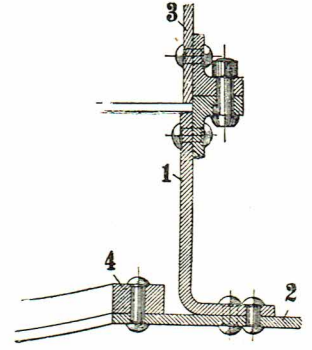

Fig. 71  
1:10

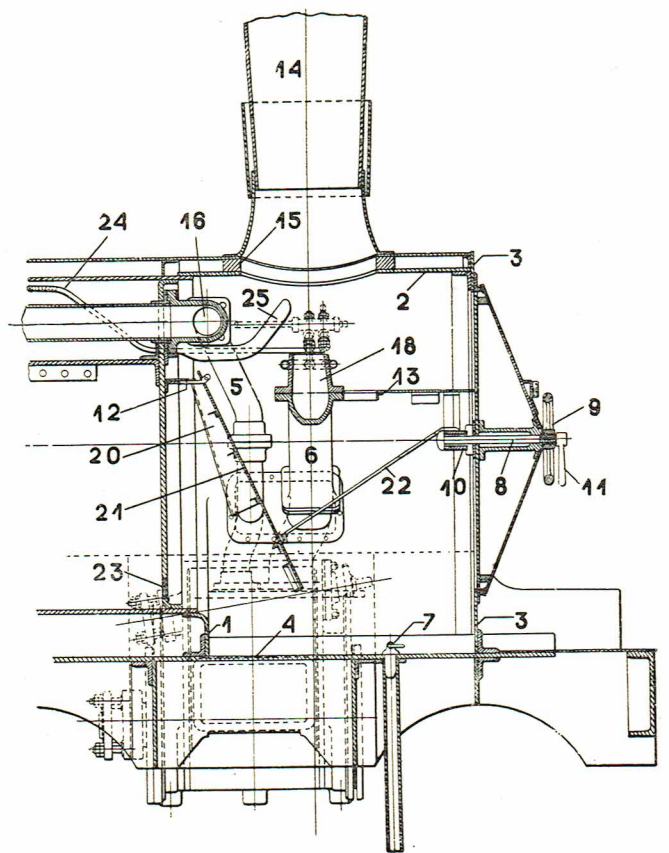
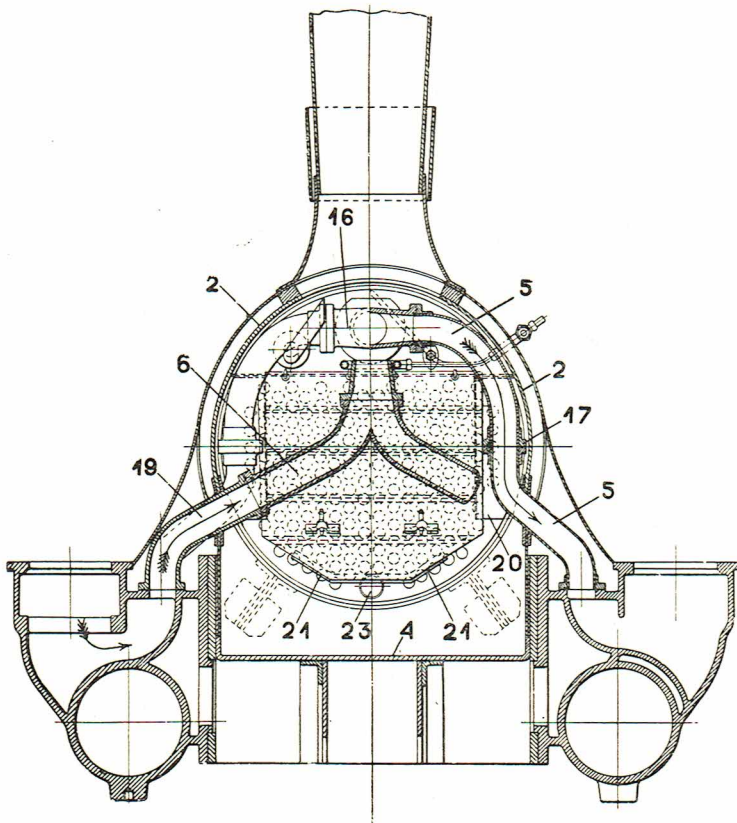

Fig. 74 1:30

Fig. 74



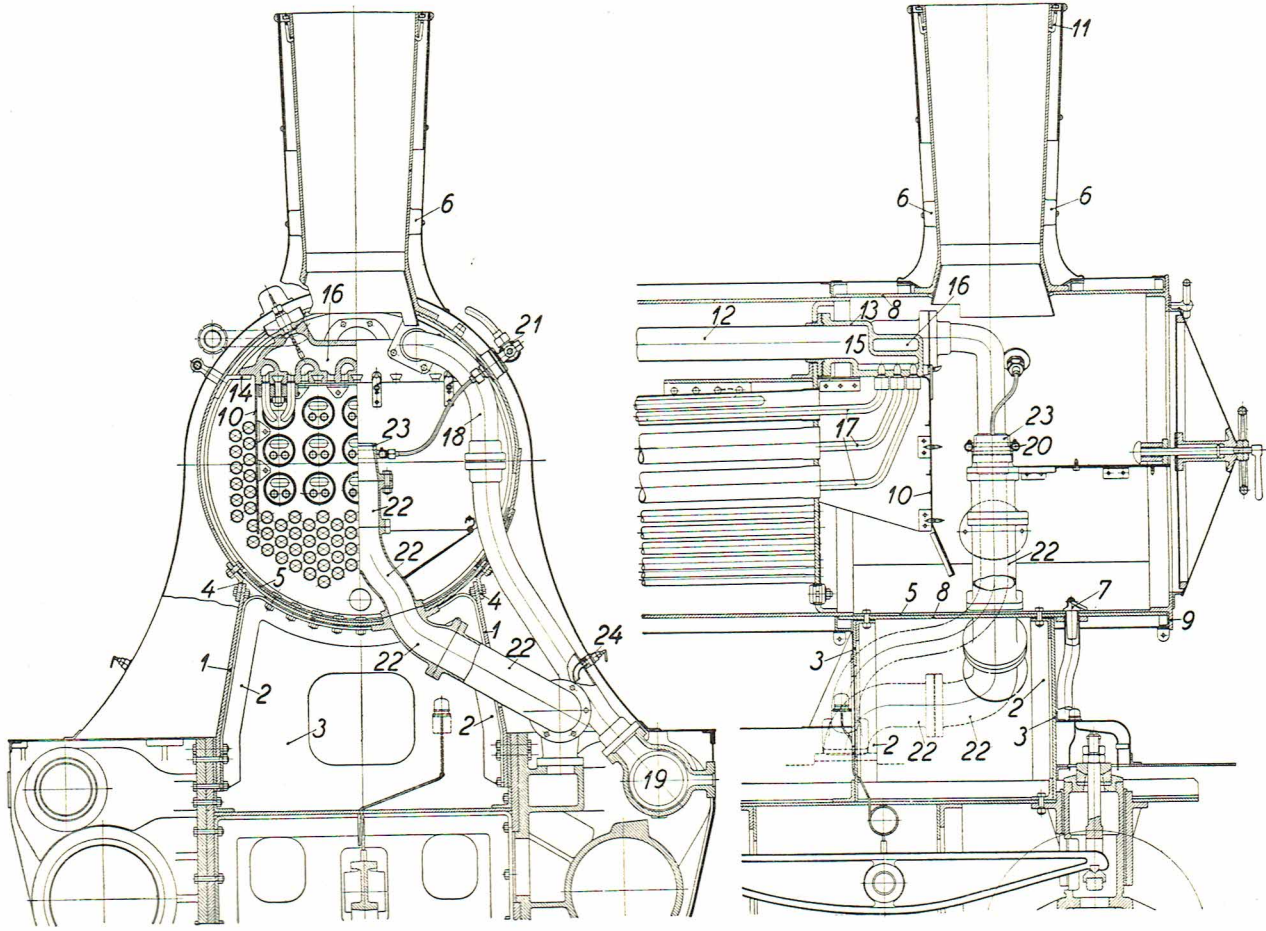

Fig. 75 1:30

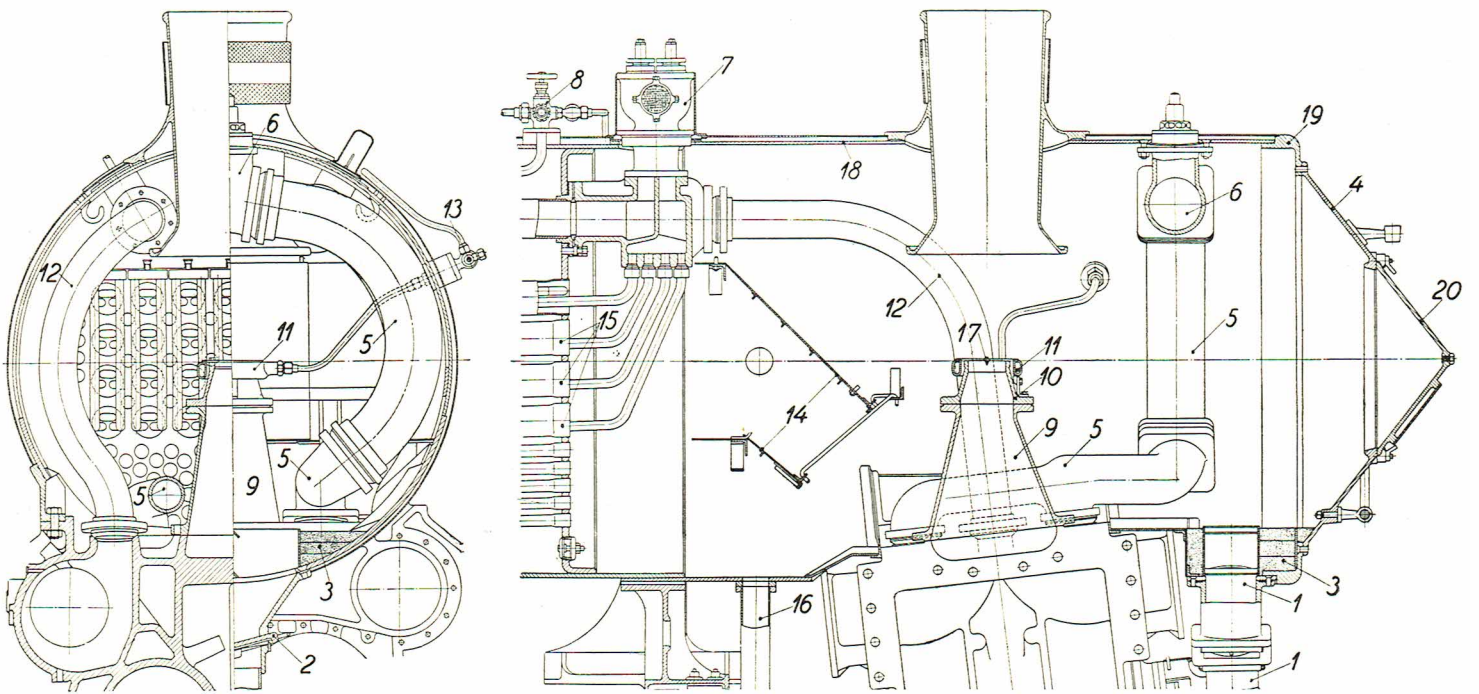

Fig. 76 1:30

Fig. 77-78

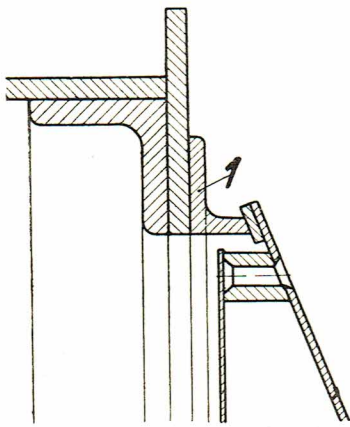

Fig. 77 1:5

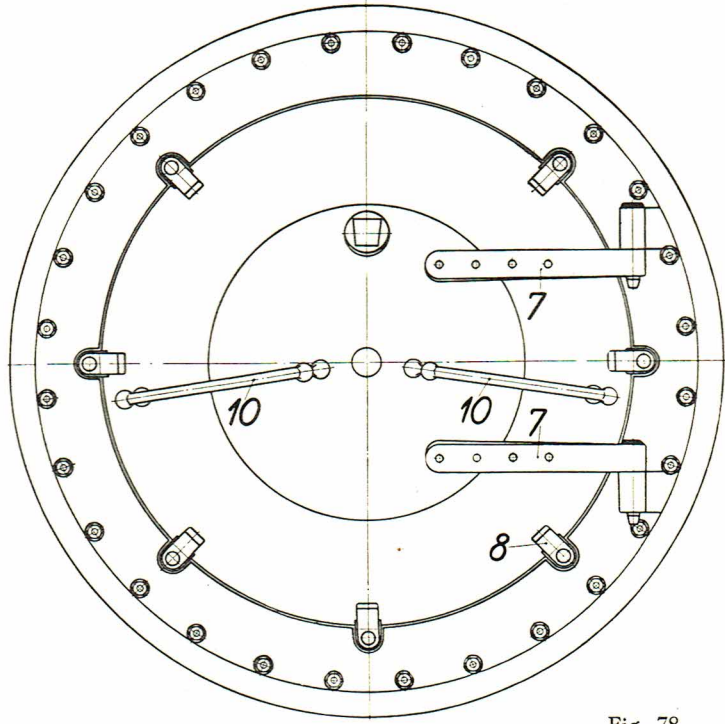

Fig. 78 1:20

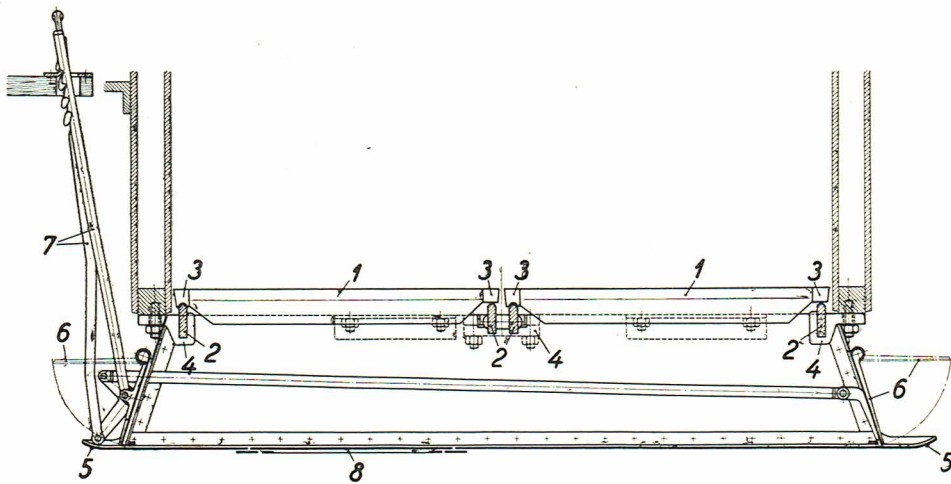
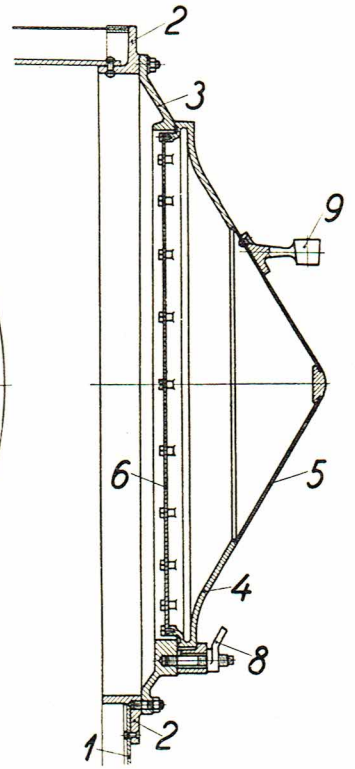

Fig. 79 1:20

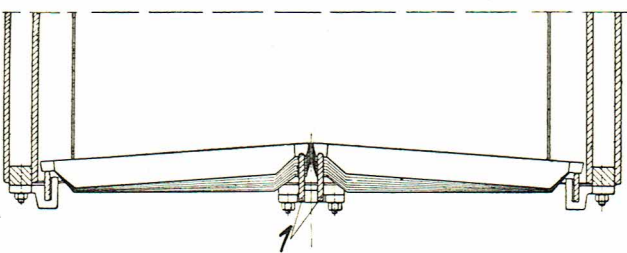
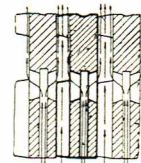
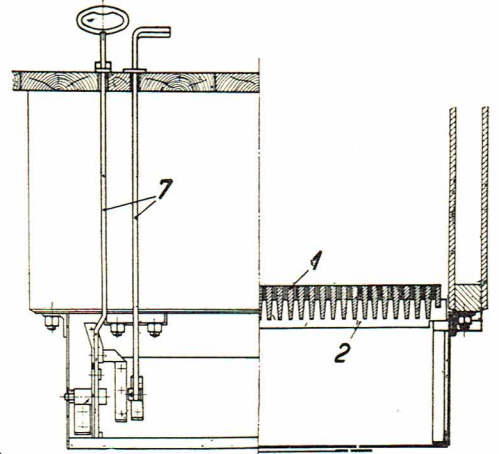

Fig. 80 1:24

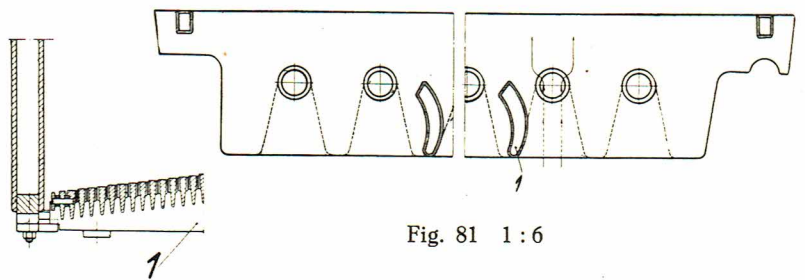

Fig. 81 1:6

Fig. 79-81



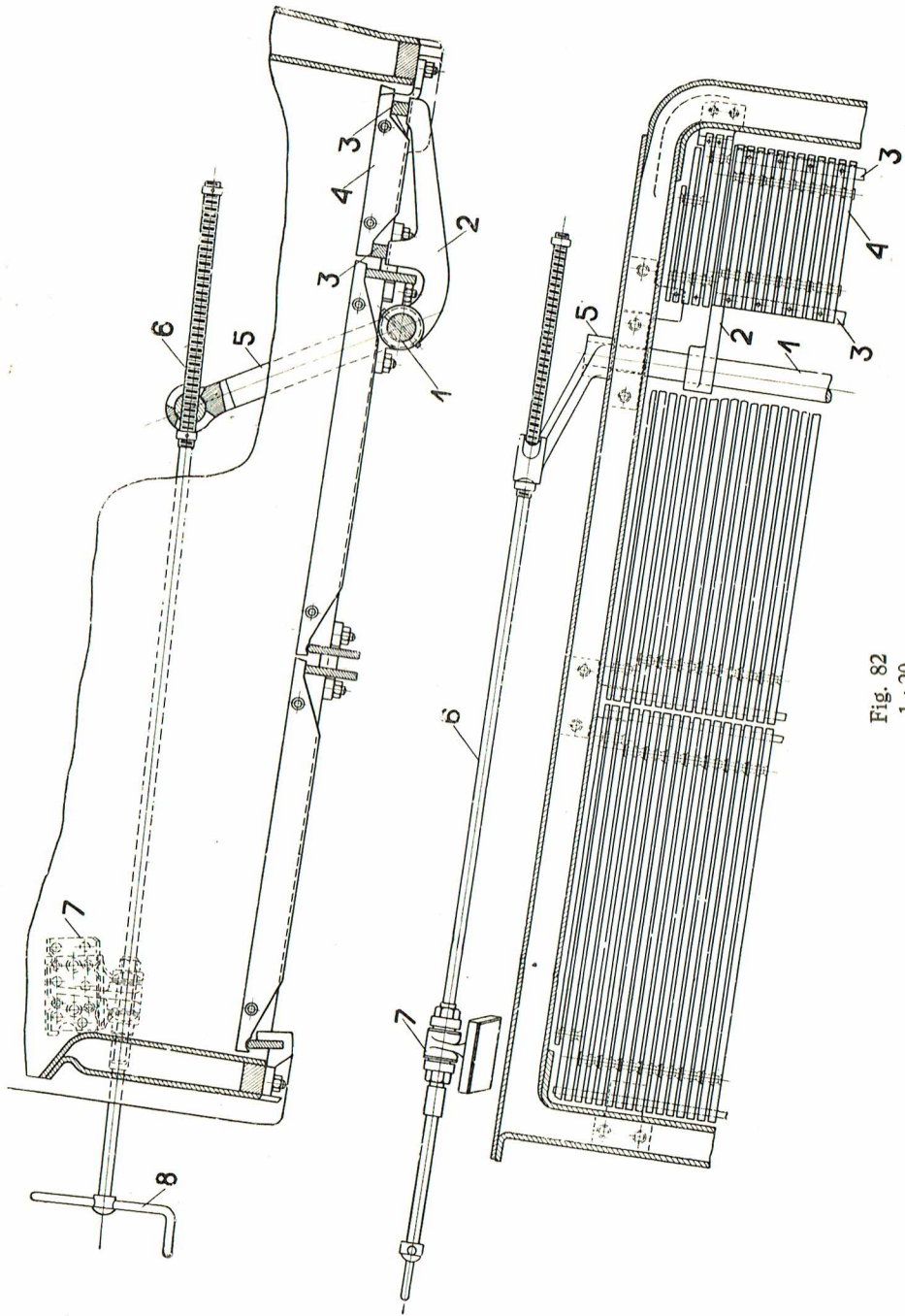

Fig. 82  
1 : 20

Fig. 82

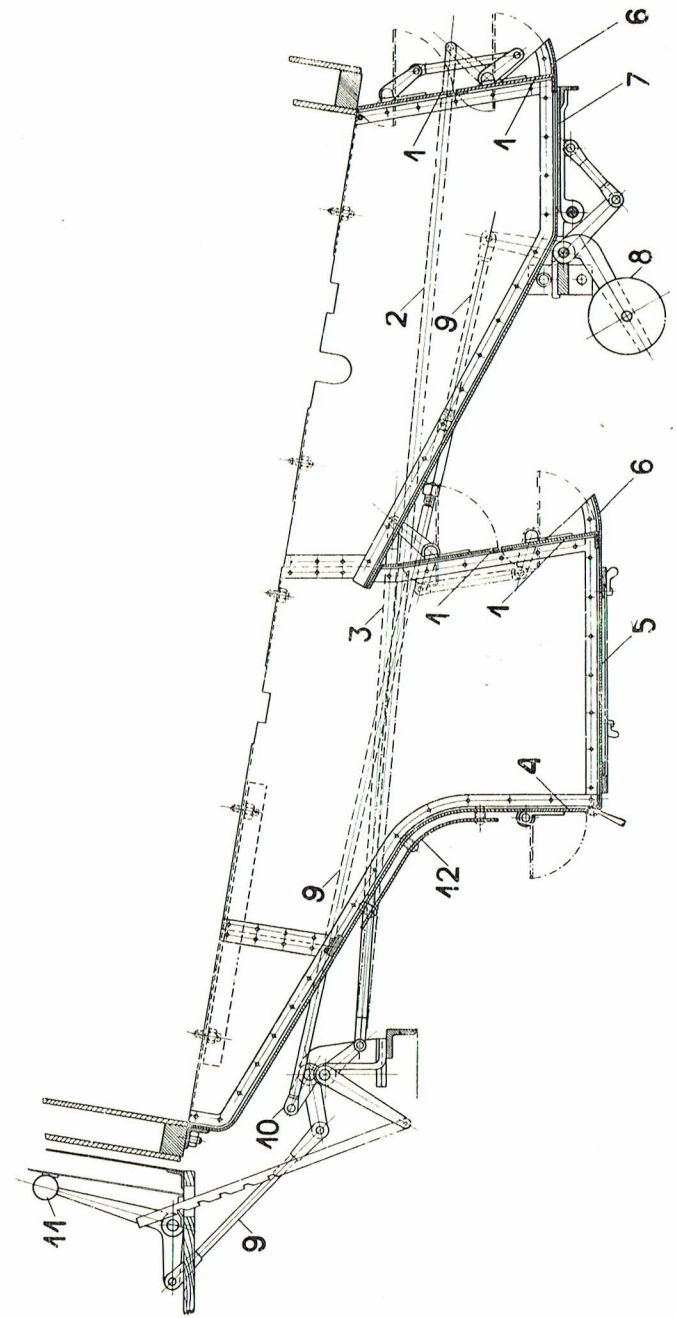

Fig. 83  
1 : 20

Fig. 83

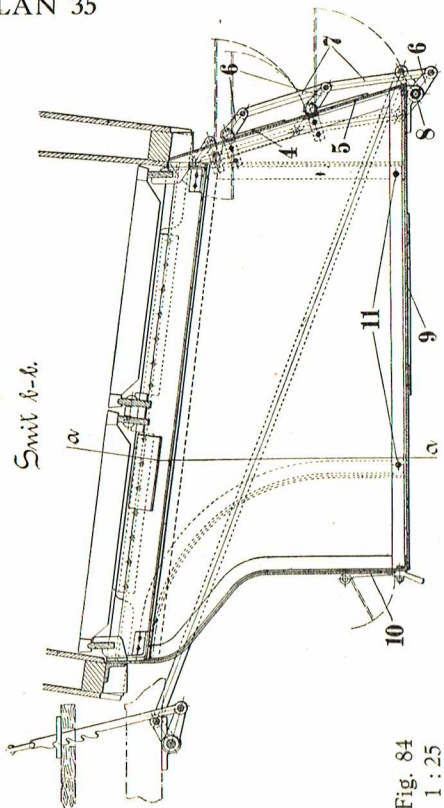

Fig. 84  
1 : 25

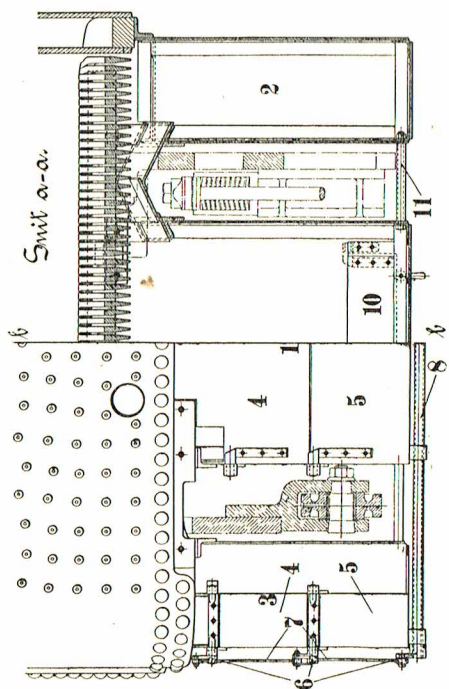

Fig. 84—86

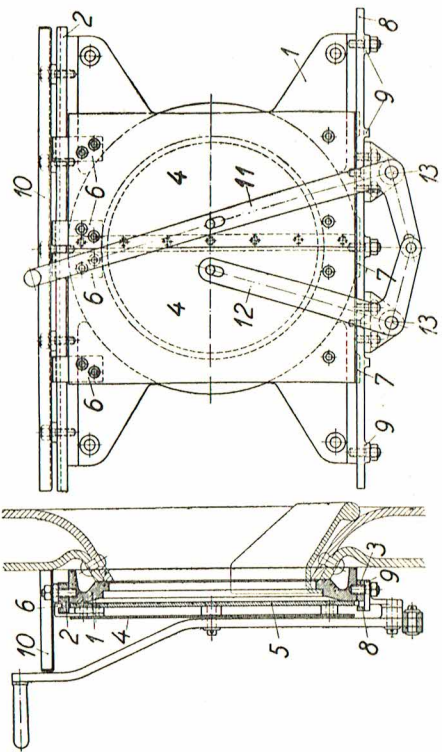

Fig. 86  
1 : 15

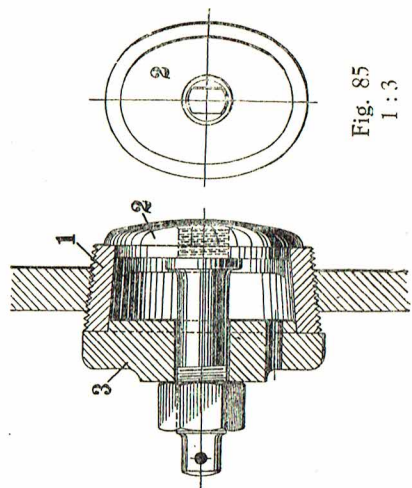

Fig. 85  
1 : 3

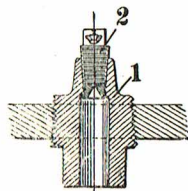
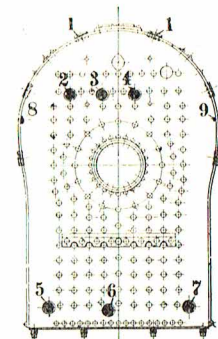

Fig. 88  
1 : 3

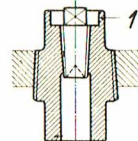

Fig. 89  
1 : 3

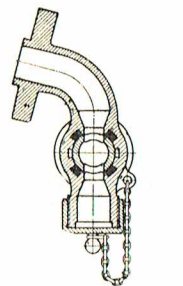

Fig. 91  
1 : 7,5

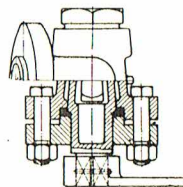

Fig. 92 1 : 4

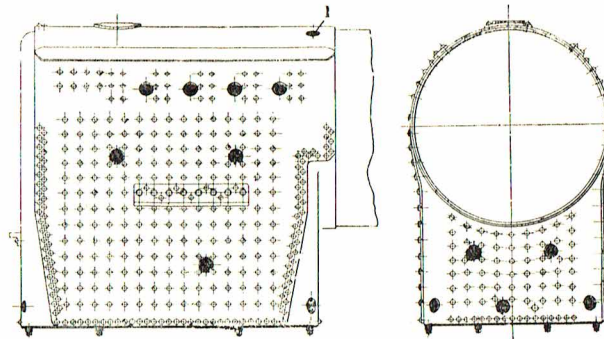

Fig. 87  
1 : 50

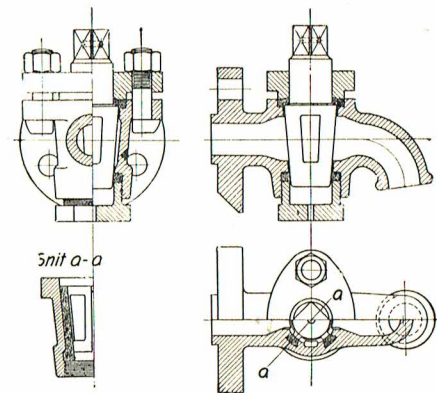
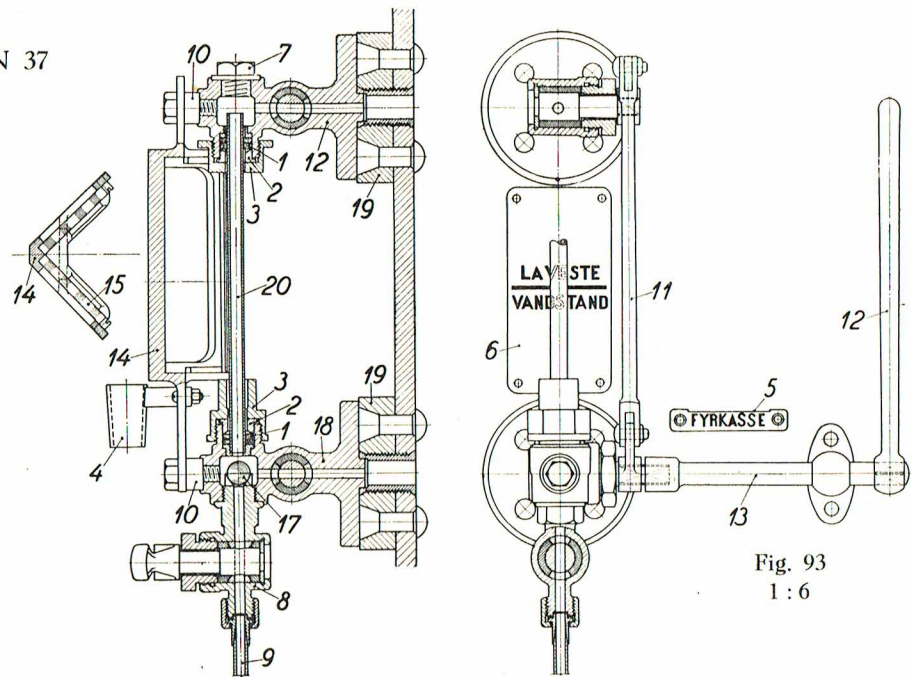

Fig. 90  
1 : 6





Snit a-a.

Snit b-b.

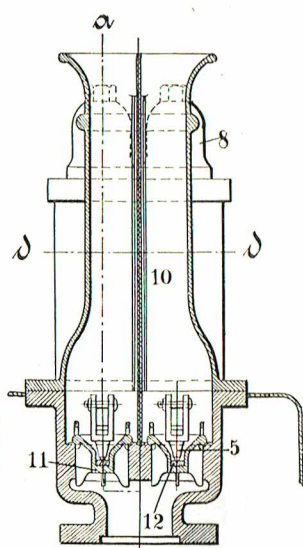
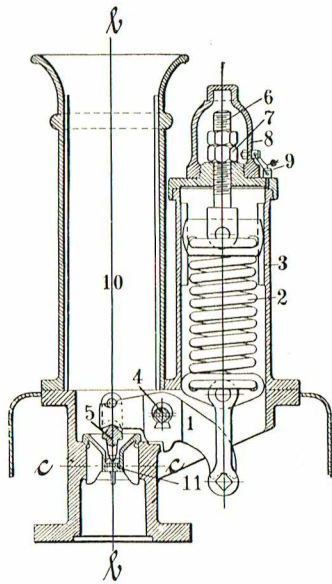
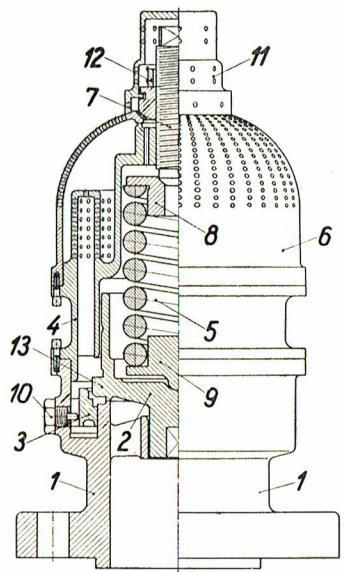

Snit d-d.

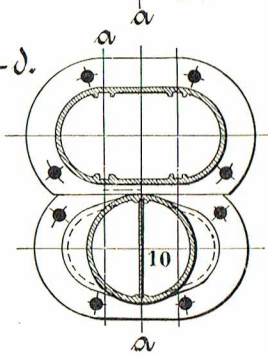

Snit c-c.

Fig. 94  
1:10

Fig. 93—95

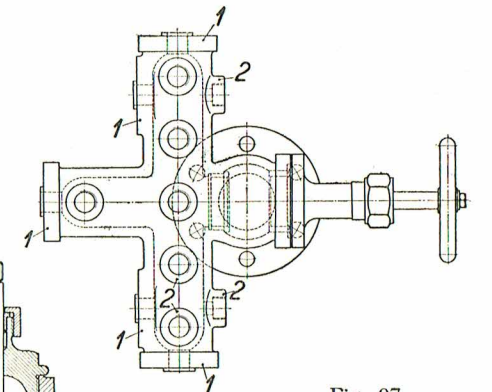
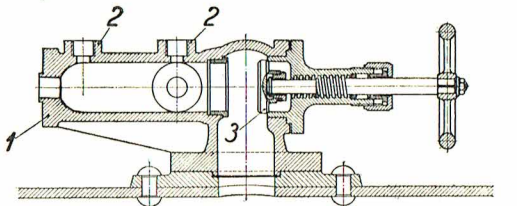
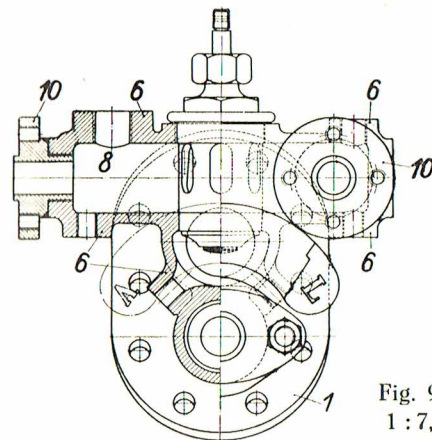
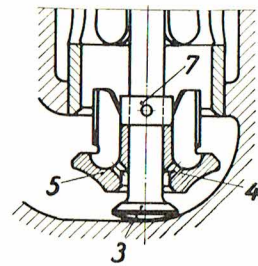
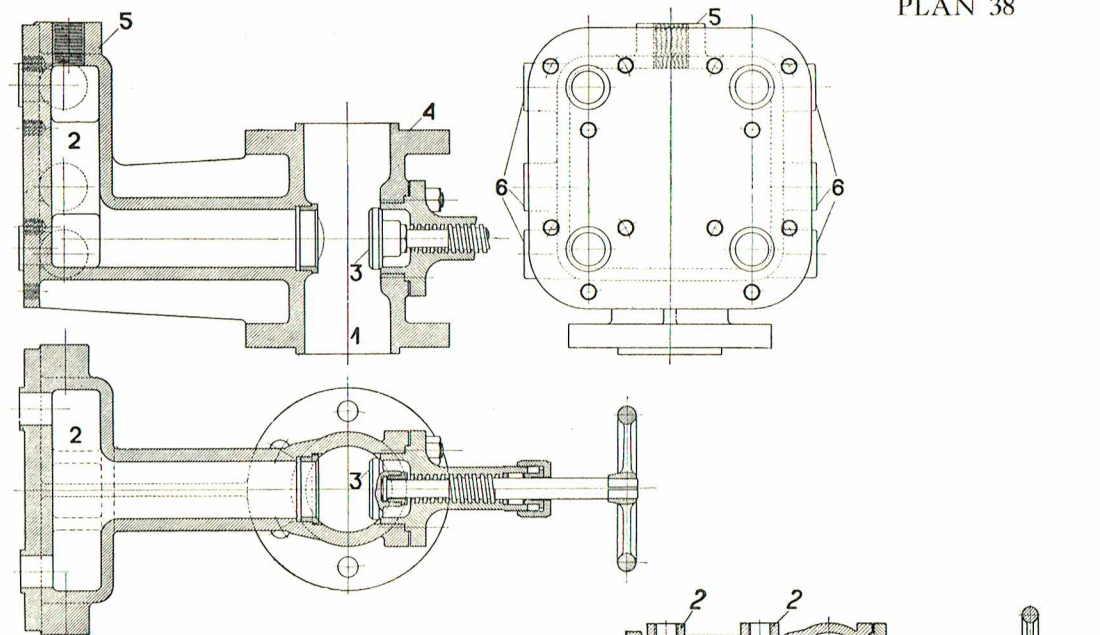

Fig. 96—98



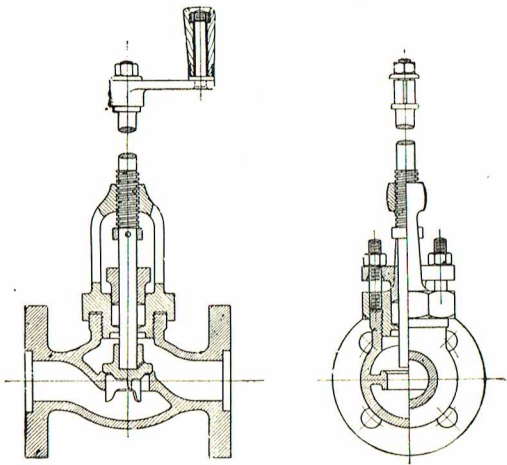

Fig. 100  
1:6

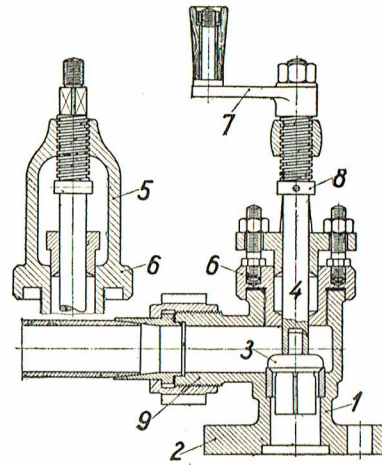

Fig. 99  
1:5

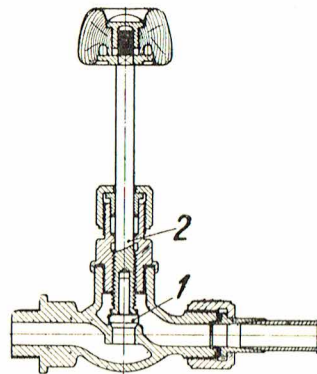

Fig. 101 1:4

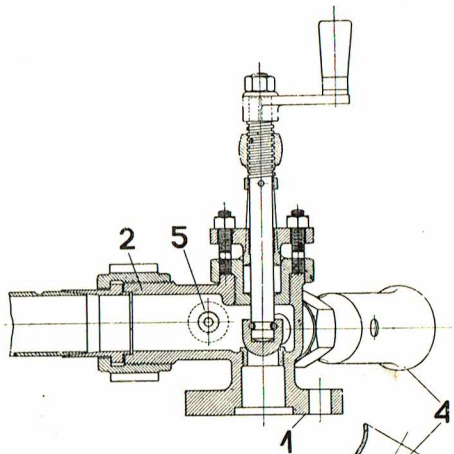

Fig. 102  
1:6

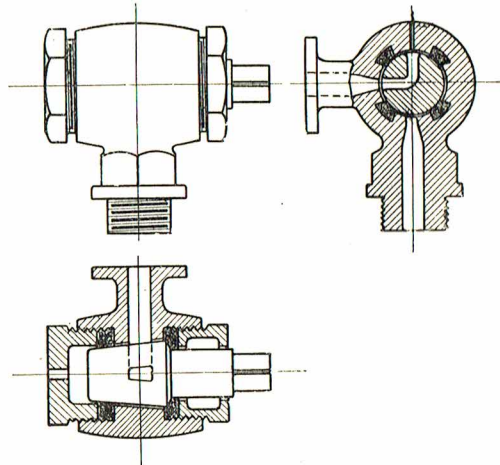

Fig. 103  
1:3

Fig. 99—103

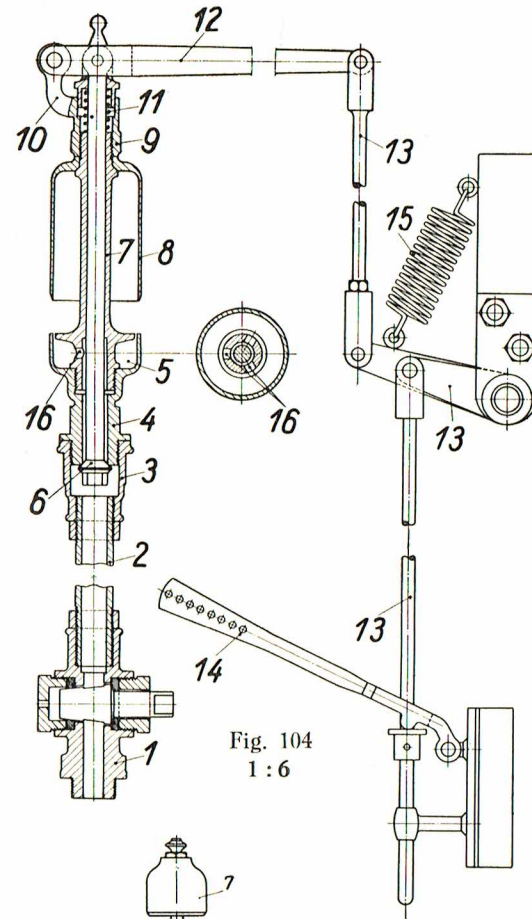

Fig. 104  
1:6

Fig. 105  
1:6

Fig. 108 a

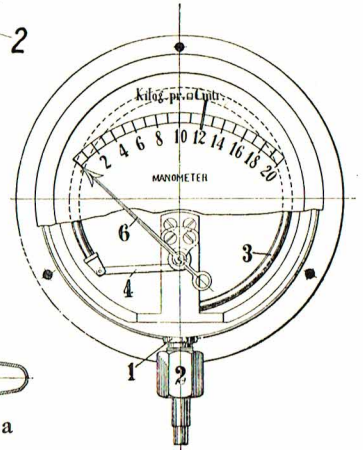

Fig. 108  
1:4

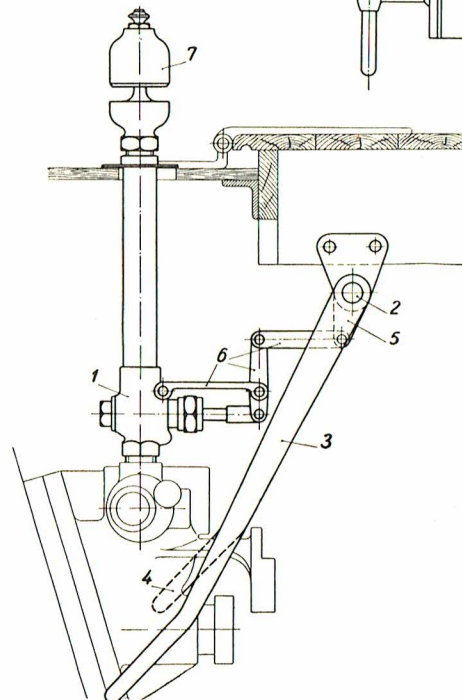

Fig. 106  
1:10

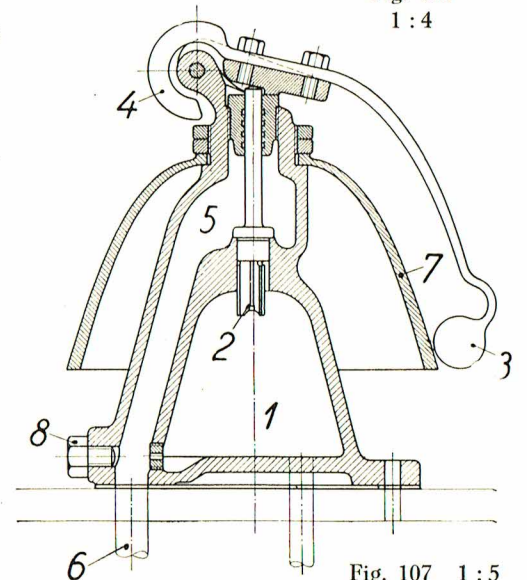

Fig. 107 1:5

Fig. 104—108



Fig. 109 b

Fig. 109 a

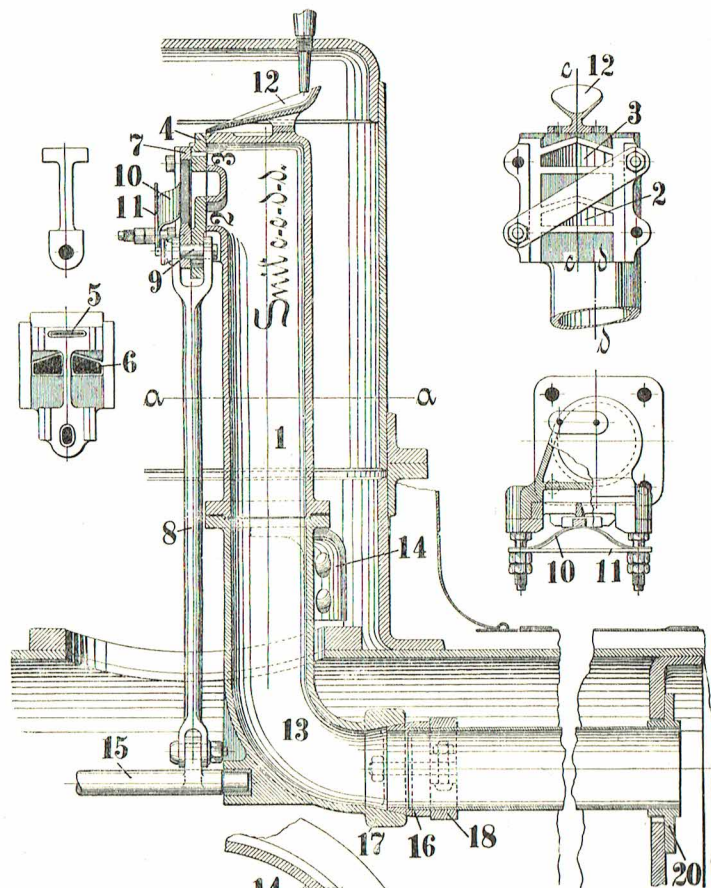

Fig. 109  
1:12

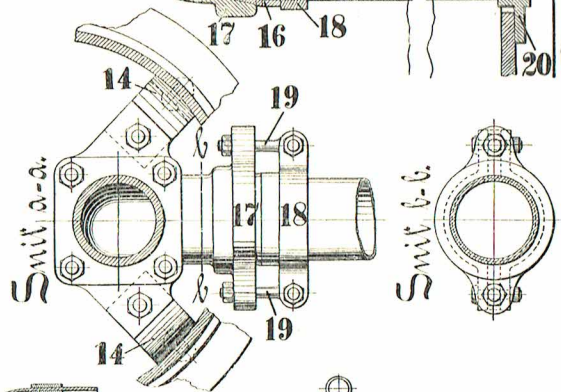

Fig. 110  
1:12

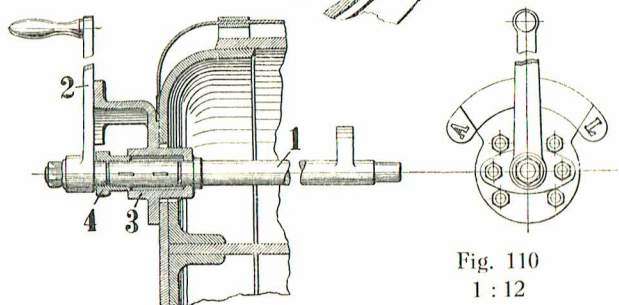

Fig. 109—110

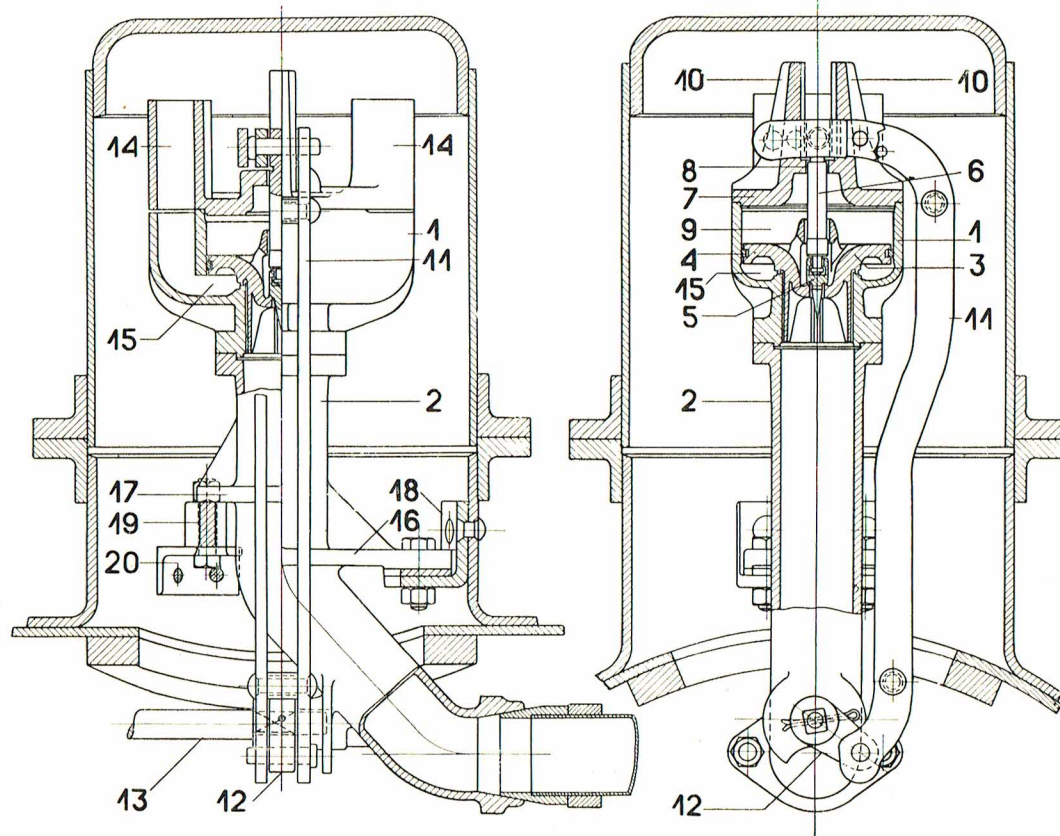

Fig. 111  
1:10

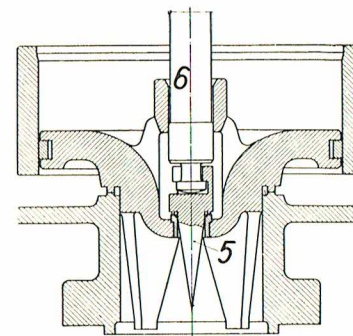

Fig. 111 a 1:5

Fig. 111—111 a

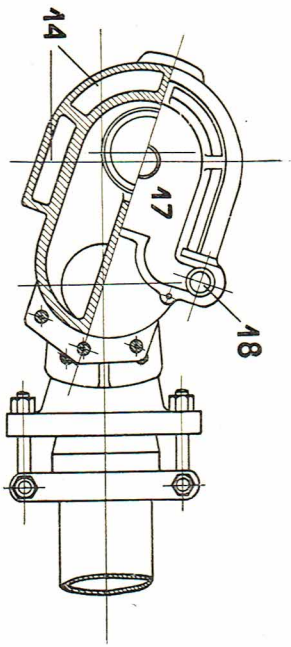
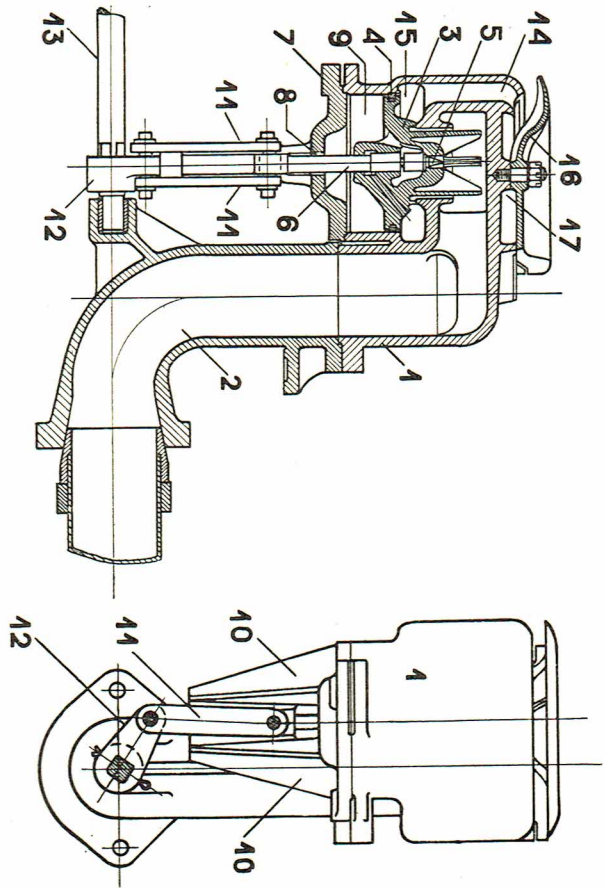

Fig. 112  
1 : 12,5

Fig. 112

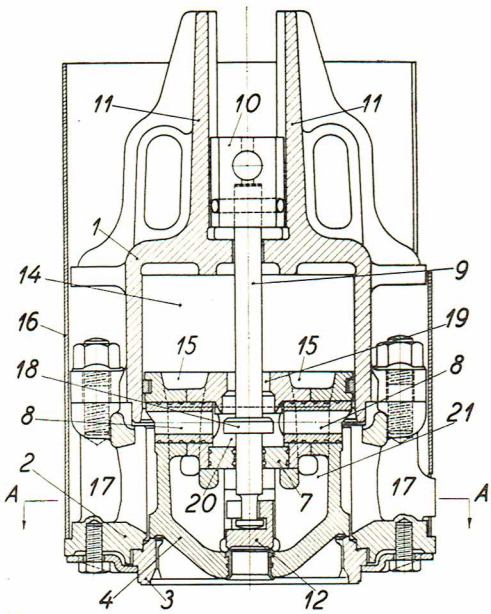

Fig. 113  
1 : 6

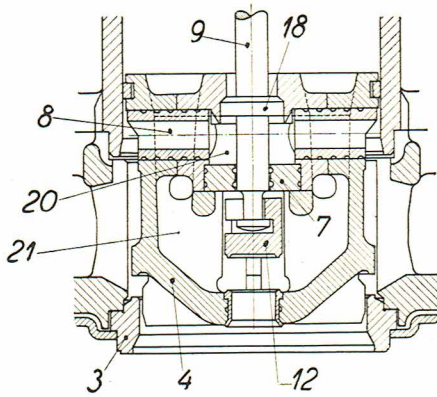

Fig. 113 a  
1 : 5

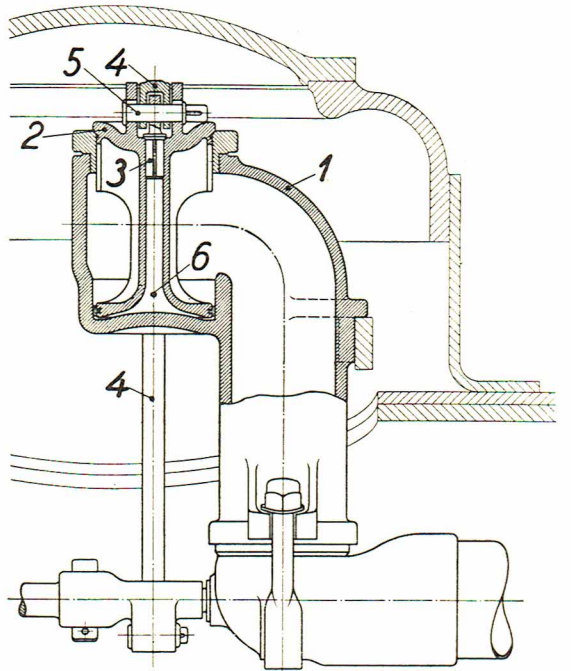
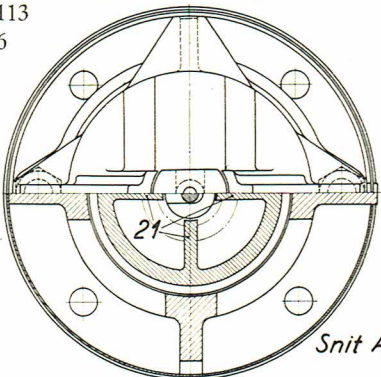

Fig. 114  
1 : 10



Snit A-A

Fig. 113—114



Fig. 115-116

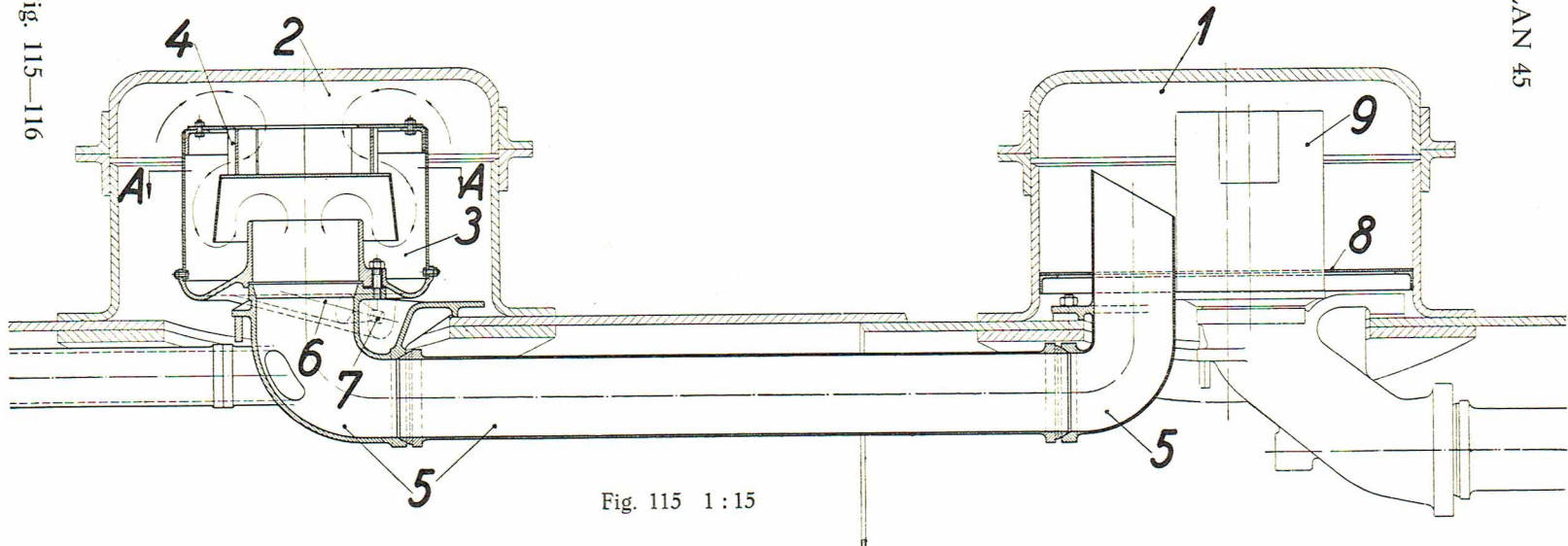

Fig. 115 1:15

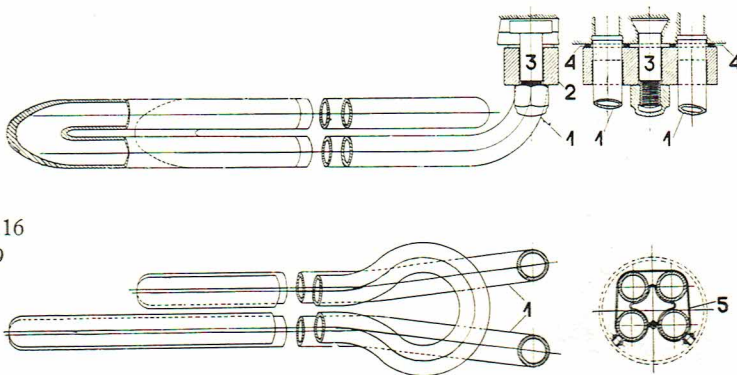
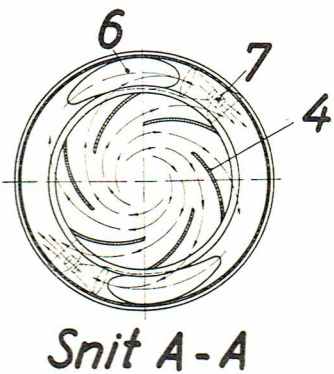

Fig. 116 1:9

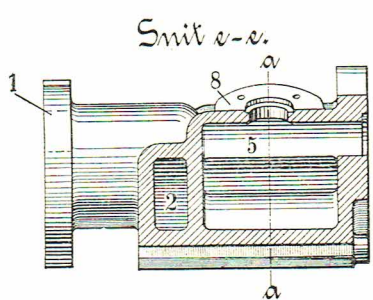
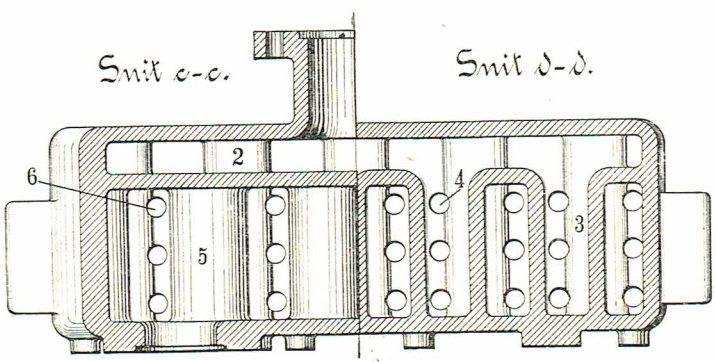
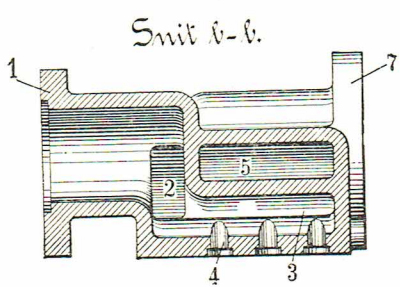
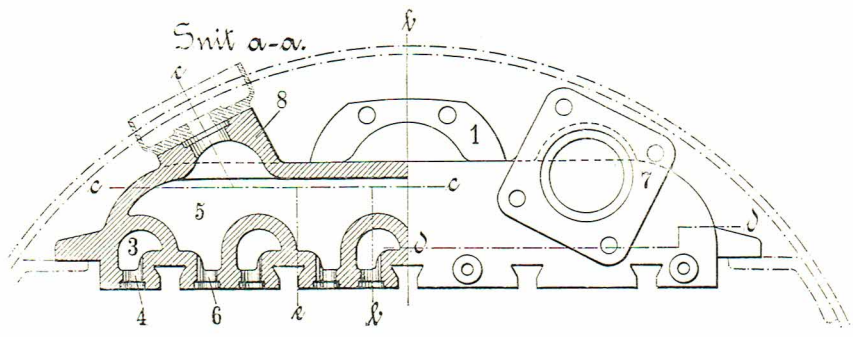

Fig. 117 1:10

Fig. 117

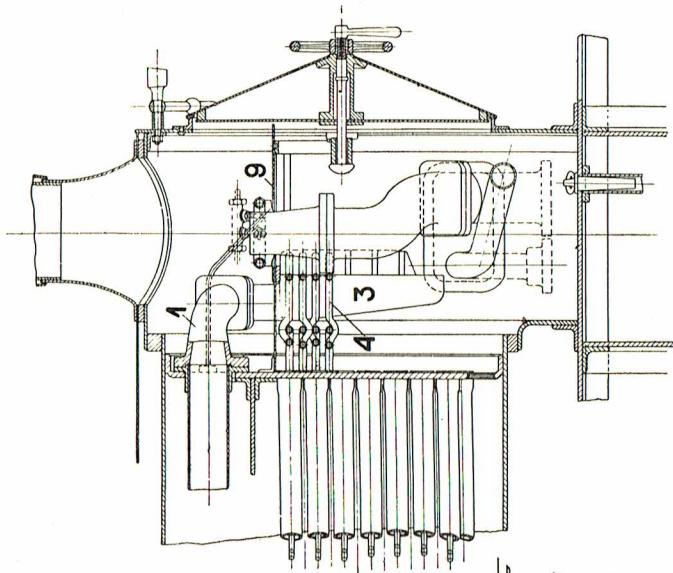

Fig. 118  
1:25

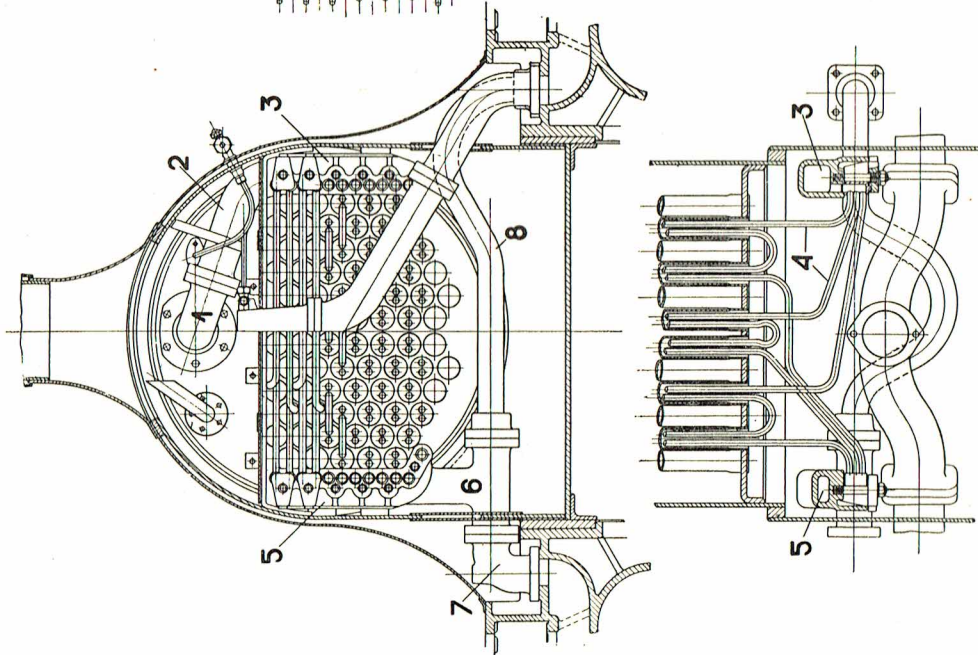

Fig. 118

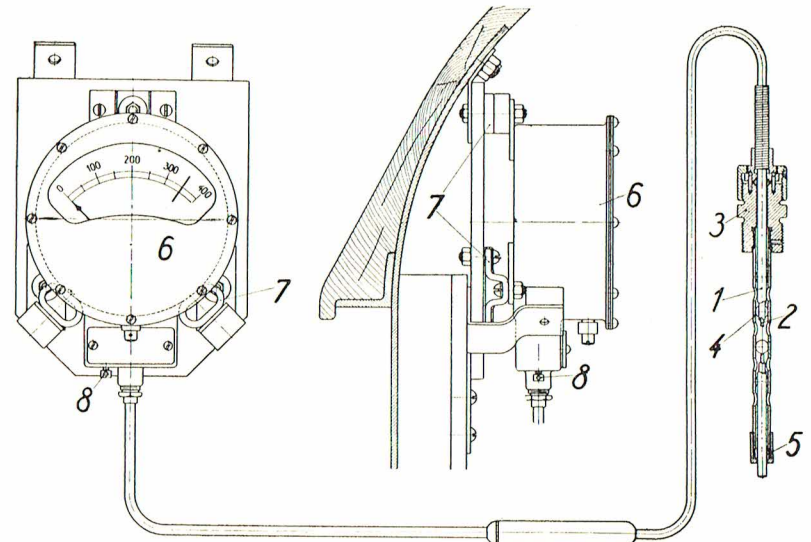

Fig. 121  
1:6

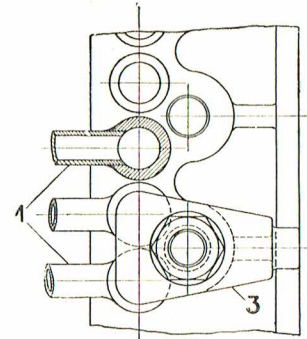

Fig. 119  
1:5

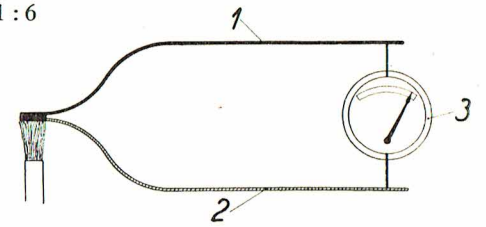

Fig. 120

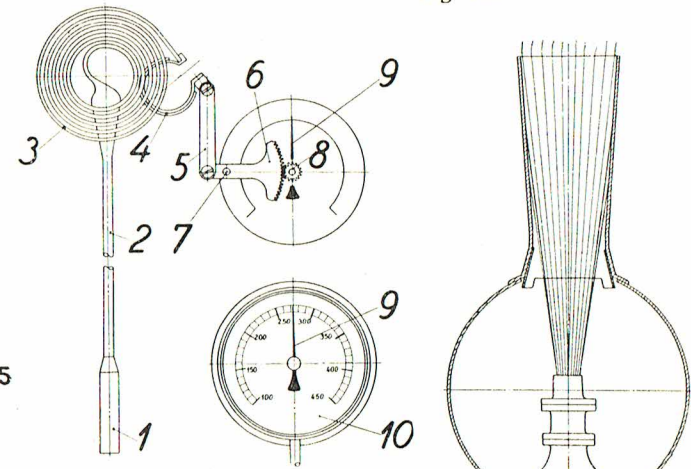
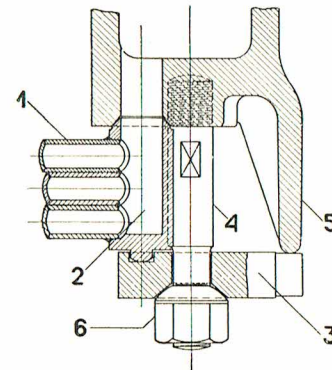

Fig. 122

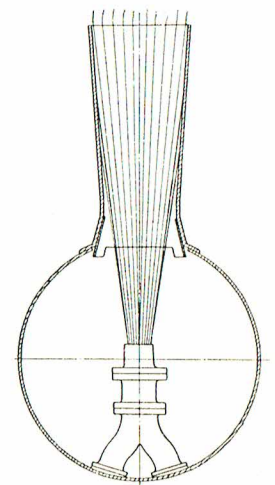

Fig. 123



PLAN 49

Fig. 124—126 a

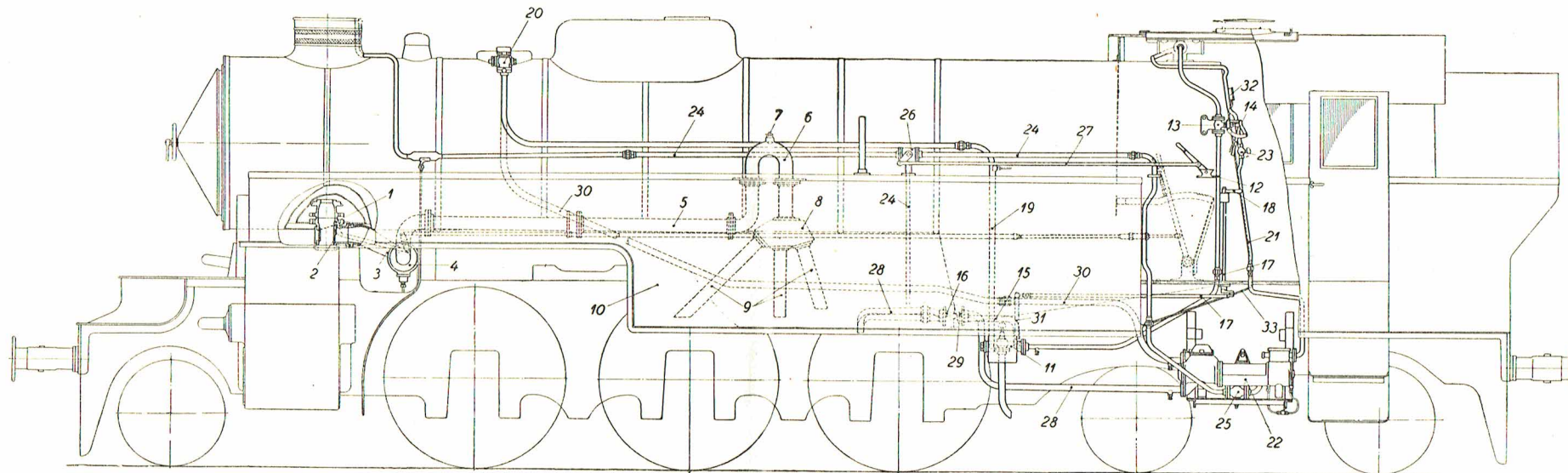

Fig. 124 1:60

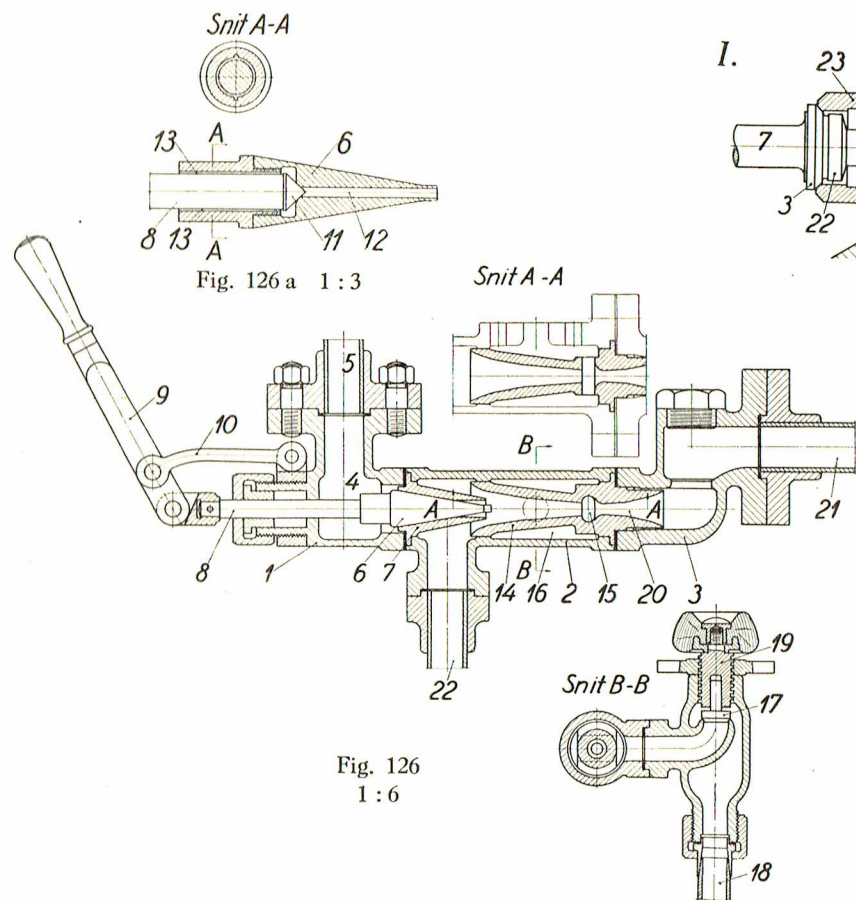

Fig. 126 a 1:3

Fig. 126  
1:6

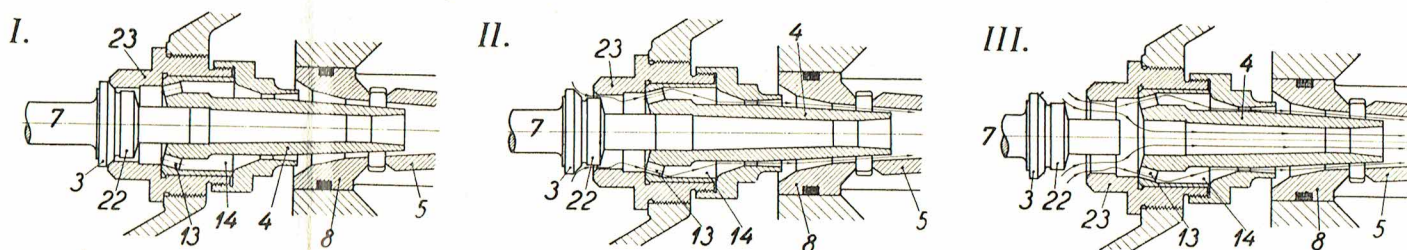

Fig. 125 a 1:3

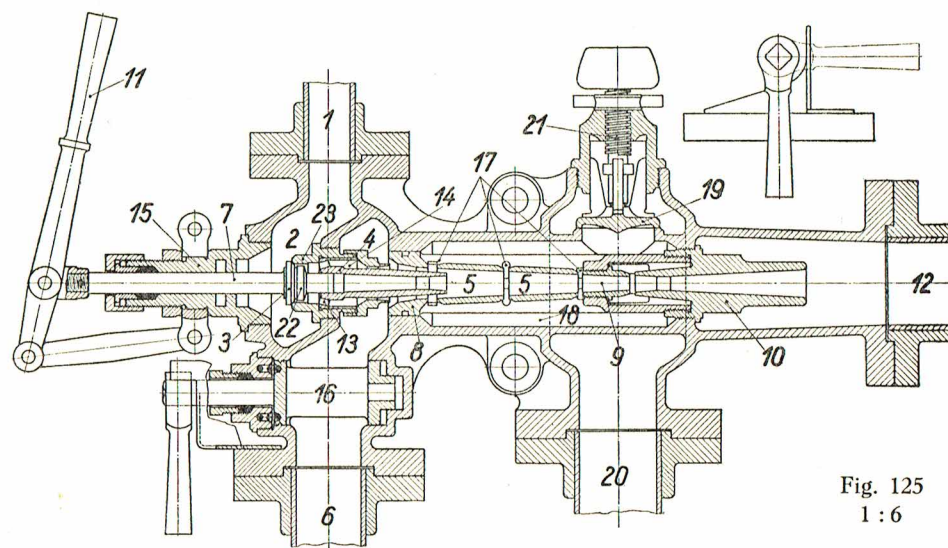

Fig. 125  
1:6



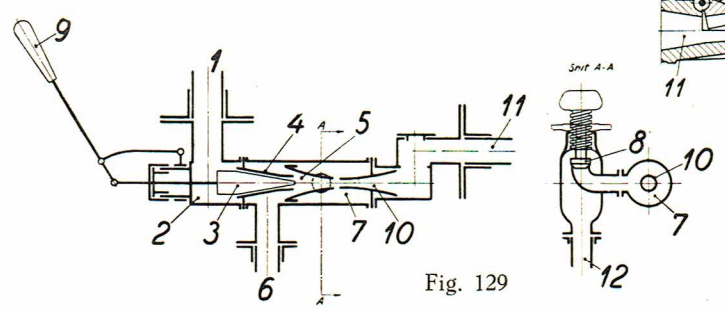
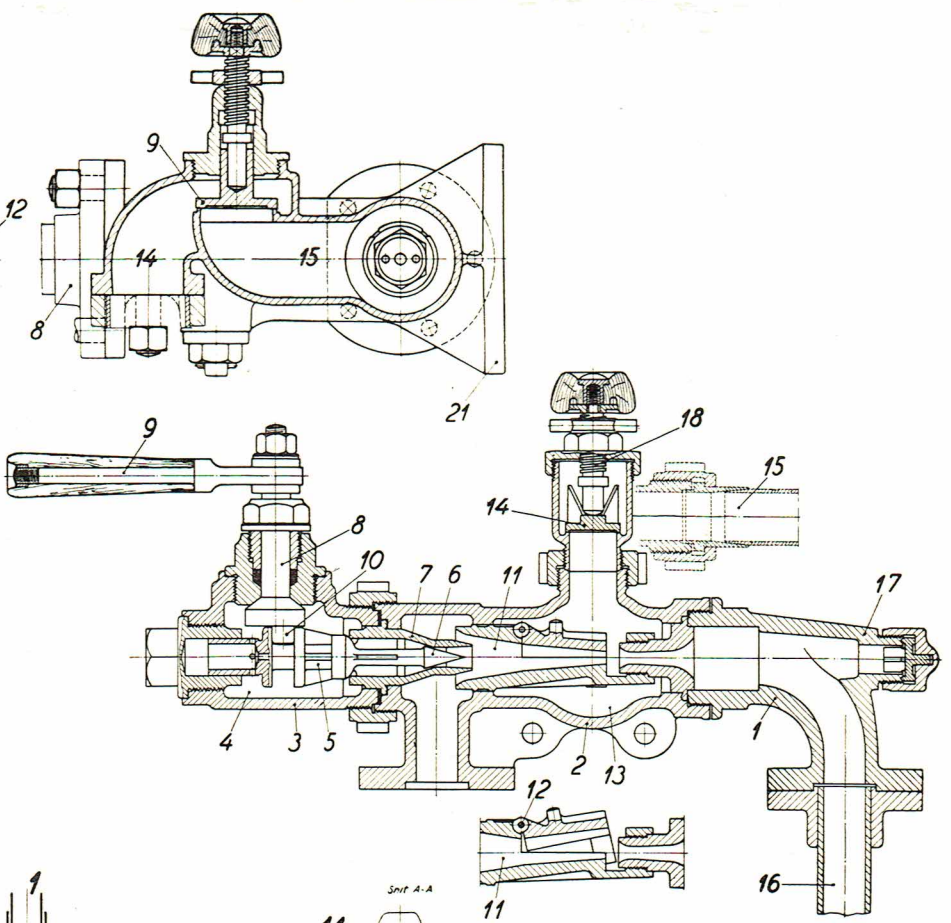
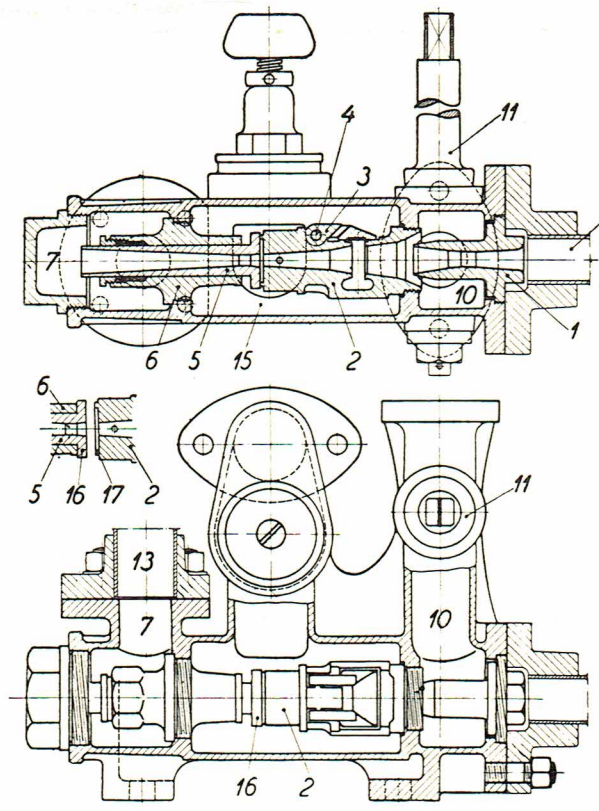

Fig. 127-129

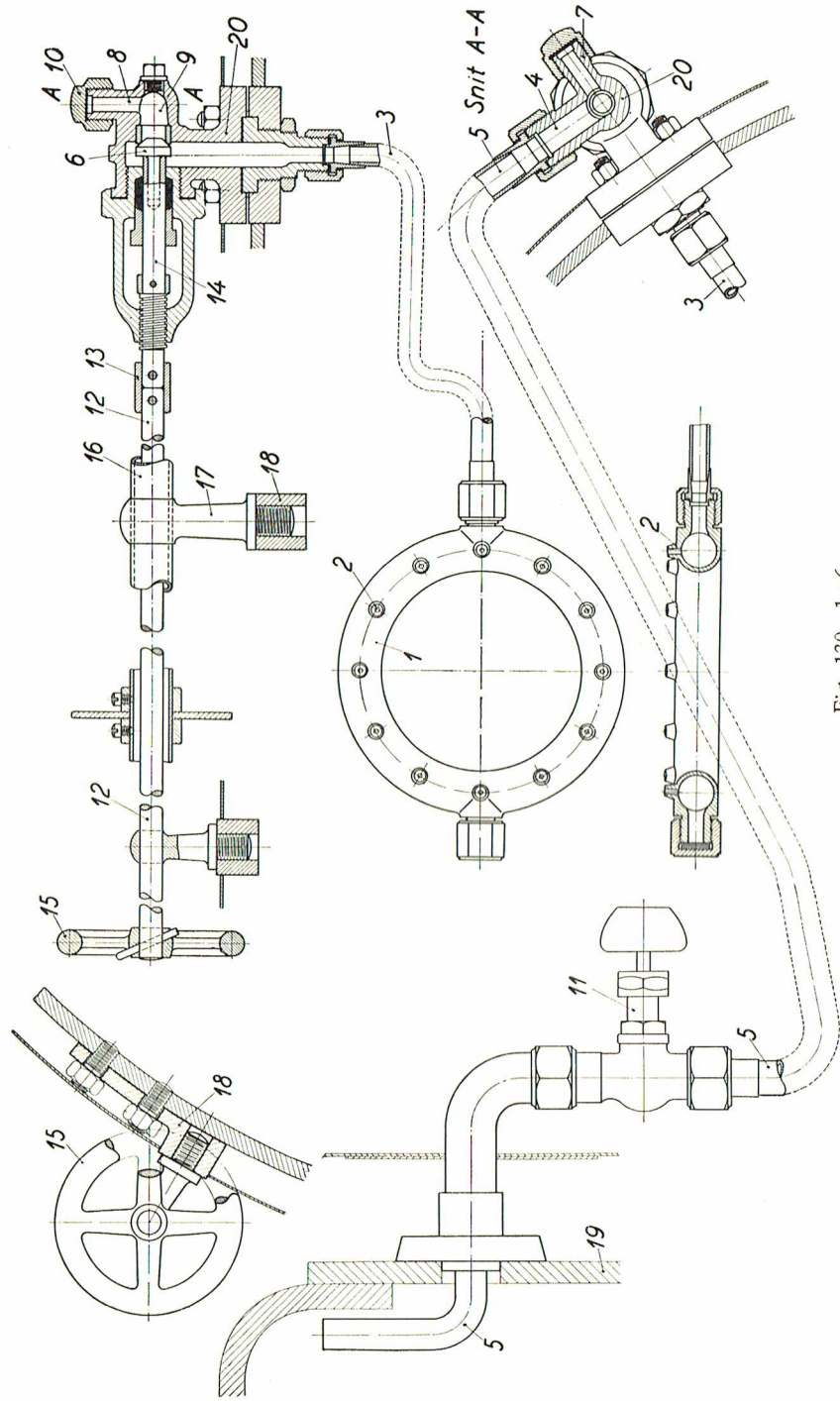

Fig. 130 1:6

Fig. 130

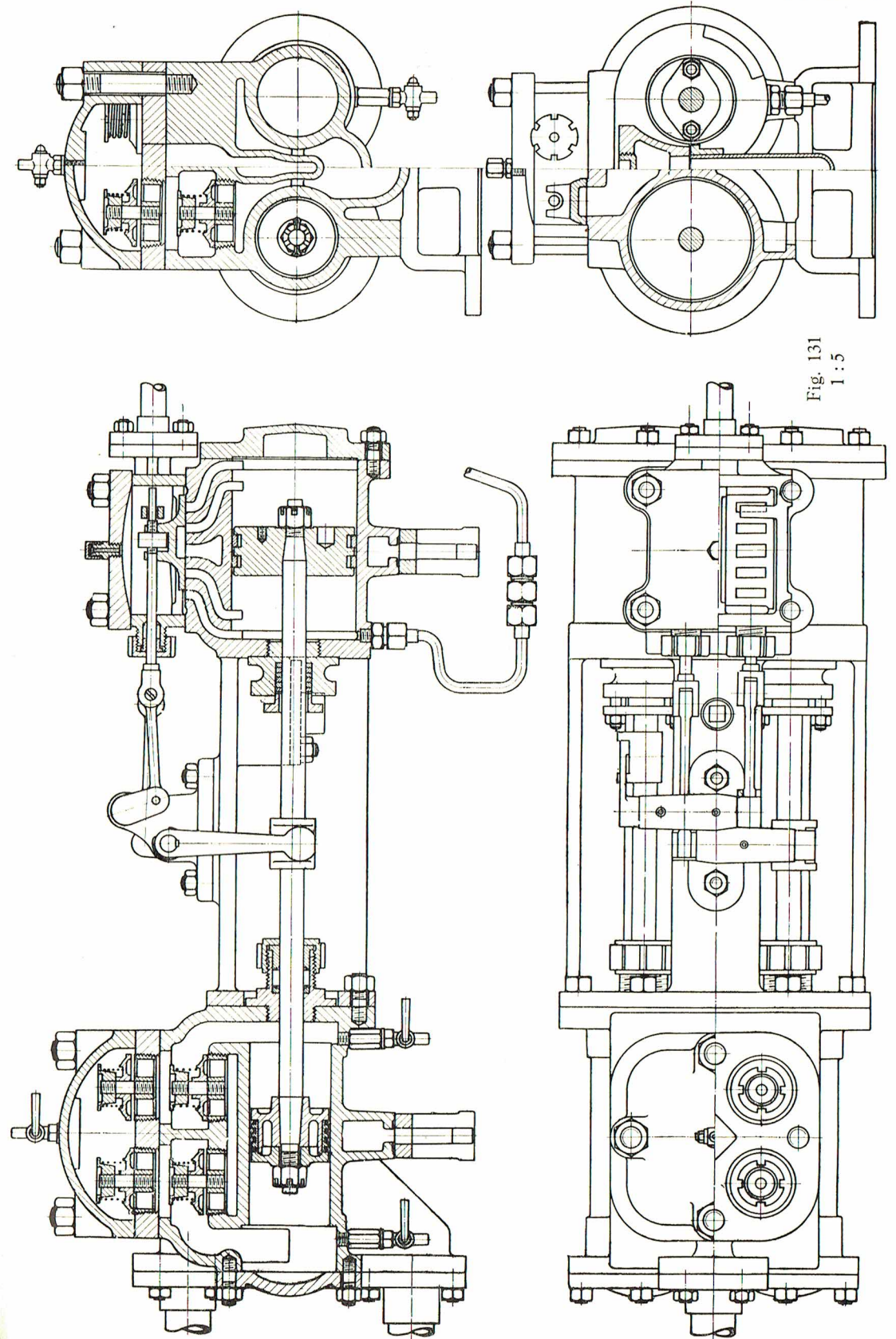
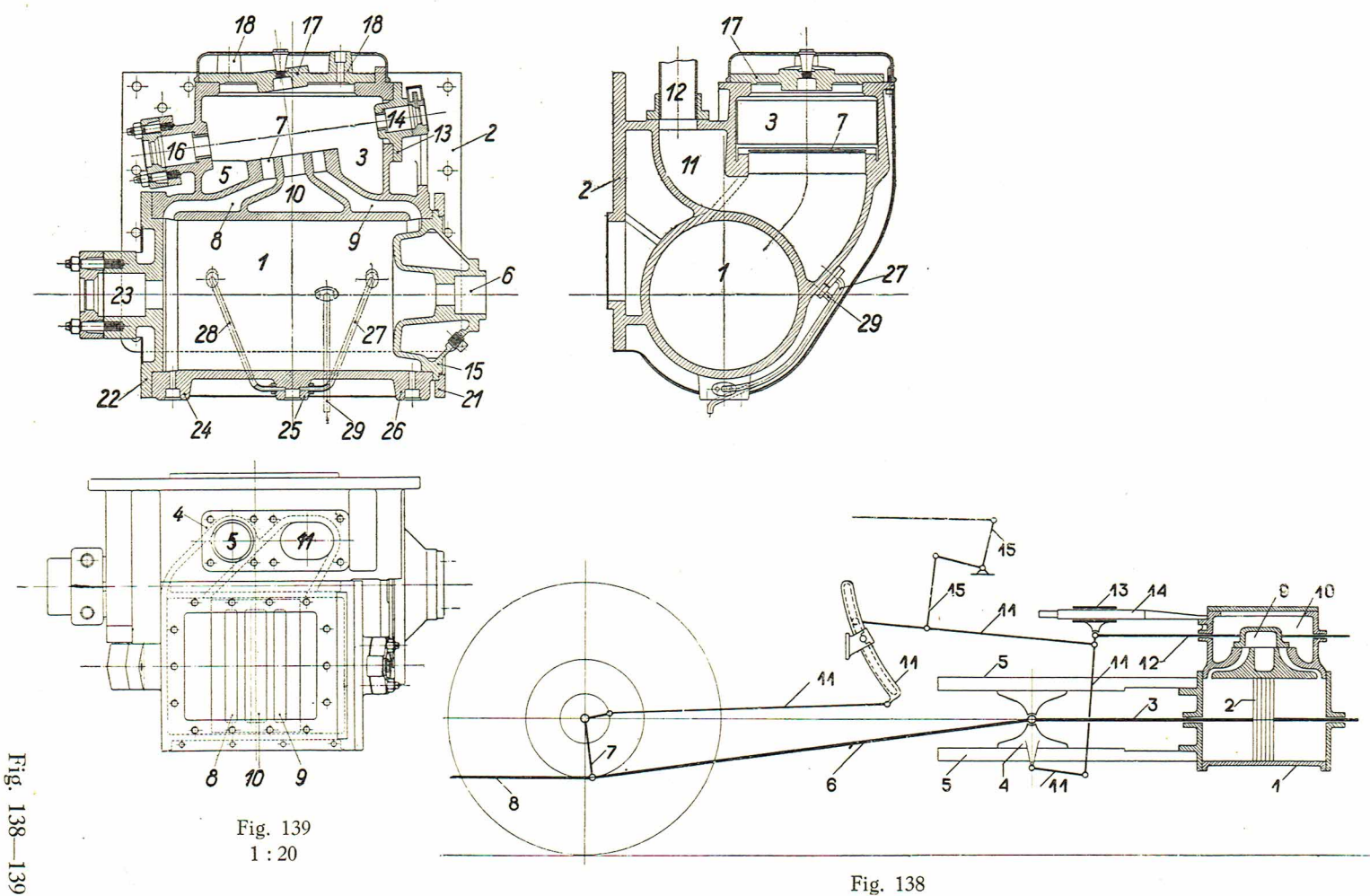
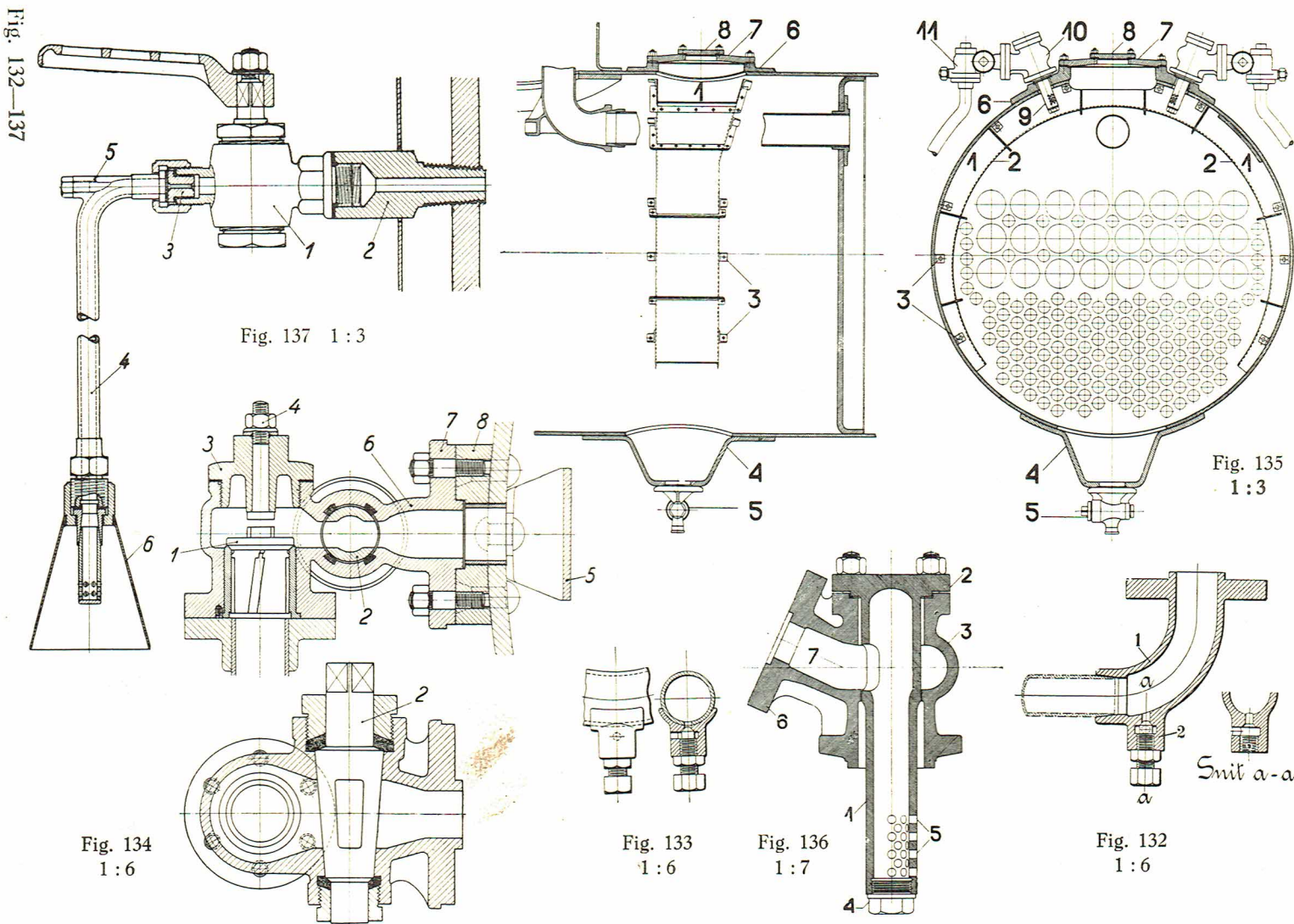

Fig. 131  
1:5







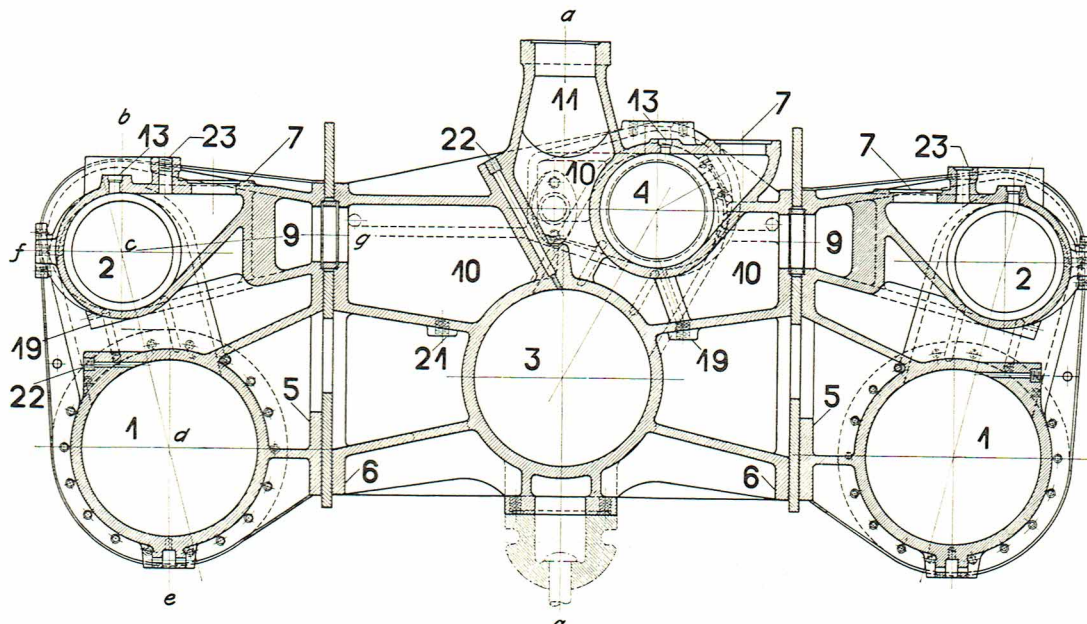

Fig. 140 a  
1 : 20

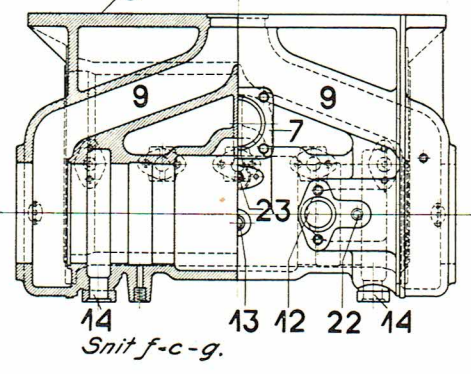
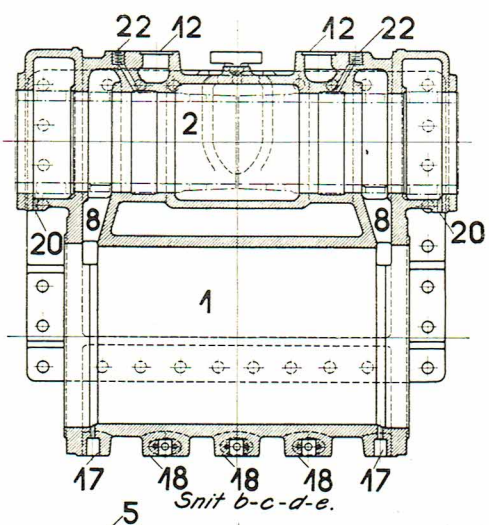

Fig. 140 b  
1 : 20

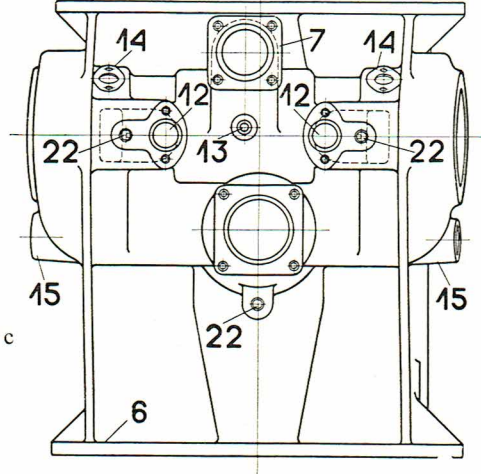
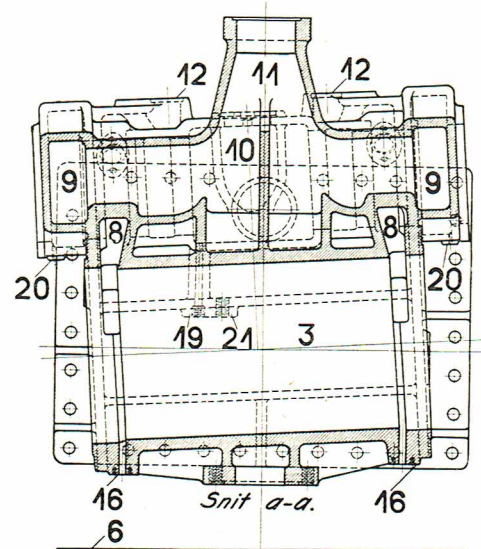

Fig. 140 c  
1 : 20



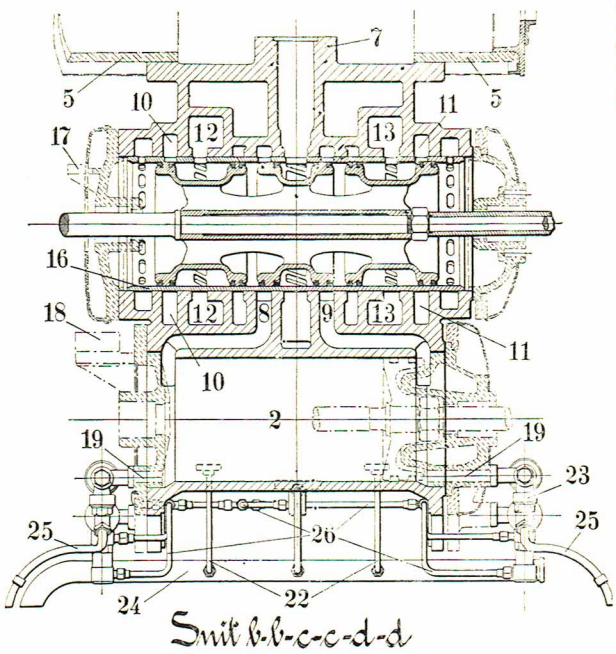

Fig. 141  
1 : 20

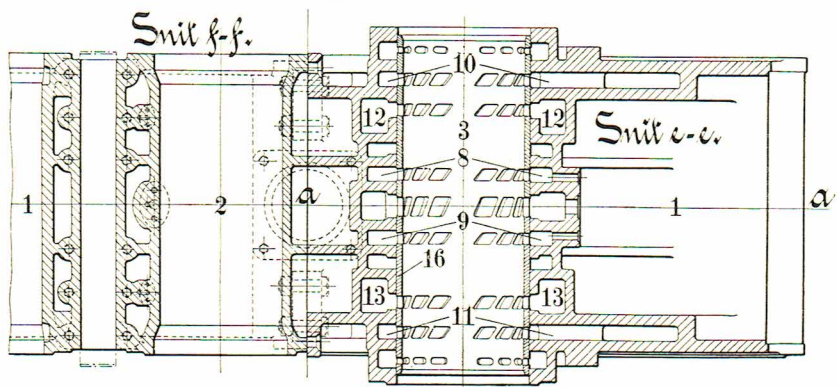
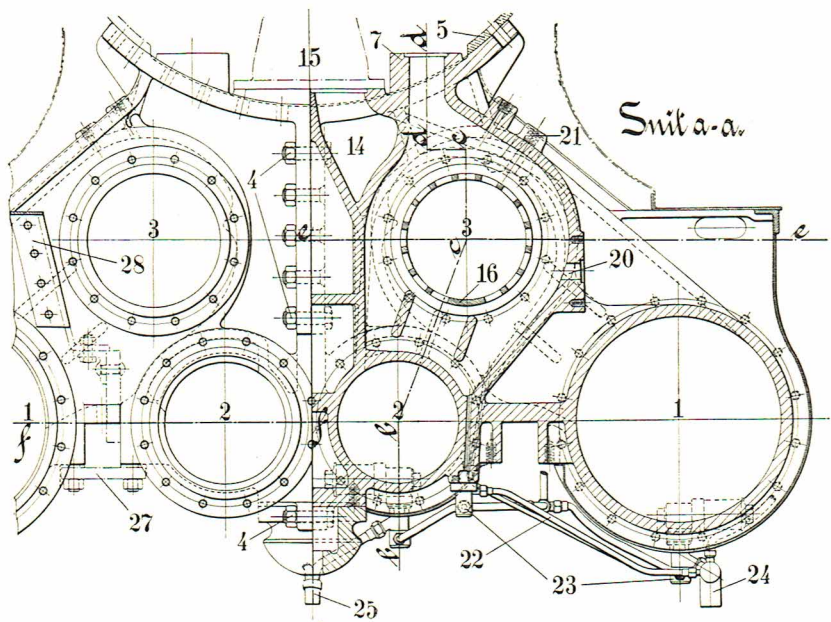

Fig. 141

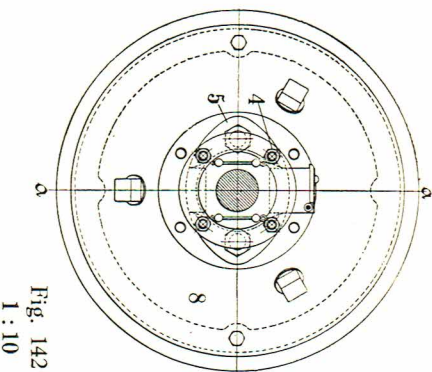

Fig. 142  
1 : 10

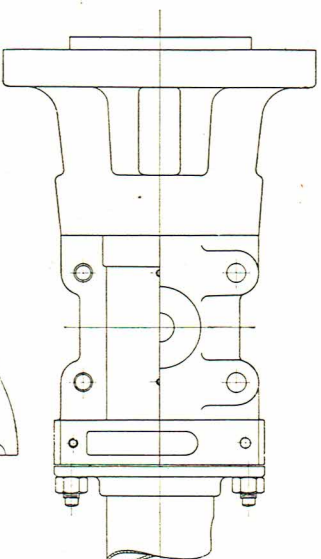
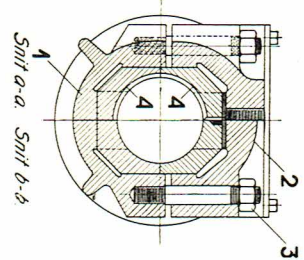
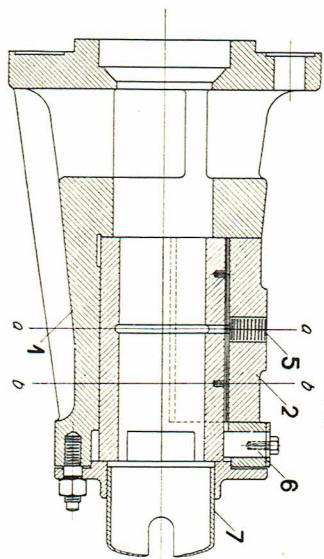
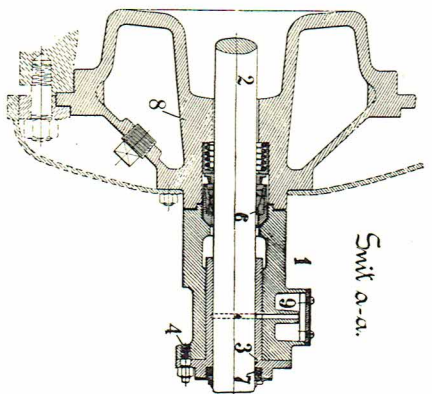

Fig. 143 1 : 6

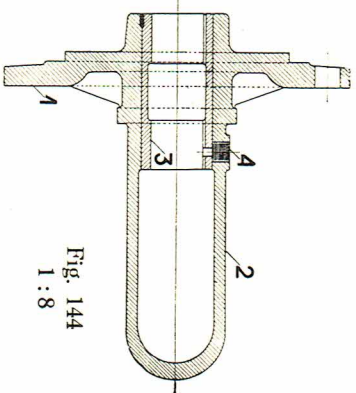
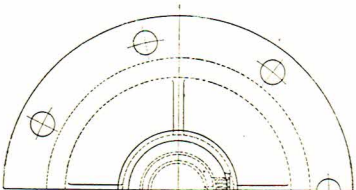

Fig. 144  
1 : 8



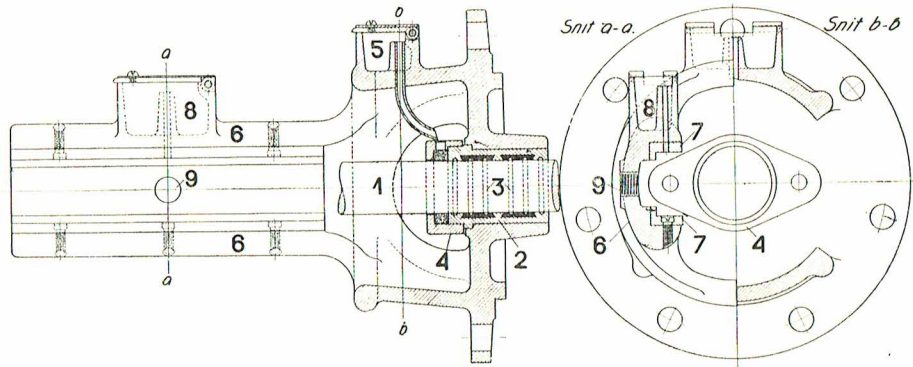

Fig. 145  
1:8

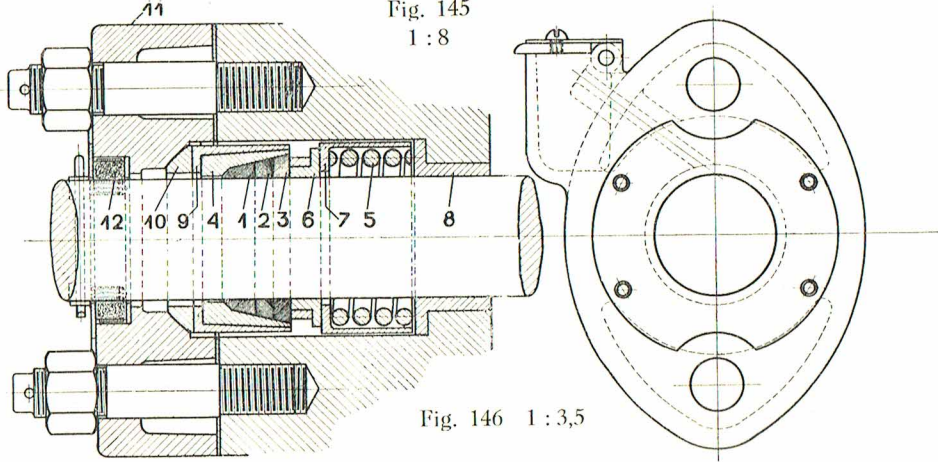

Fig. 146 1:3,5

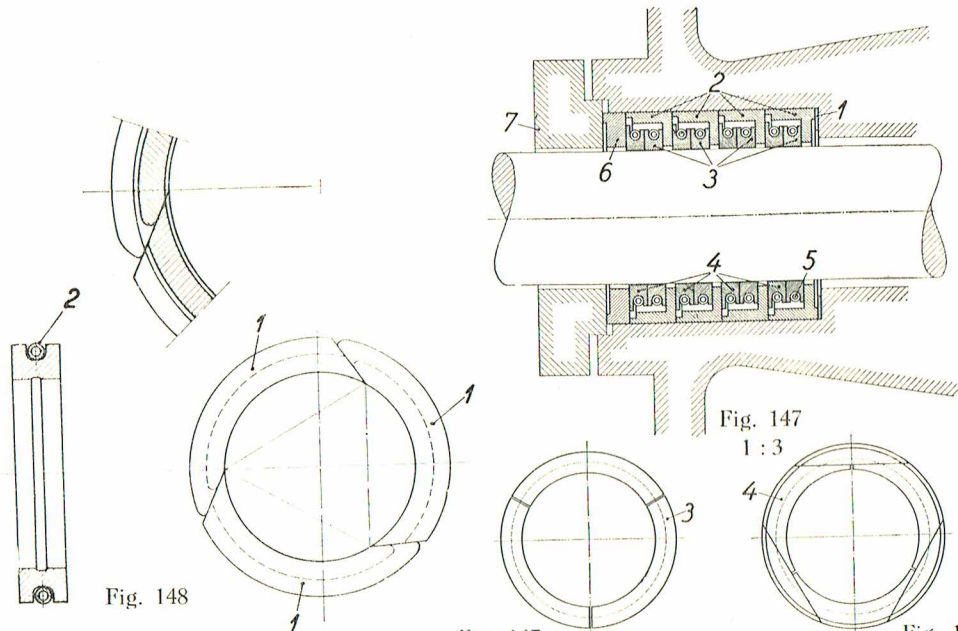

Fig. 147  
1:3

Fig. 147 a

Fig. 147 b

Fig. 145—148

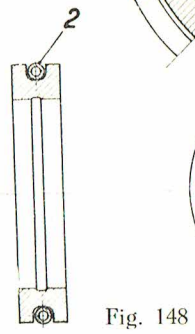

Fig. 148

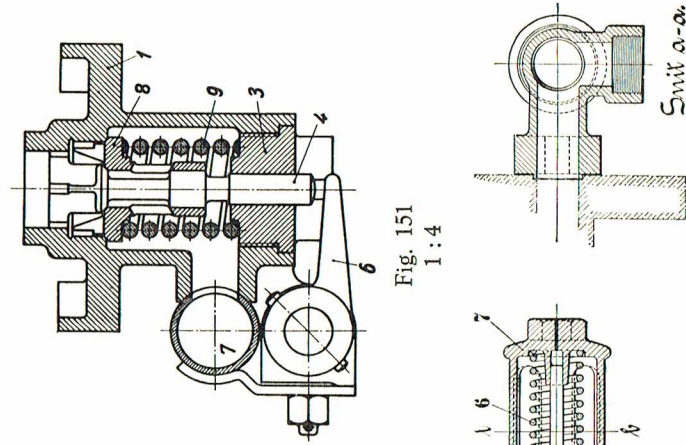

Fig. 149  
1:5

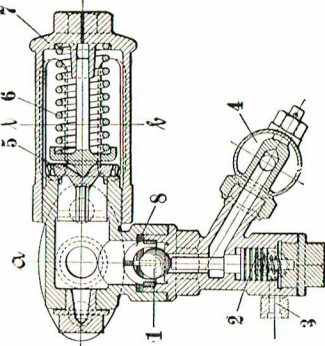
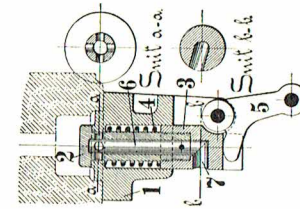

Fig. 151  
1:4

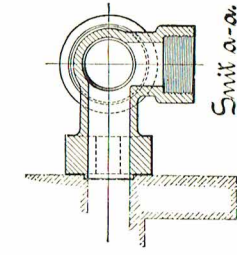

Fig. 152  
1:6

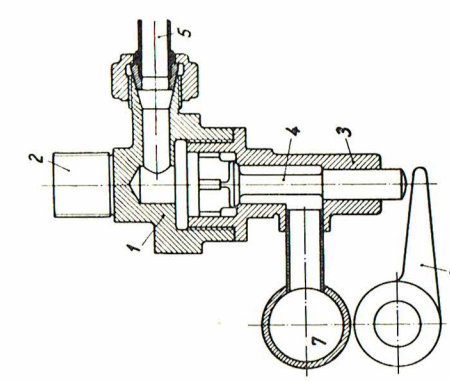

Fig. 153  
1:4

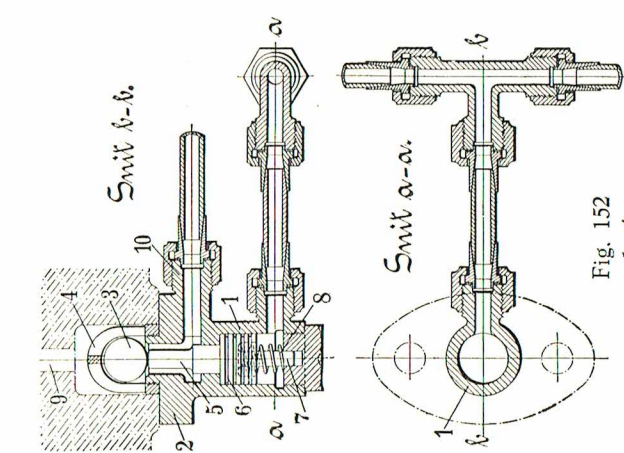

Fig. 154  
1:3

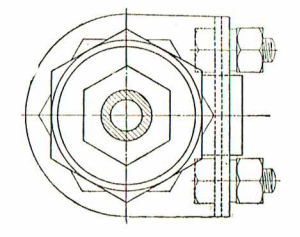

Fig. 155  
1:3

Fig. 149—154



Fig. 155

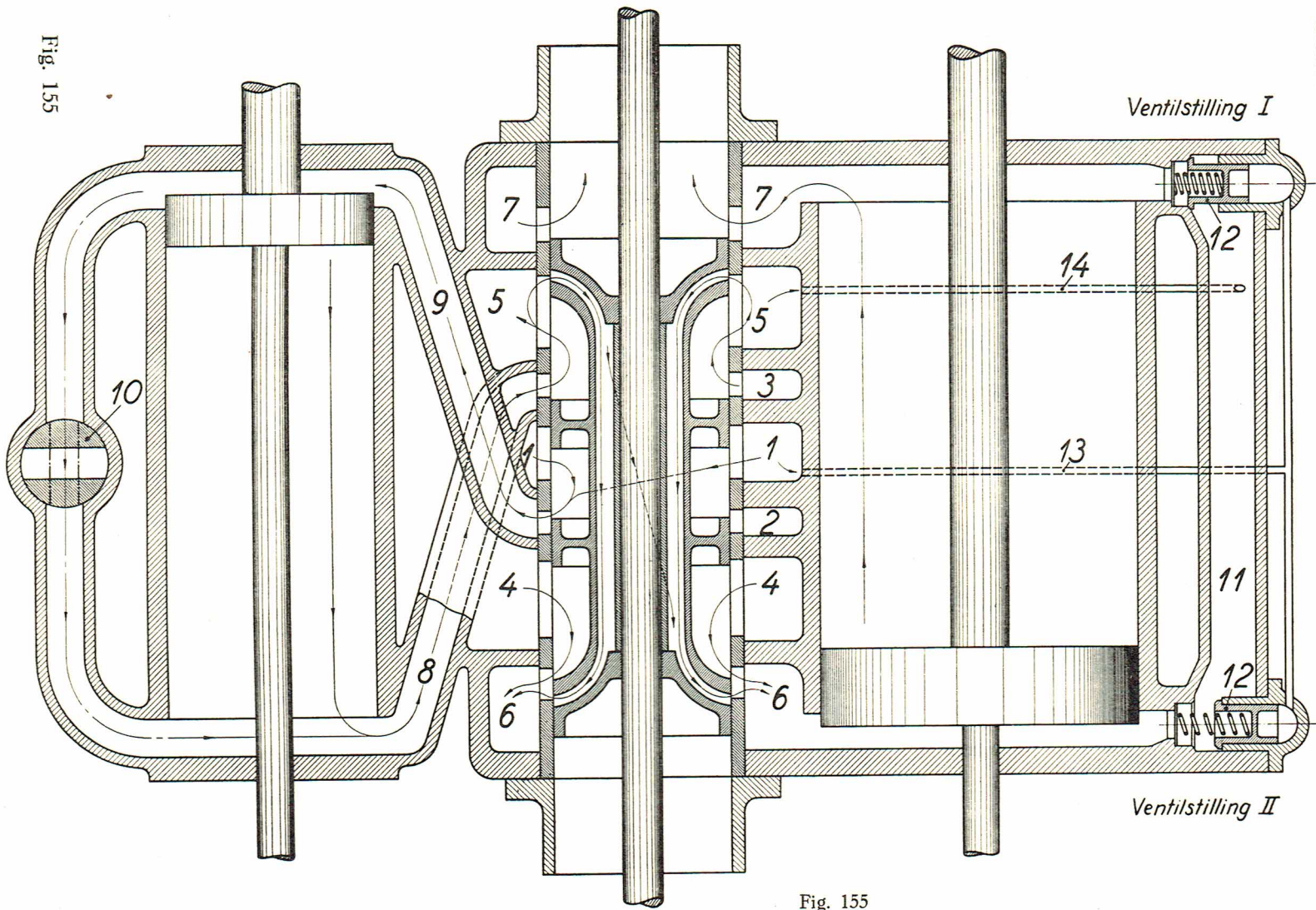

Fig. 155

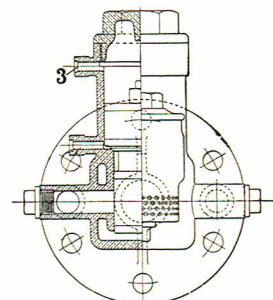
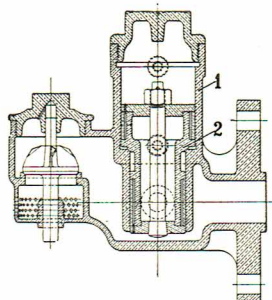

Fig. 157  
1:8

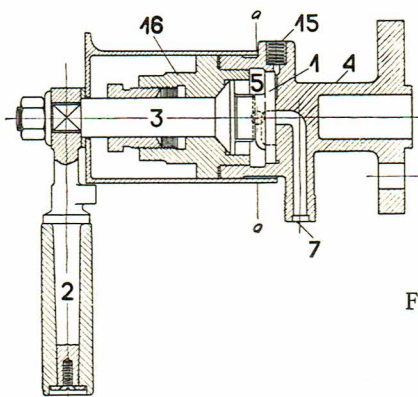

Fig. 158  
1:5

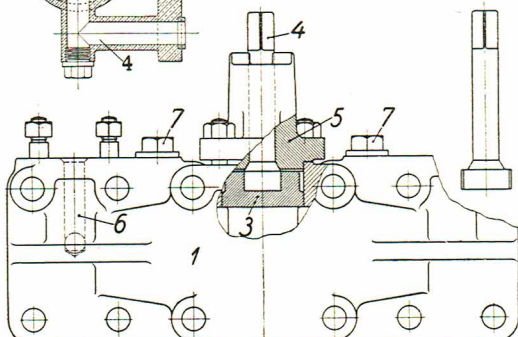
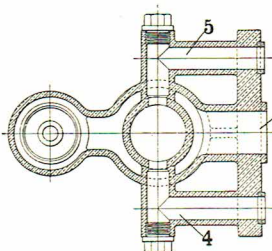
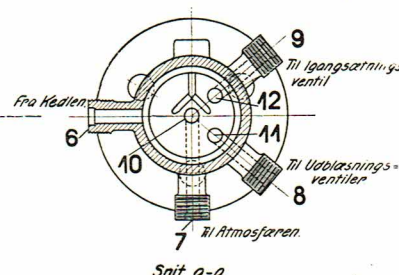

Fig. 156  
1:6

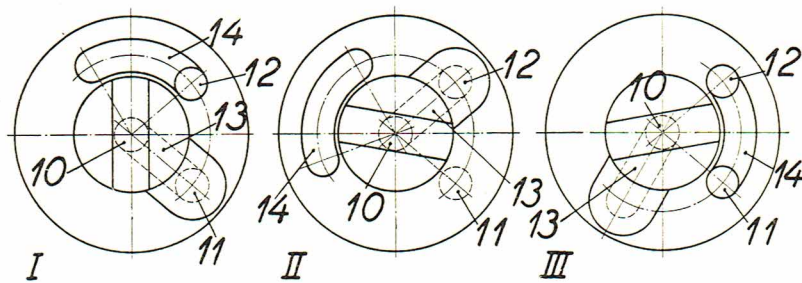

Fig. 158 a

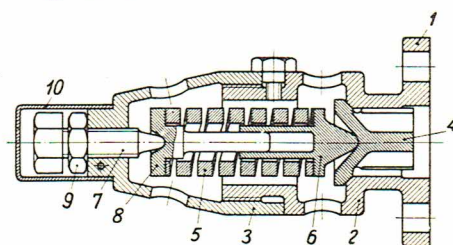

Fig. 159  
1:4

Fig. 156-159



Fig. 160—163

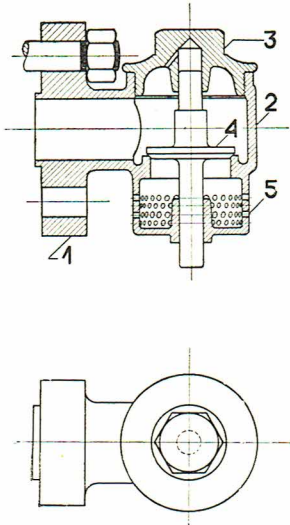

Fig. 160 1:5

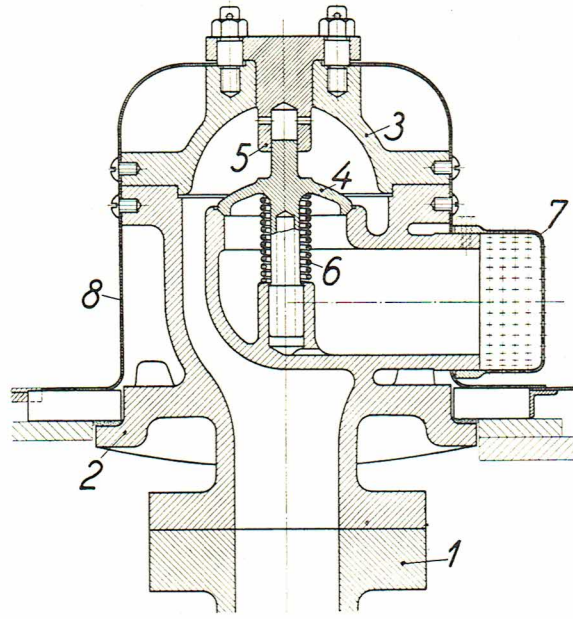

Fig. 163 1:5

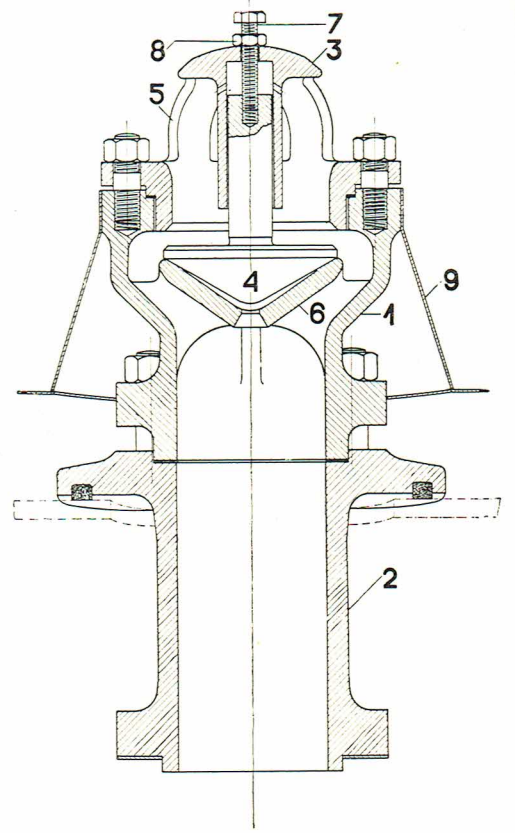

Fig. 162 1:5

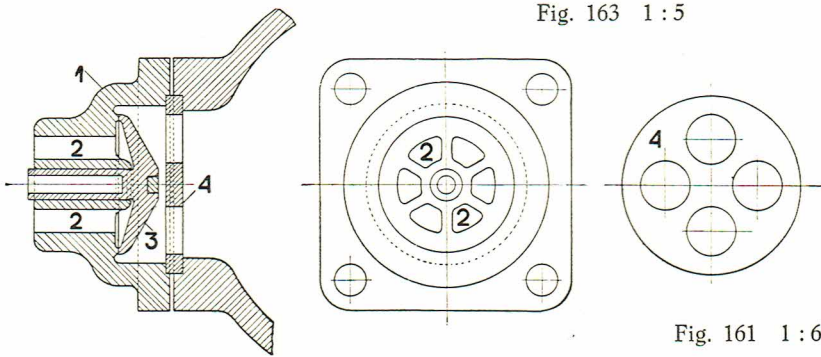

Fig. 161 1:6

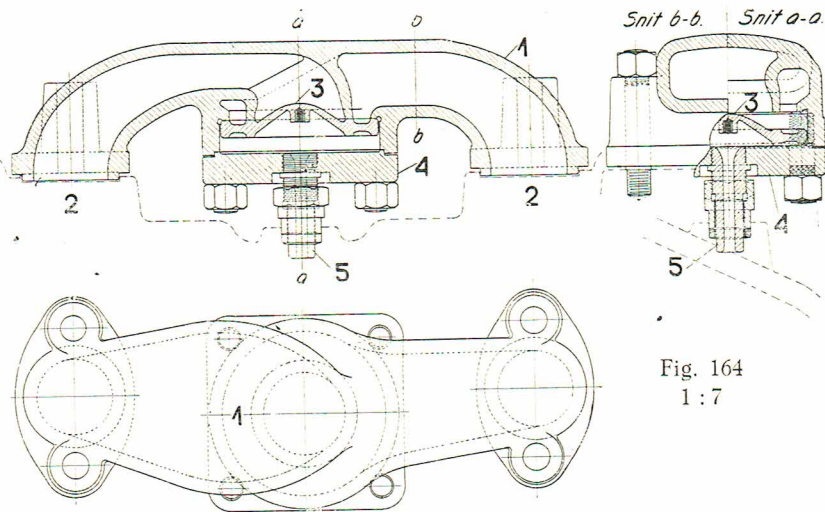

Fig. 164 1:7

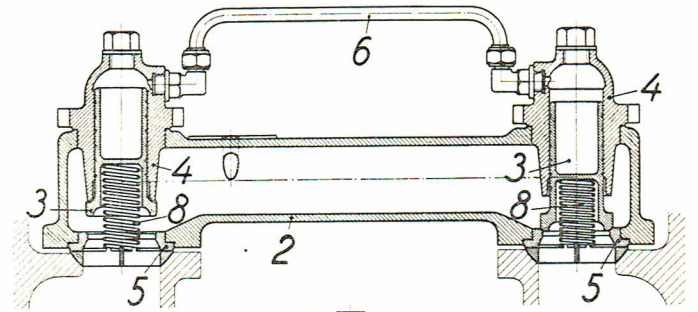

Fig. 165 1:10

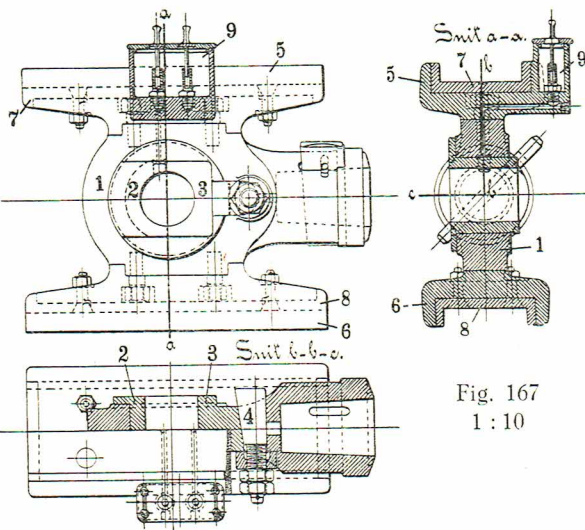

Fig. 167 1:10

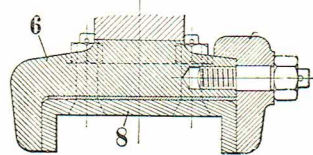

Fig. 167 a 1:5

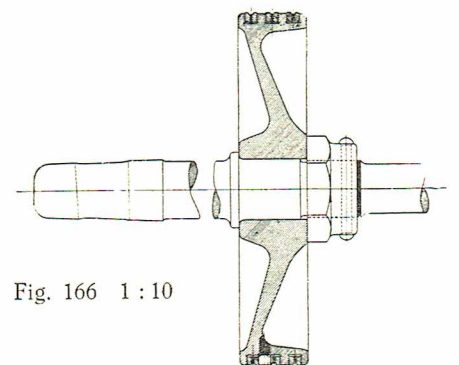

Fig. 166 1:10

Fig. 164—167 a



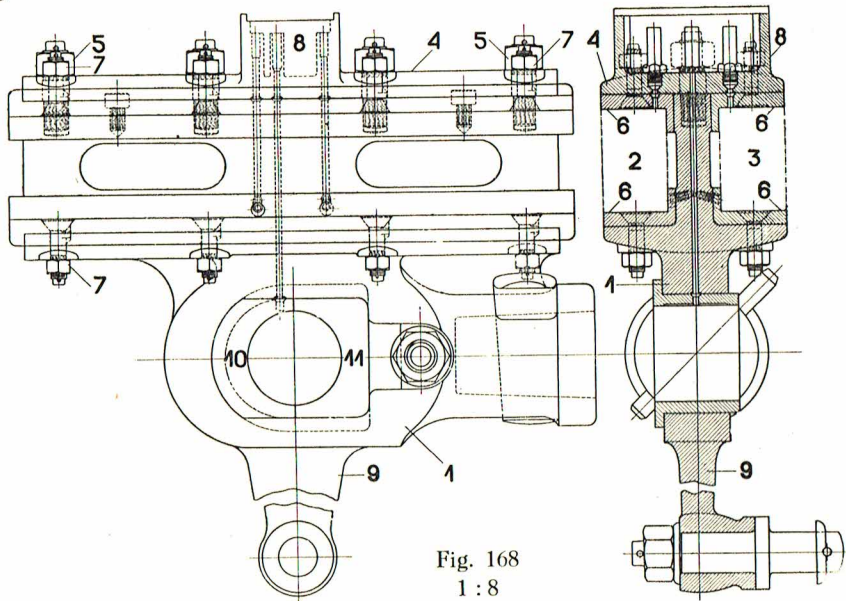

Fig. 168  
1:8

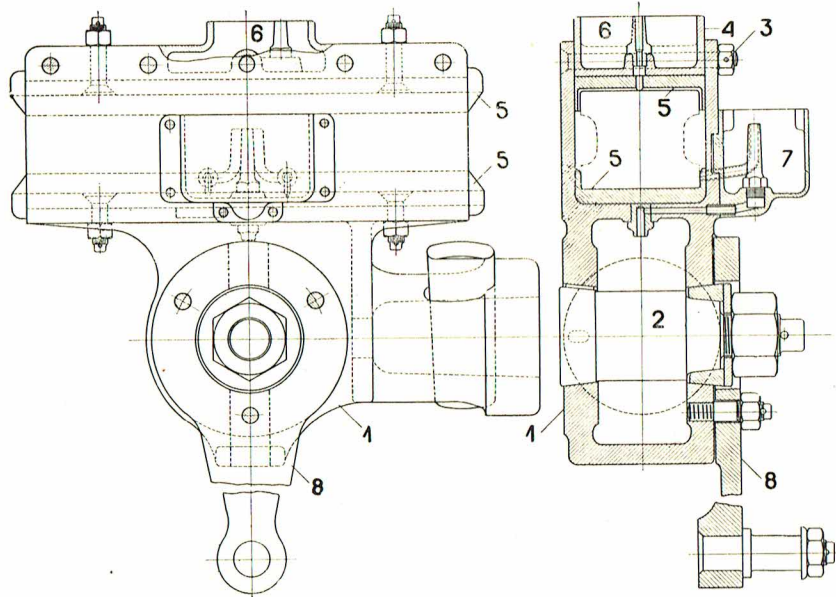

Fig. 169  
1:7.5

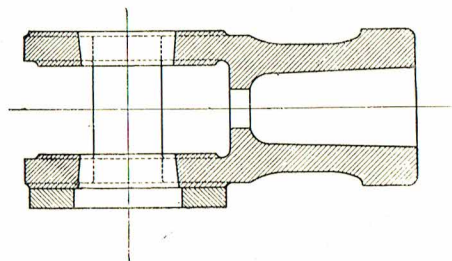

Fig. 168—169

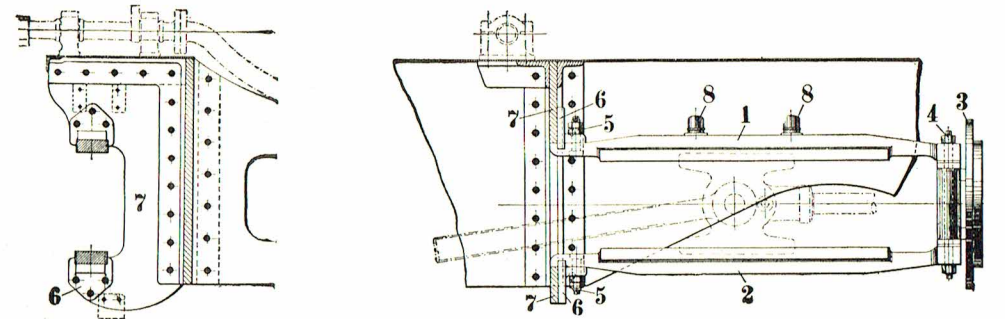

Fig. 170 1:25

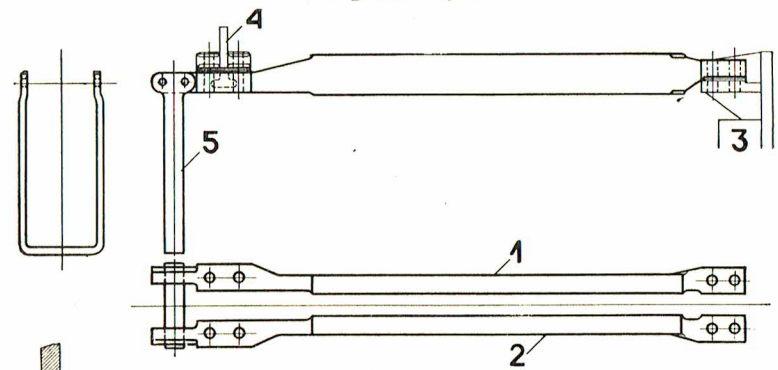

Fig. 171 1:20

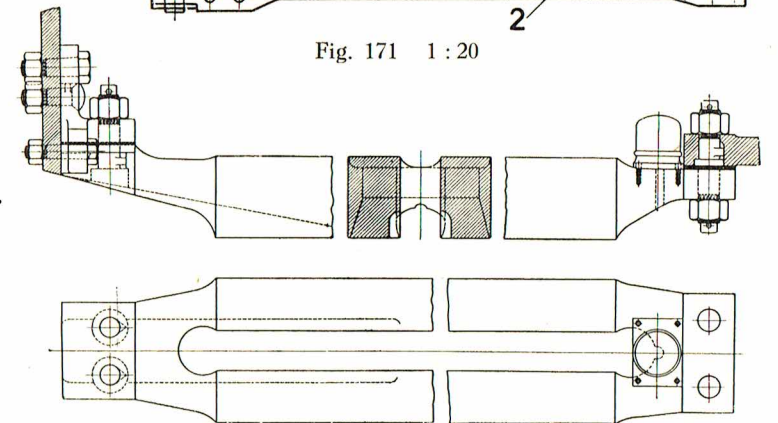

Fig. 172 1:10

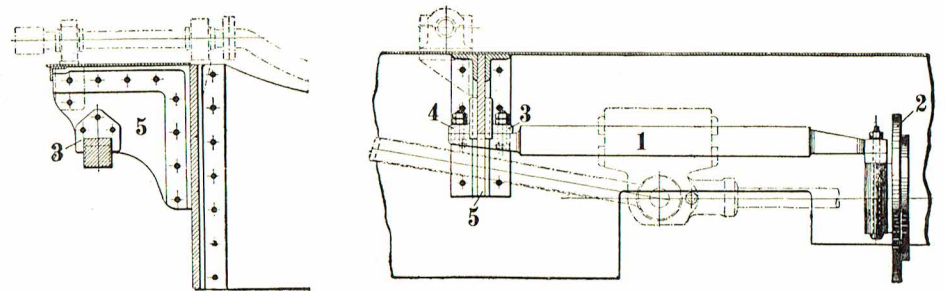

Fig. 173 1:25

Fig. 170—173



Fig. 174-177

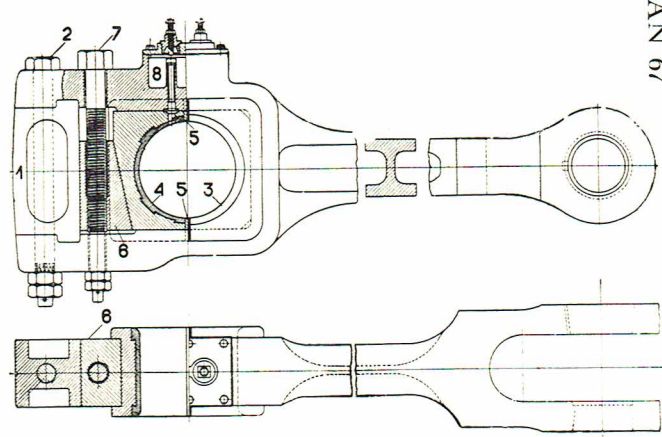
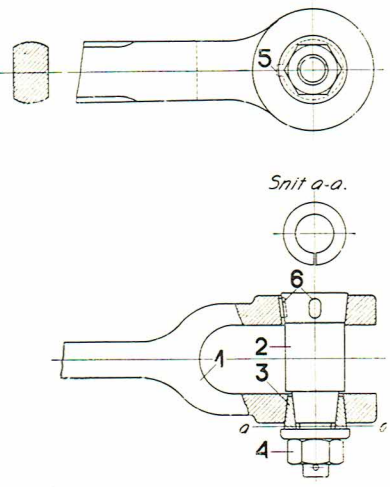
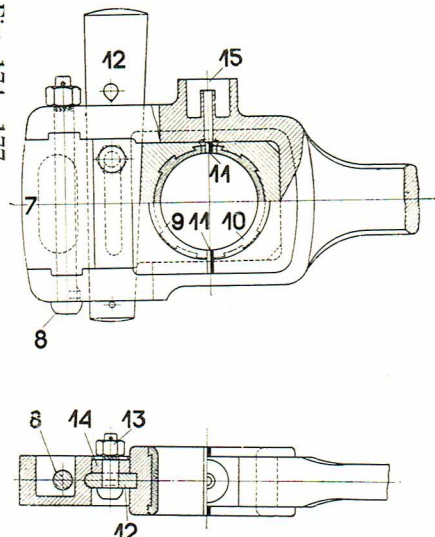

Fig. 175 1:10

Fig. 174 1:7,5

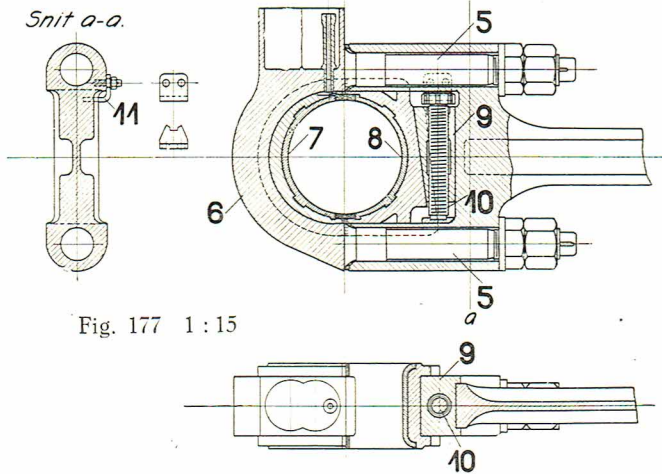

Fig. 177 1:15

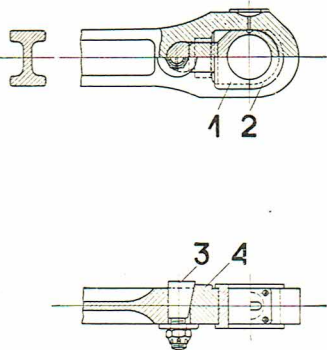

Fig. 176 1:10

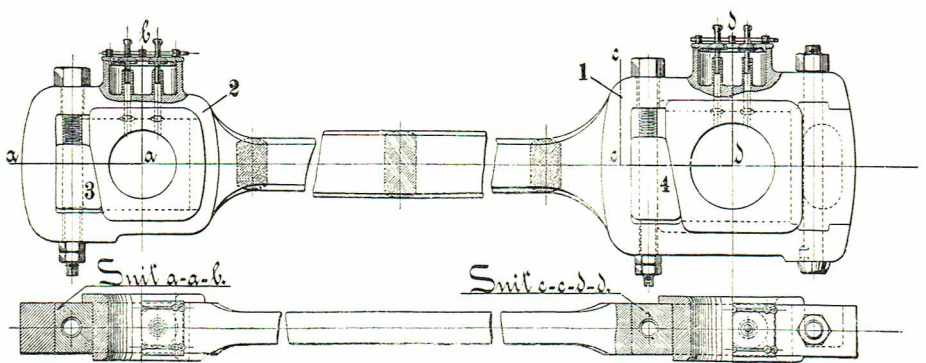

Fig. 179 1:10

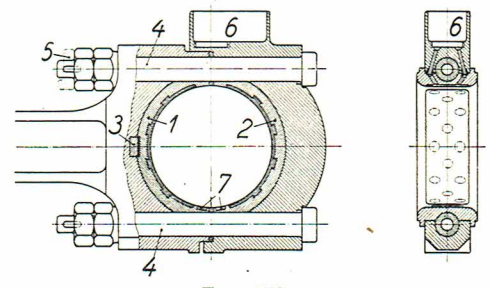

Fig. 178 1:15

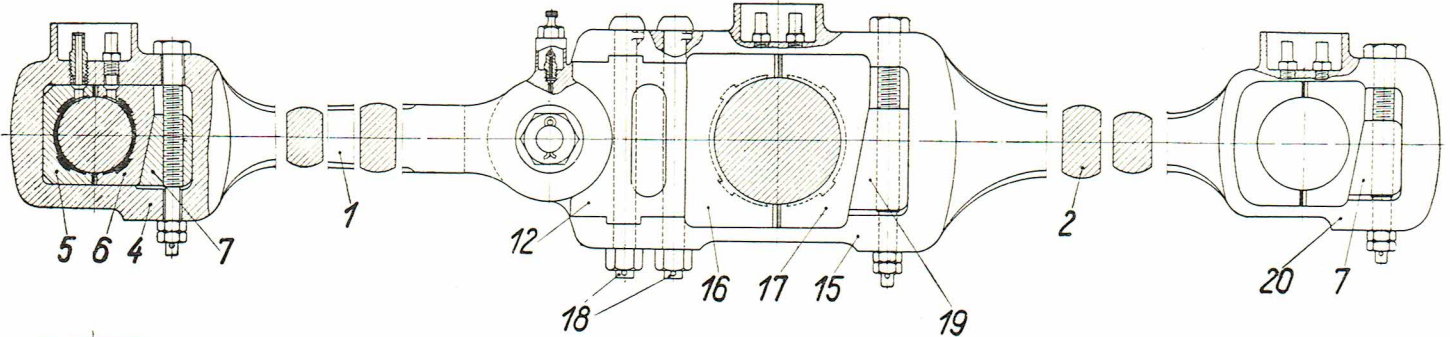

Fig. 180 1:9

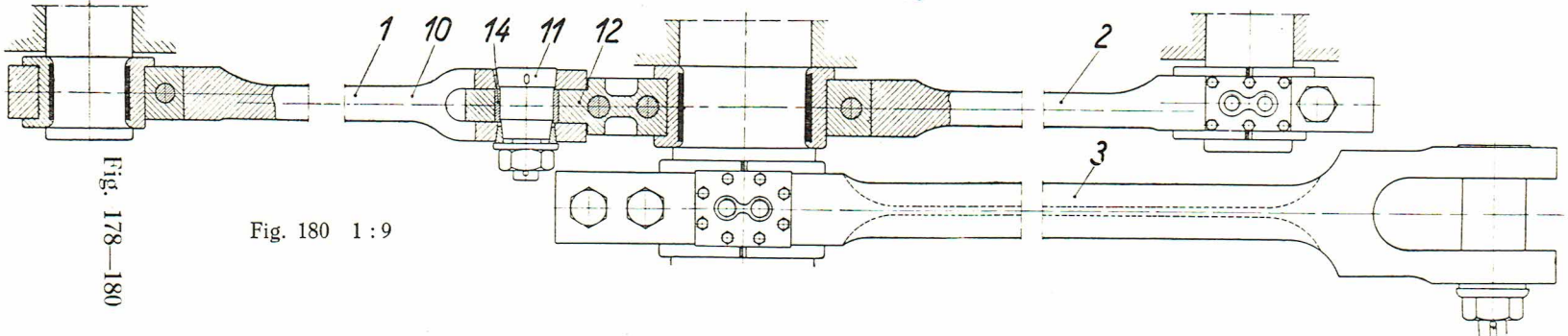

Fig. 178-180



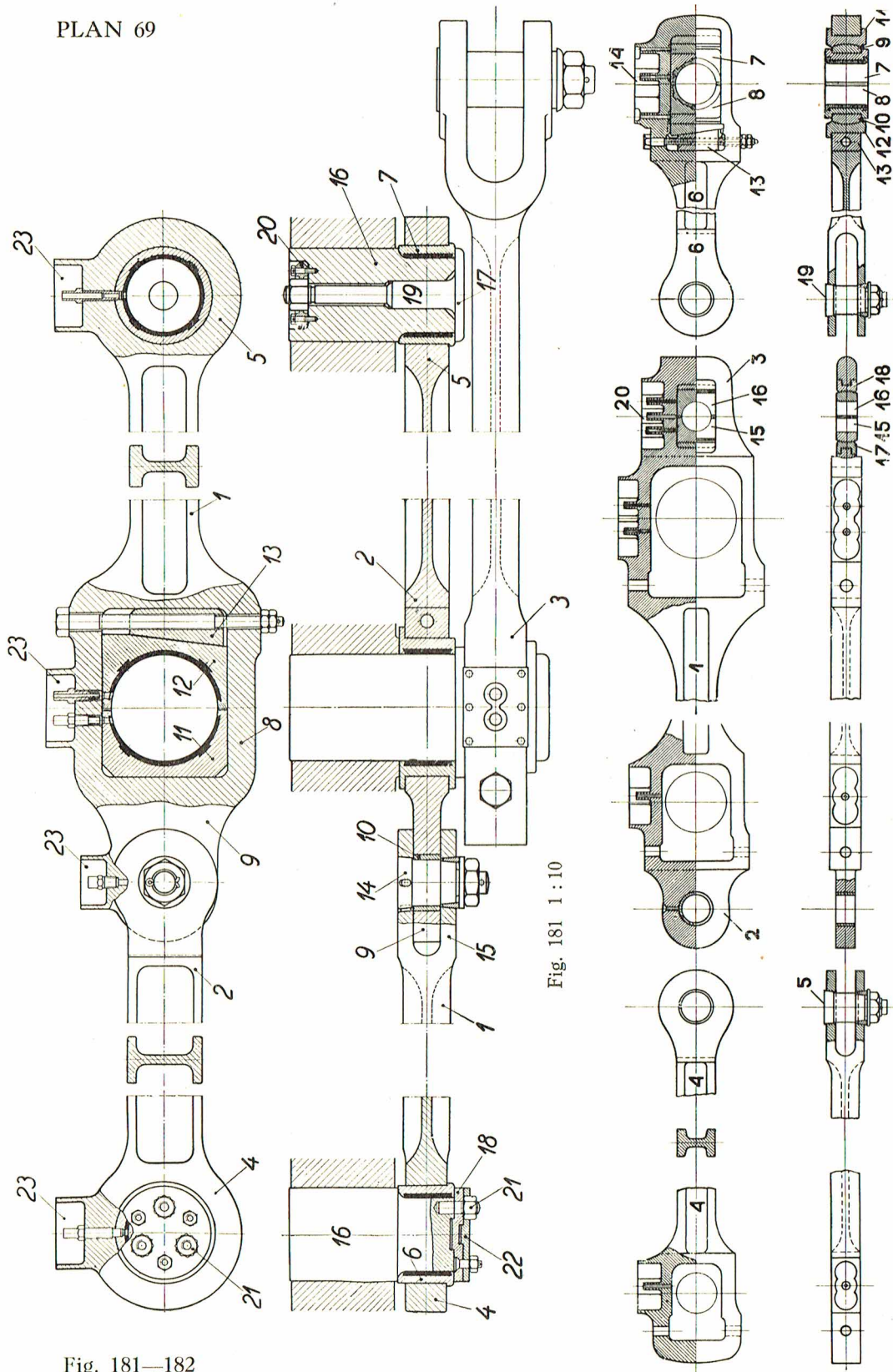

Fig. 181—182

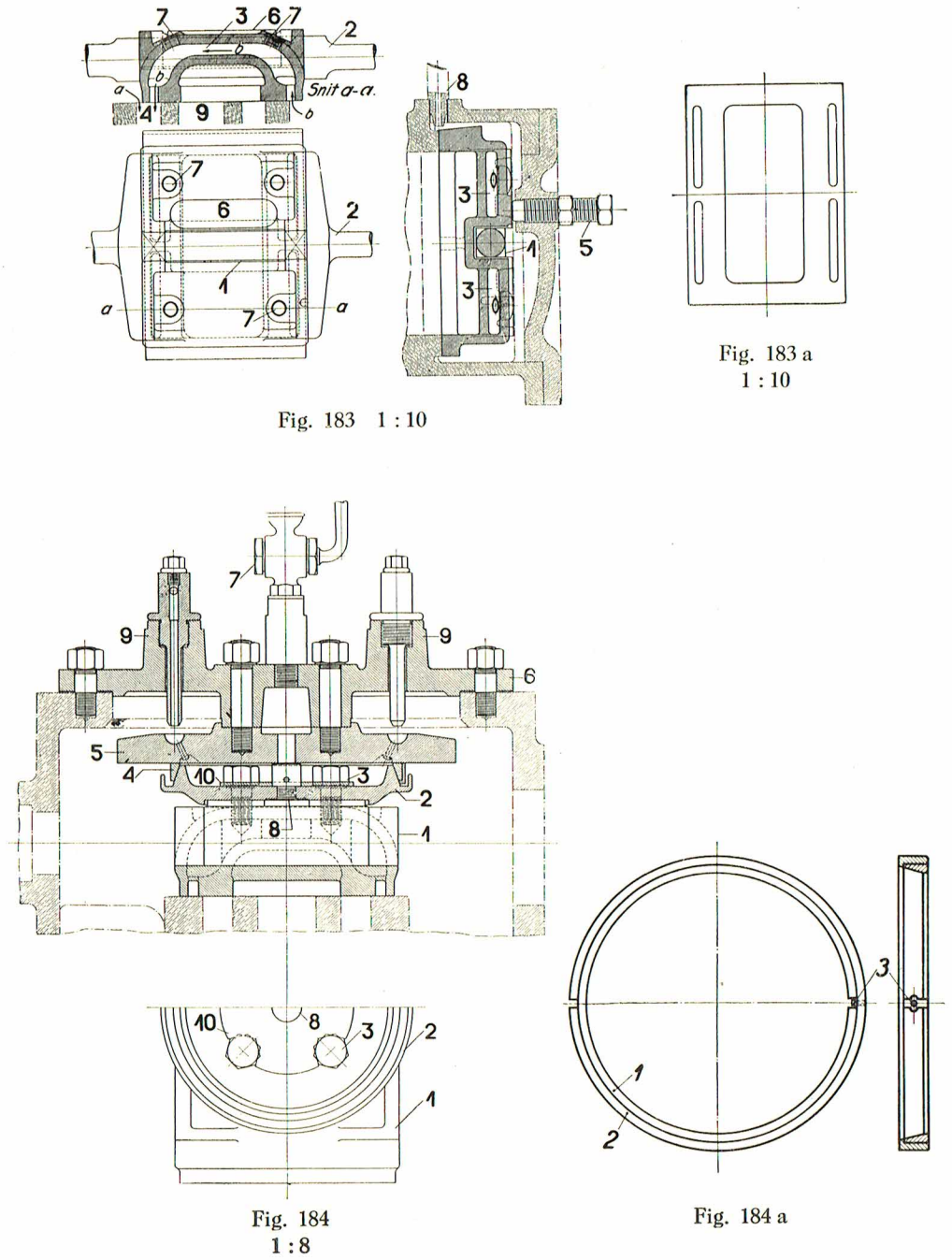

Fig. 183—184 a



Fig. 185—188

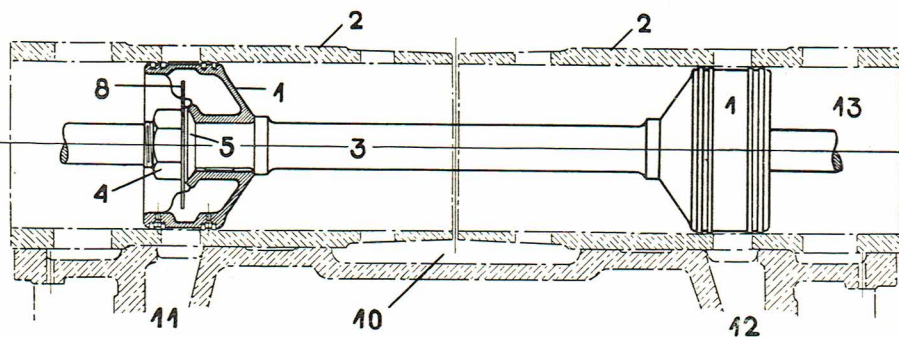

Fig. 187 1:10

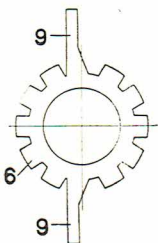
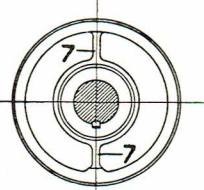

Fig. 187 a  
1:5

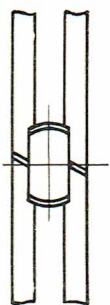

Fig. 188  
1:2

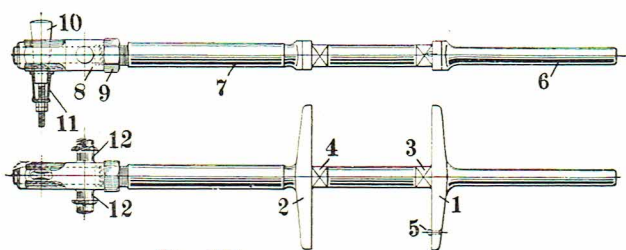

Fig. 185  
1:5

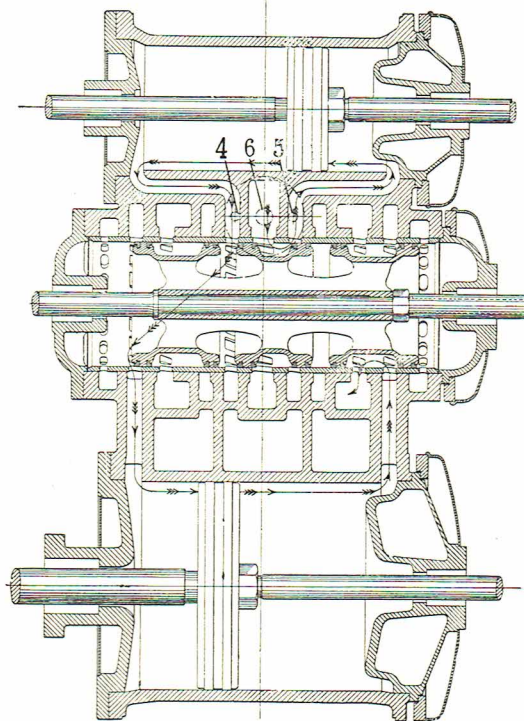

Fig. 186 1:20

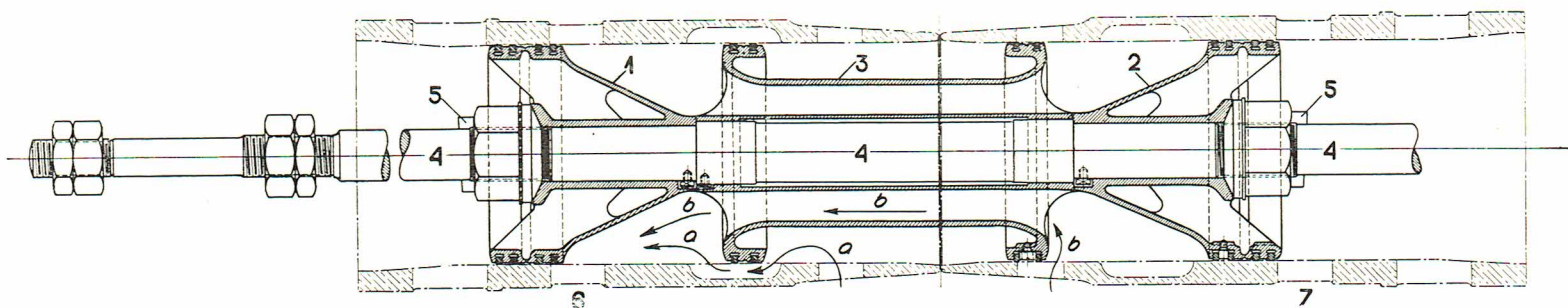

Fig. 189 1:7,5

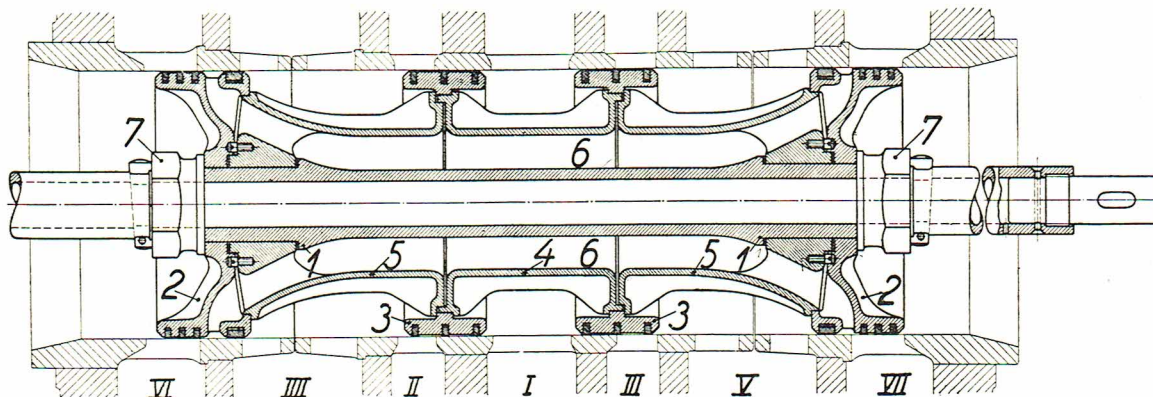
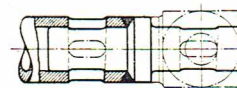

Fig. 190 1:8

Fig. 189—190



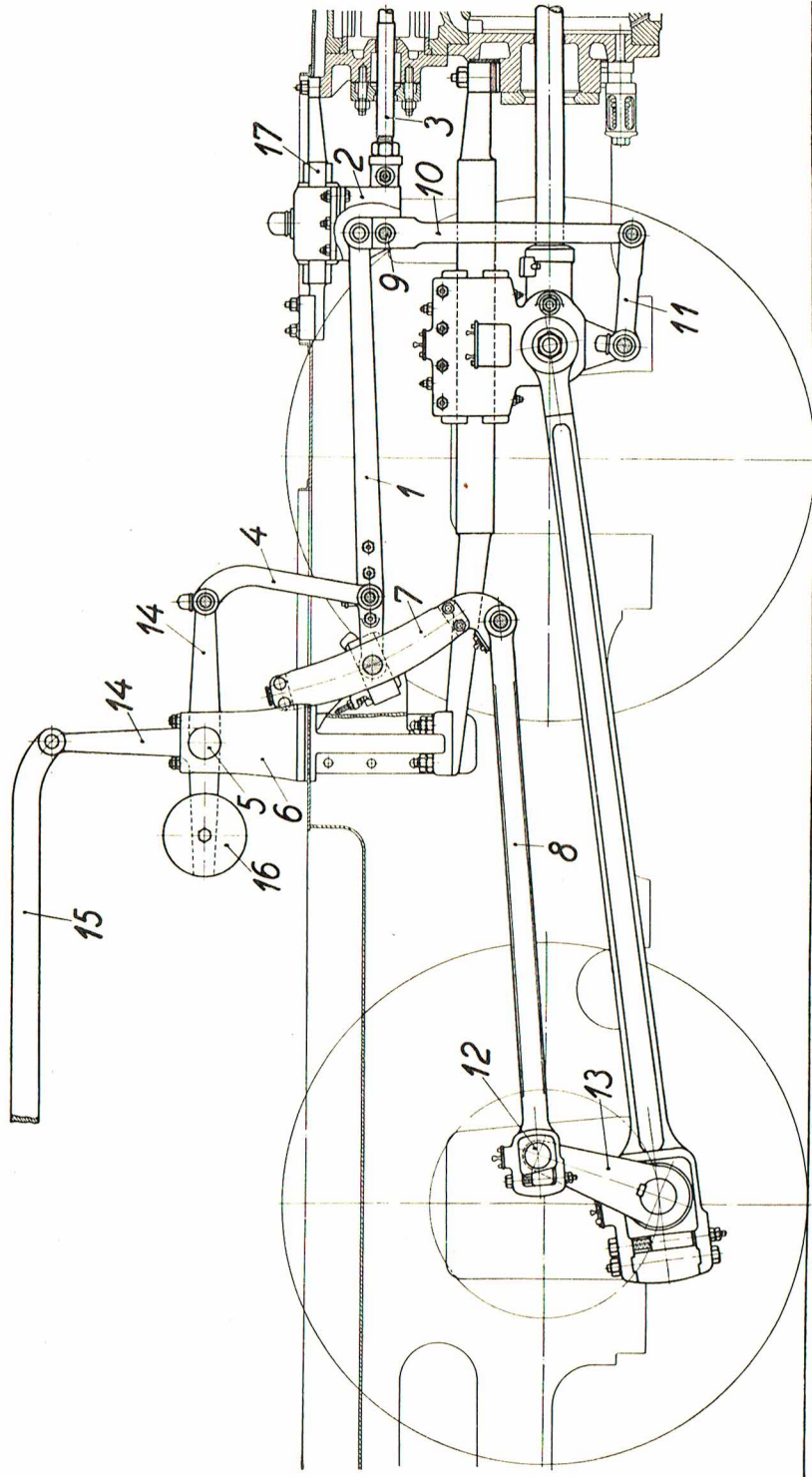

Fig. 191

Fig. 191 1 : 20

Fig. 192

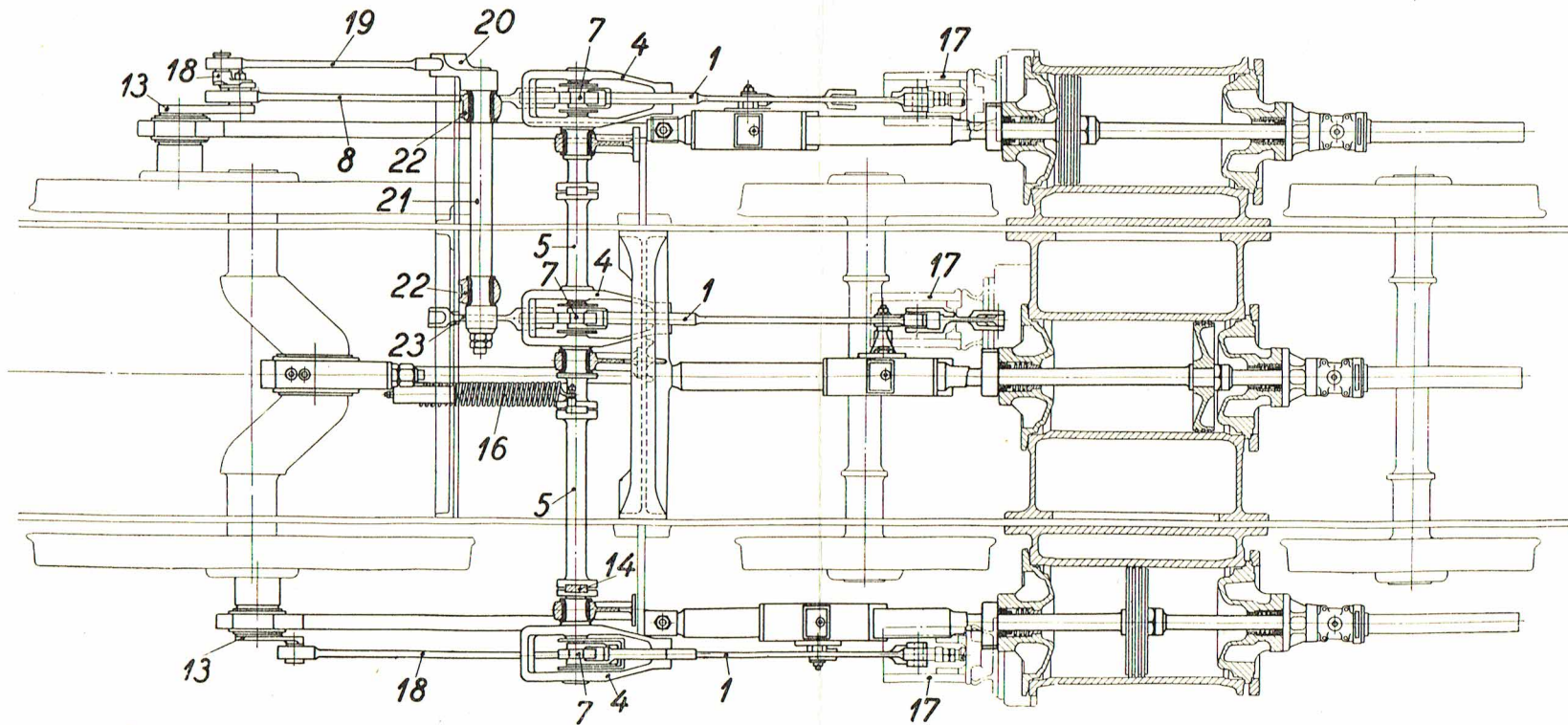
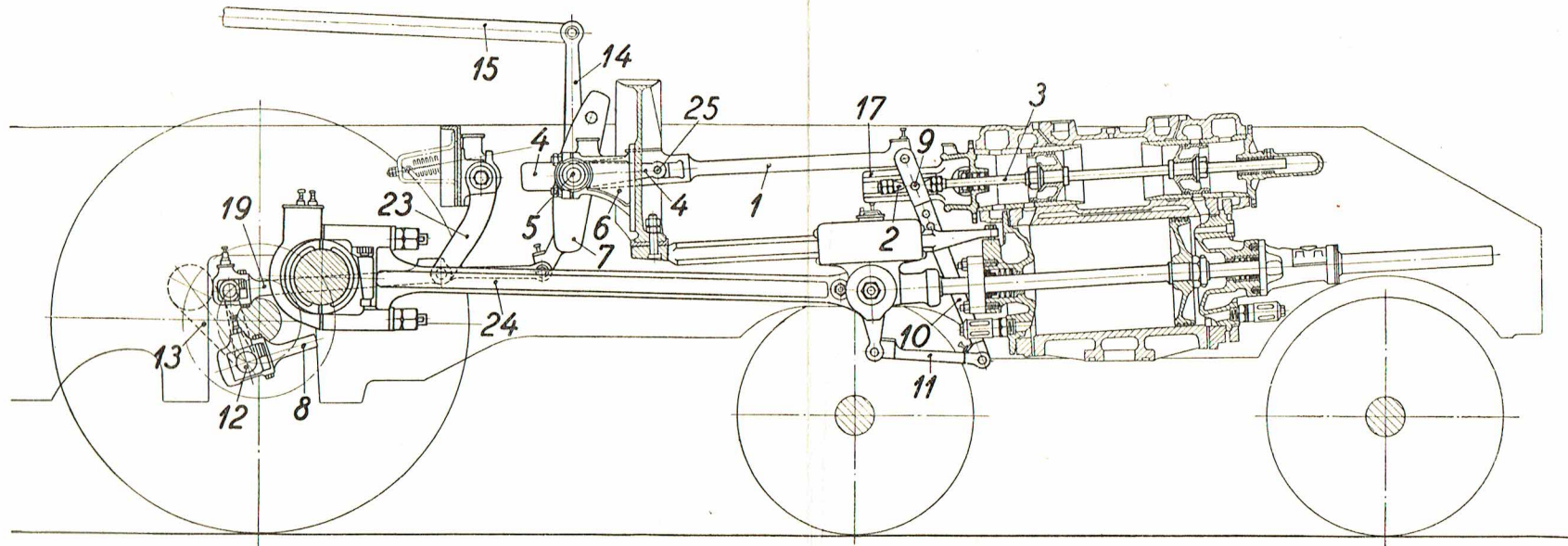

Fig. 192 1:30



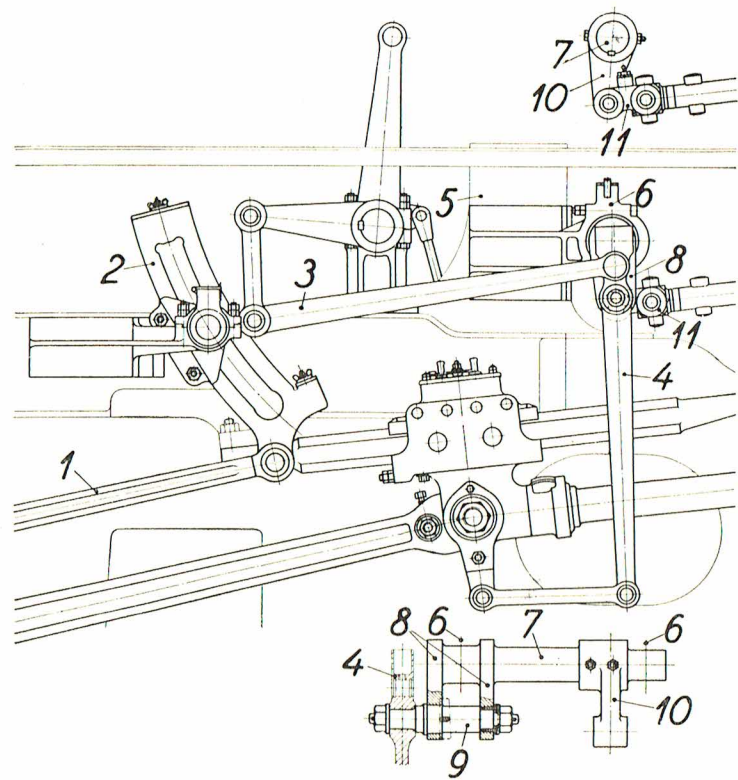

Fig. 193 1 : 20

Fig. 193

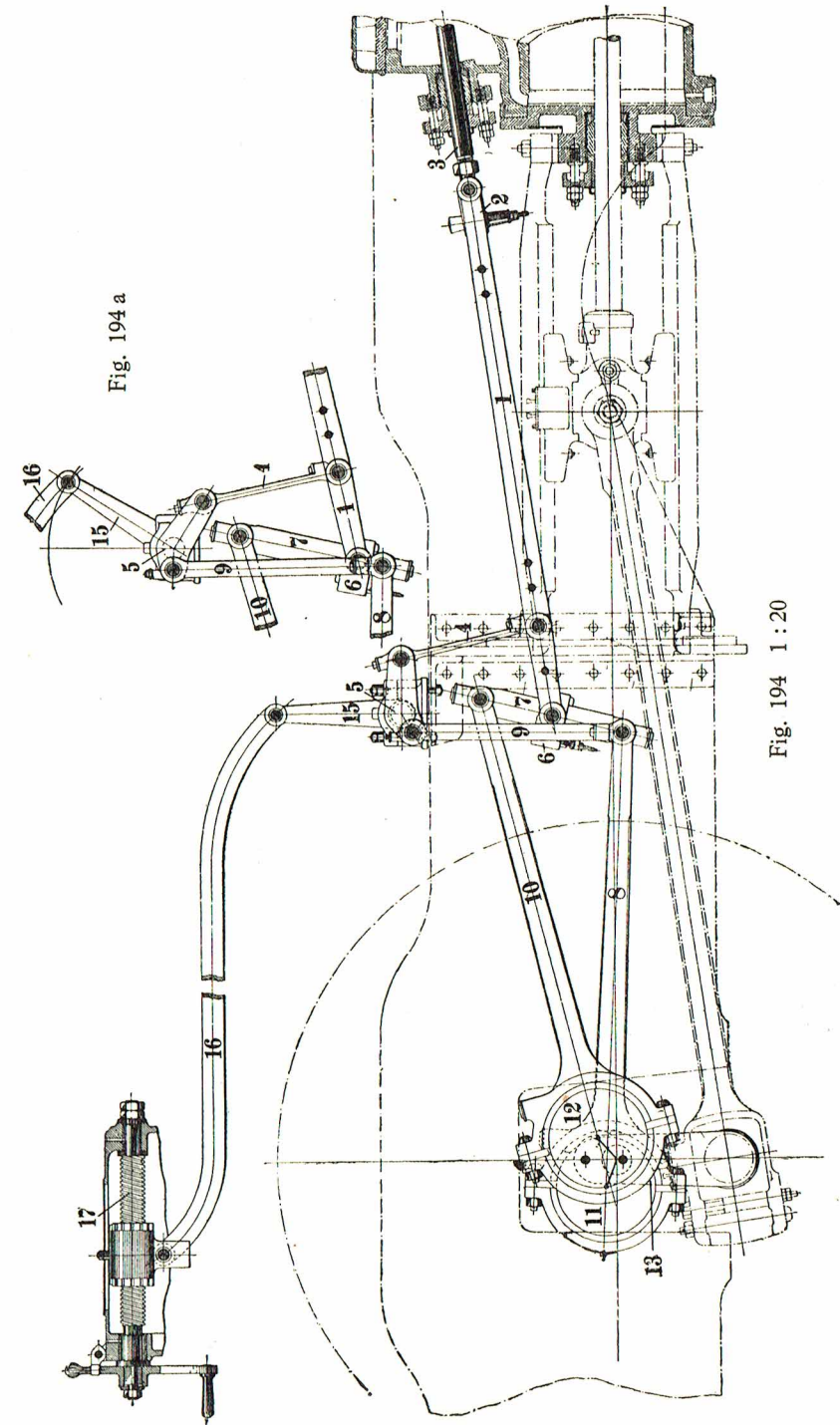

Fig. 194 a

Fig. 194 1 : 20

Fig. 194—194 a

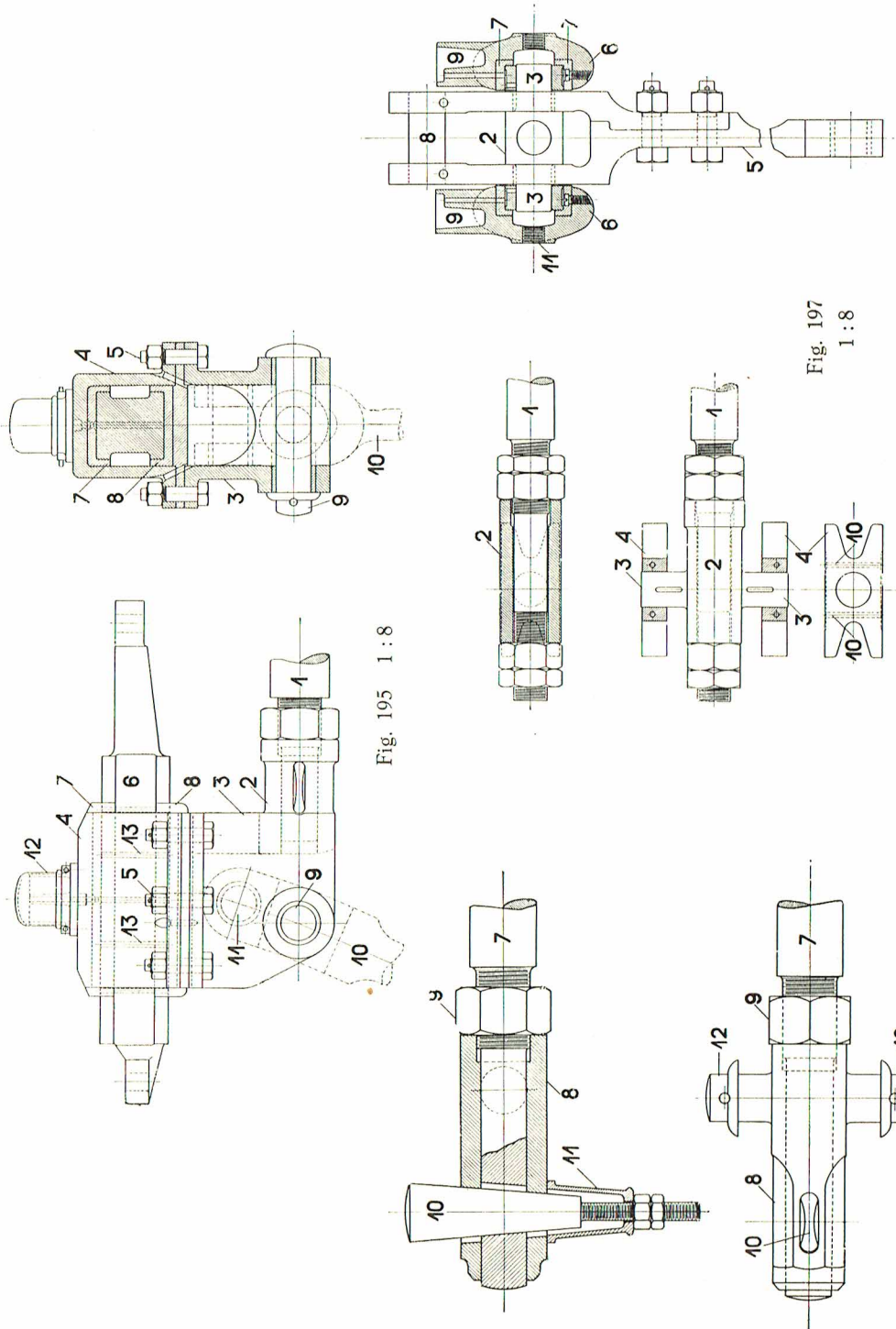

Fig. 195—197

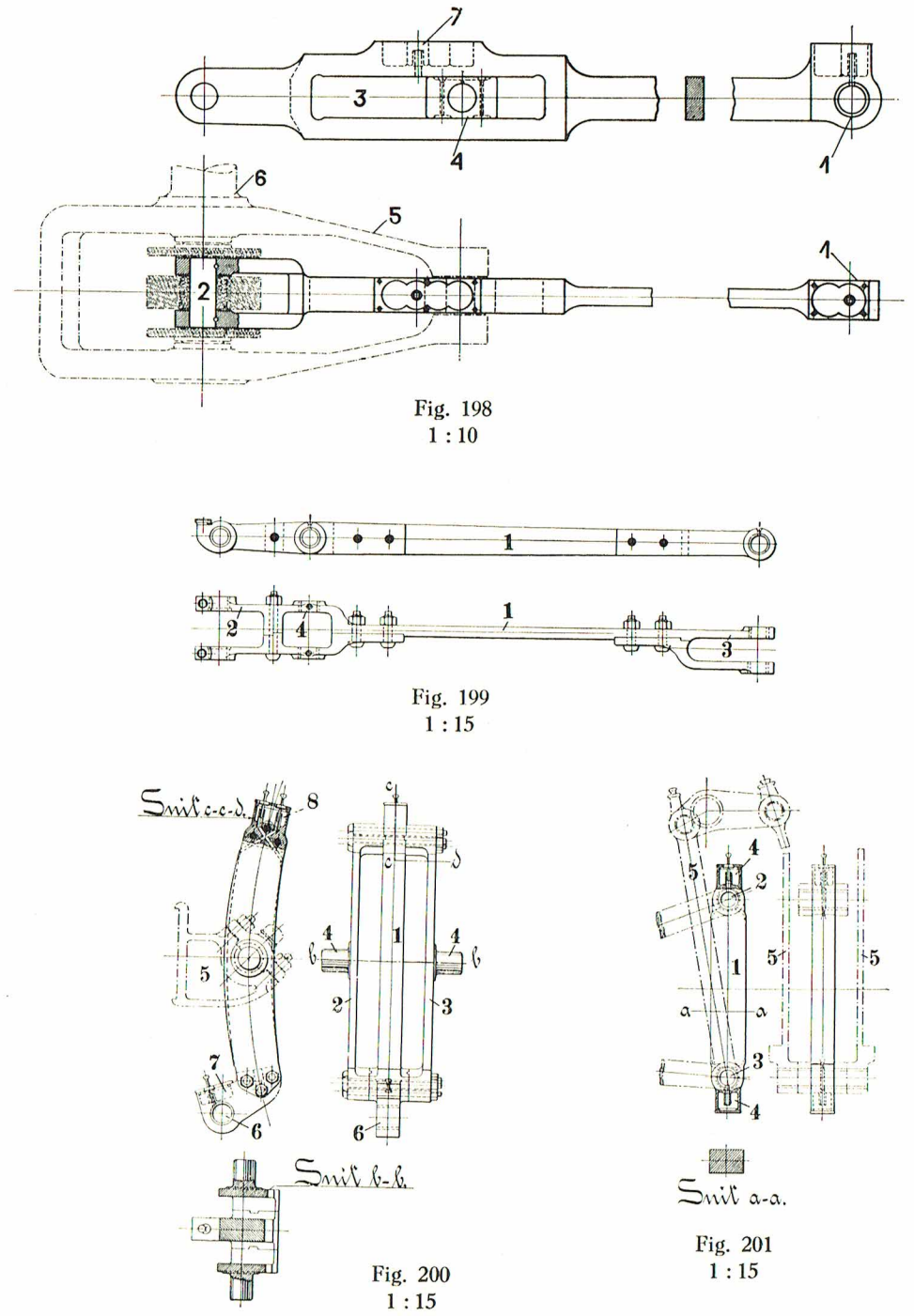

Fig. 198—201



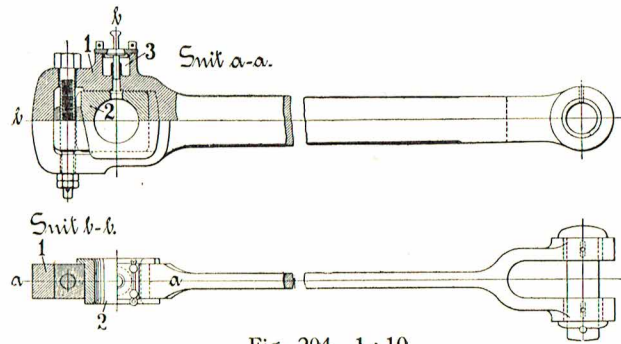

Fig. 204 1:10

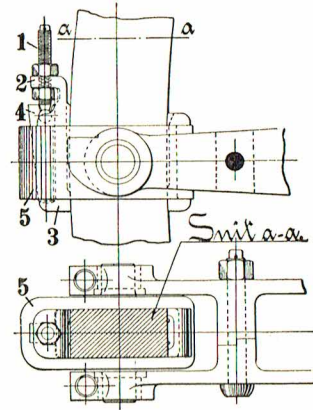

Fig. 202 1:7,5

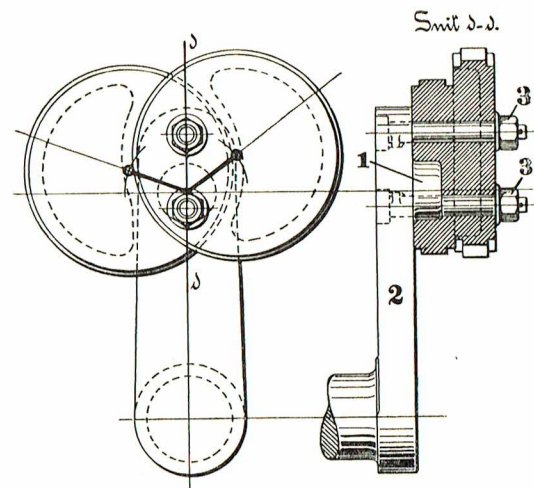

Fig. 205 1:10

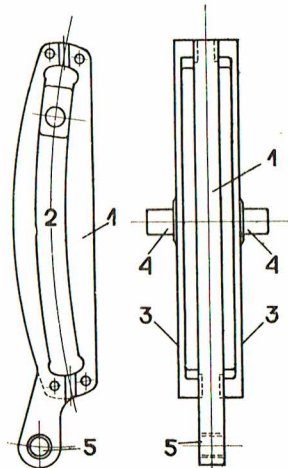

Fig. 203 1:15

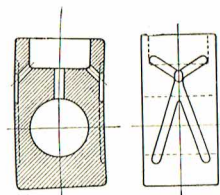

Fig. 203 a 1:5

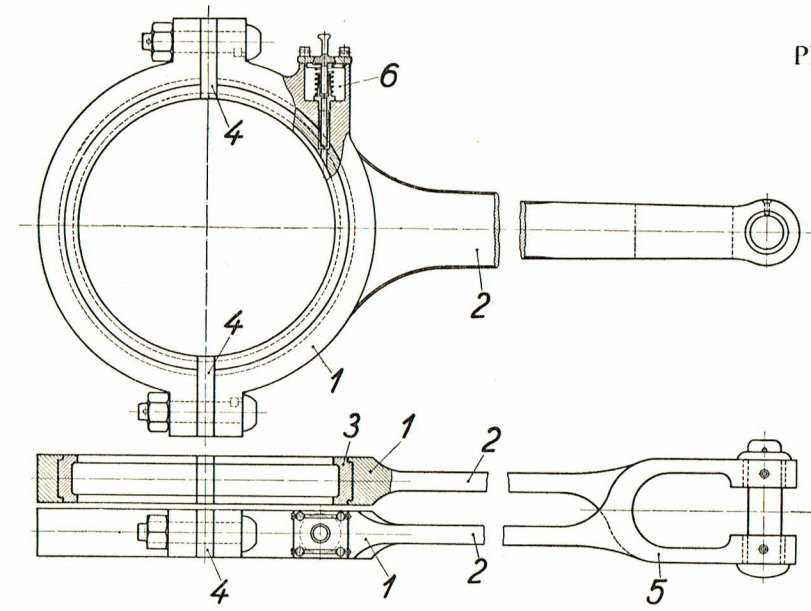

Fig. 206 1:8

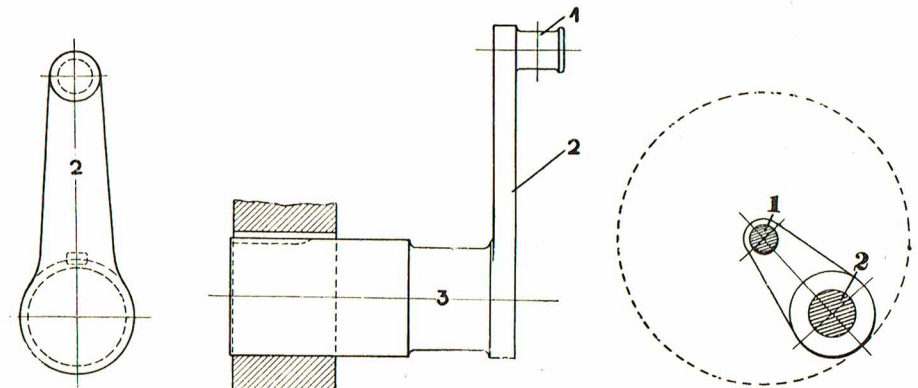

Fig. 208 1:12,5

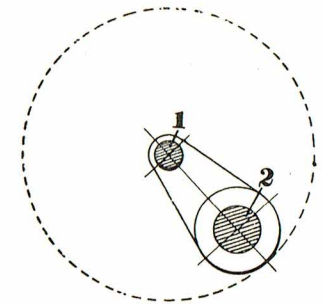

Fig. 207

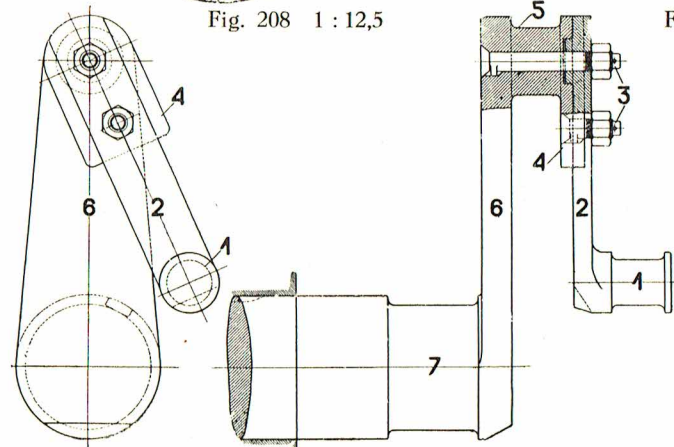

Fig. 209 1:10

Fig. 210—211 a

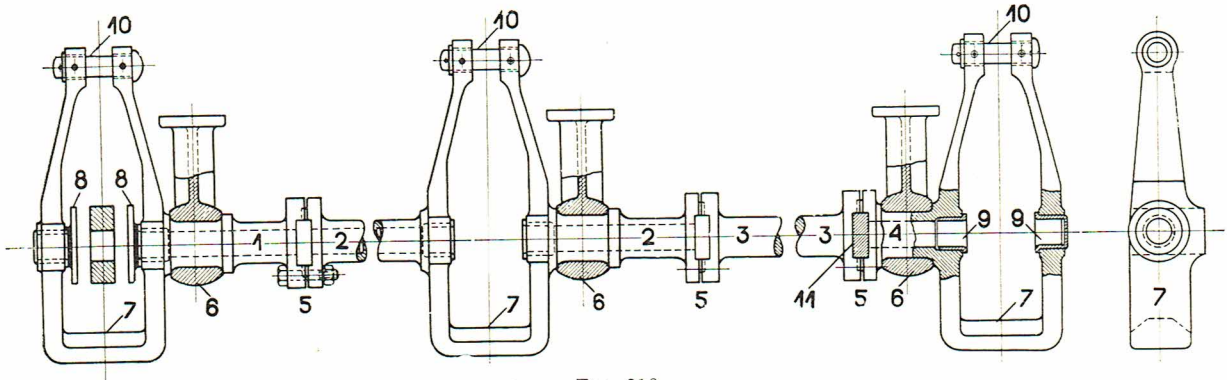

Fig. 210  
1 : 15

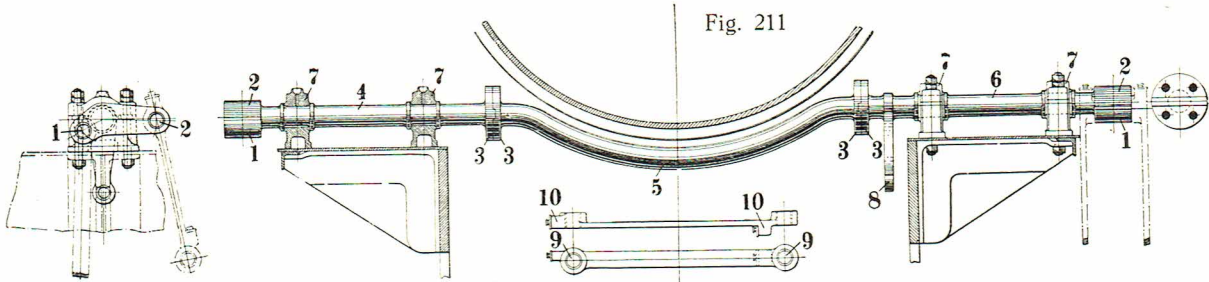

Fig. 211 a

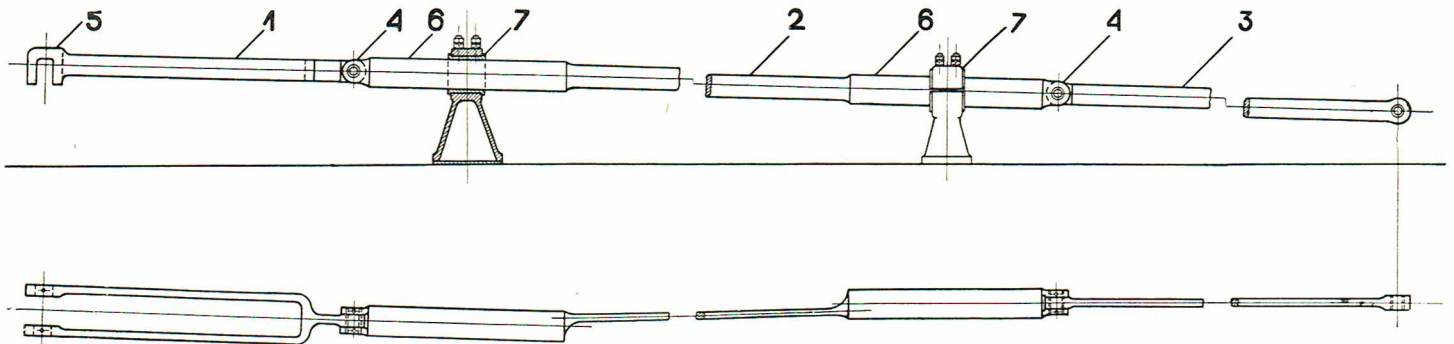

Fig. 212 1 : 25

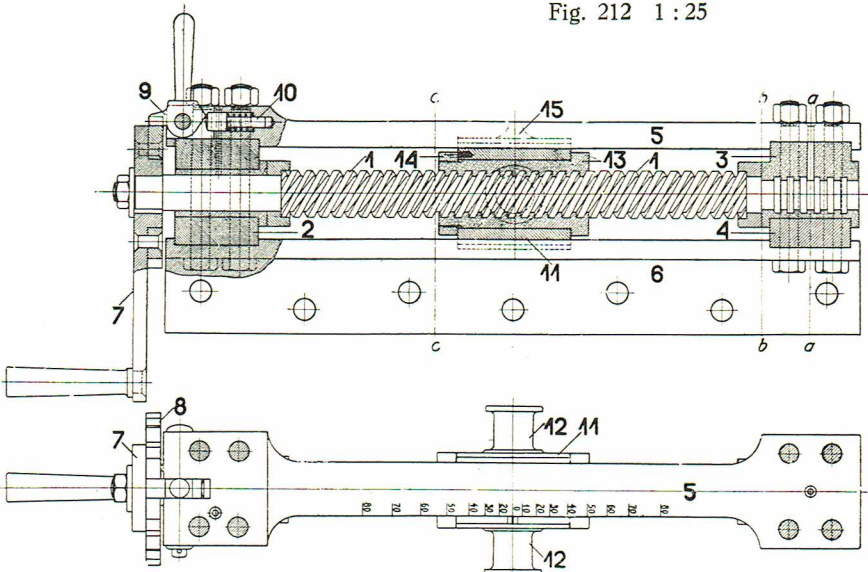

Fig. 213 1 : 8

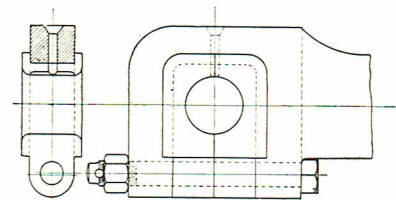
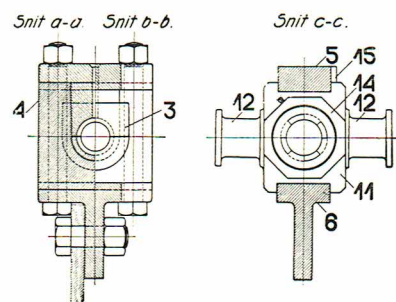

Fig. 212 a



Snit a-a Snit b-b. Snit c-c.

Fig. 212—213



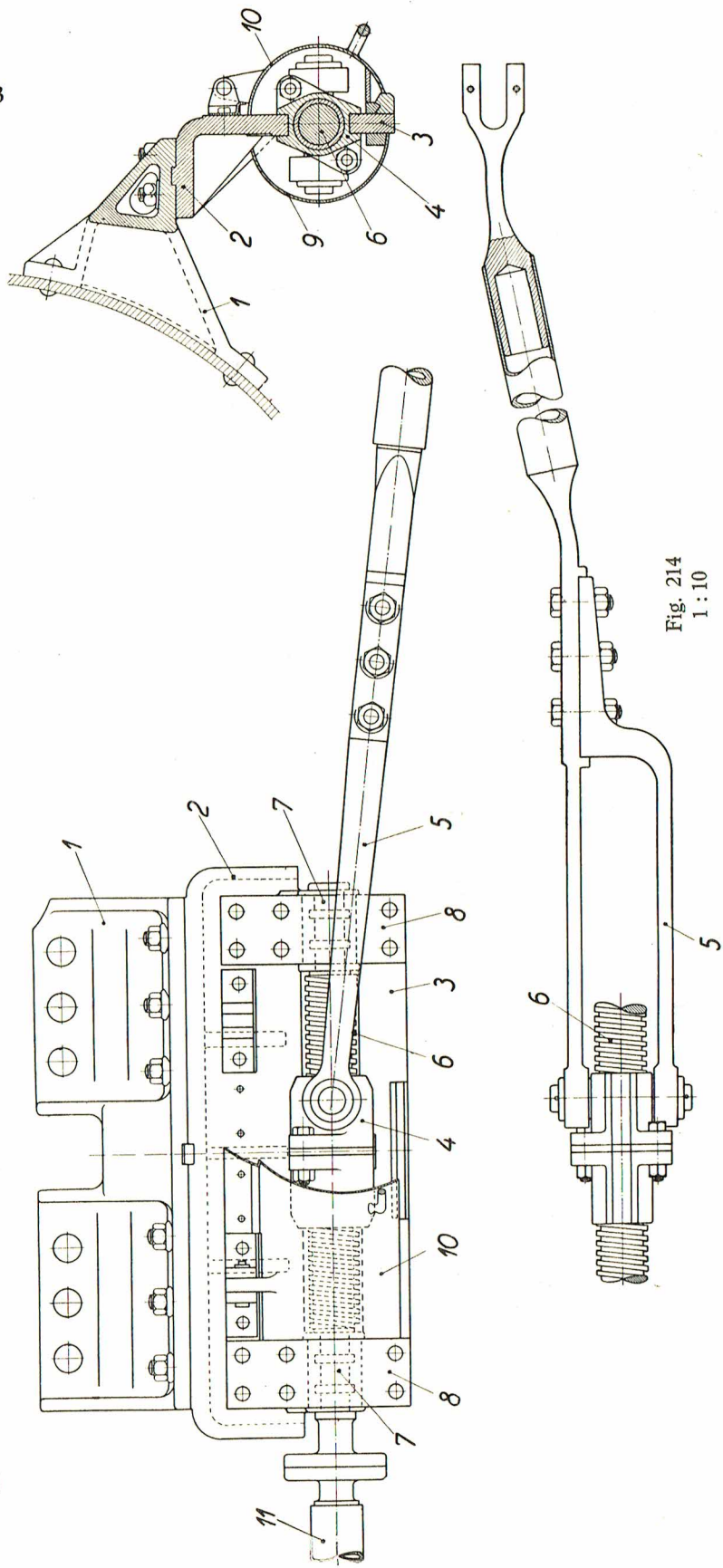

Fig. 214

Fig. 214  
1:10

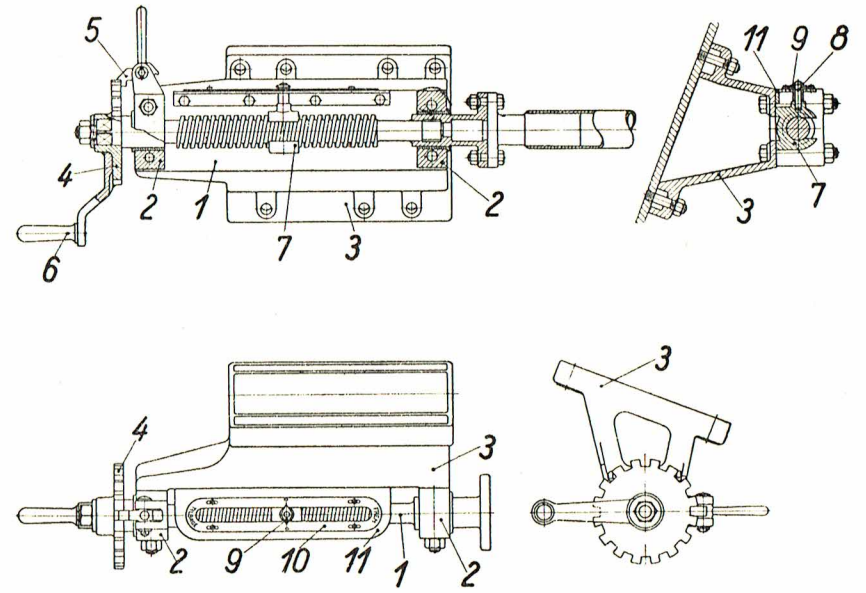

Fig. 215  
1:15

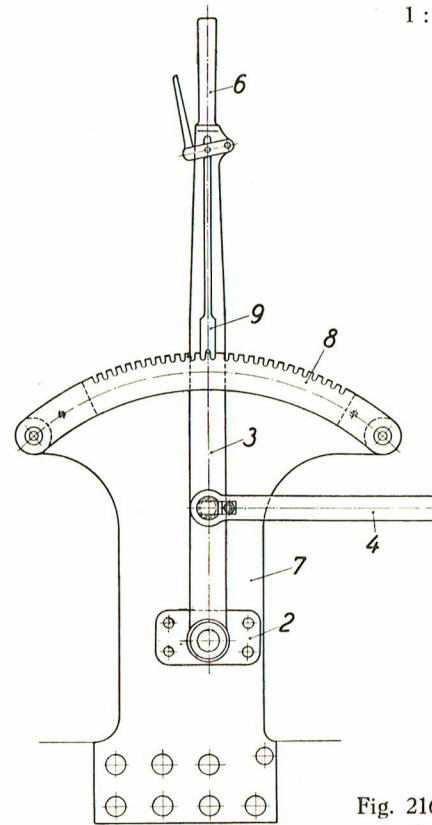

Fig. 216  
1:5

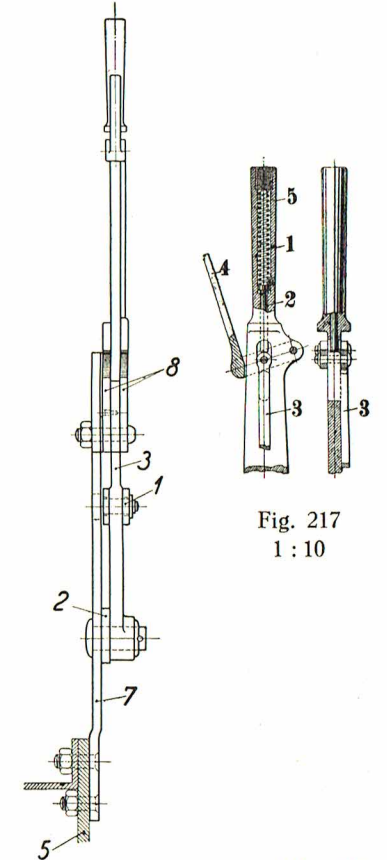

Fig. 217  
1:10

Fig. 215—217

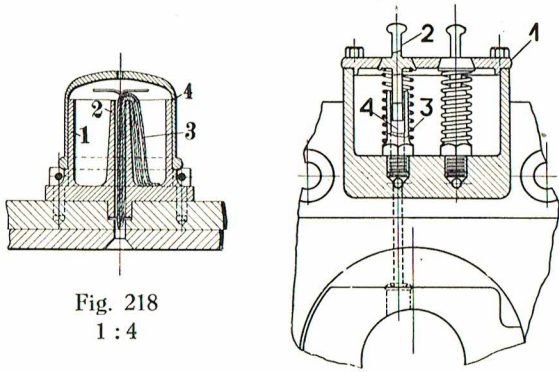

Fig. 219 1:5

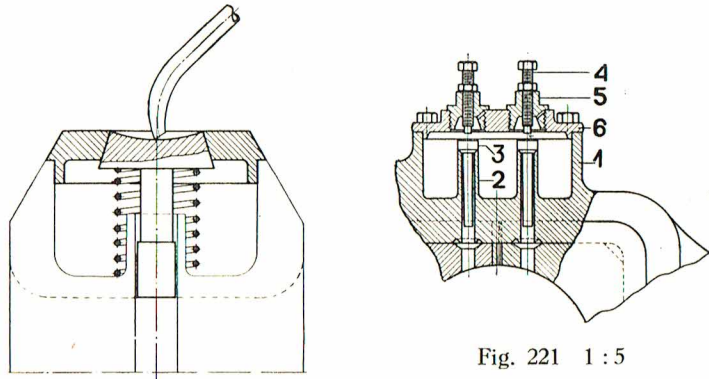

Fig. 220

Fig. 221 1:5

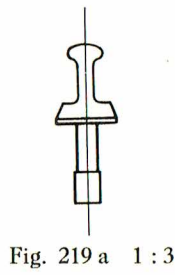

Fig. 219 a 1:3

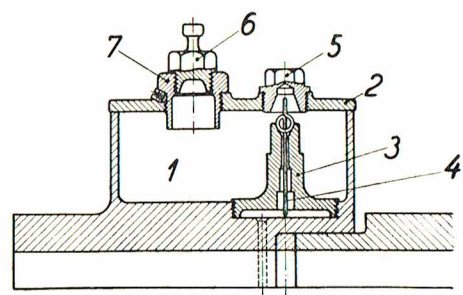

Fig. 222 1:5

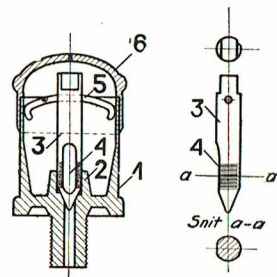

Fig. 223 1:4

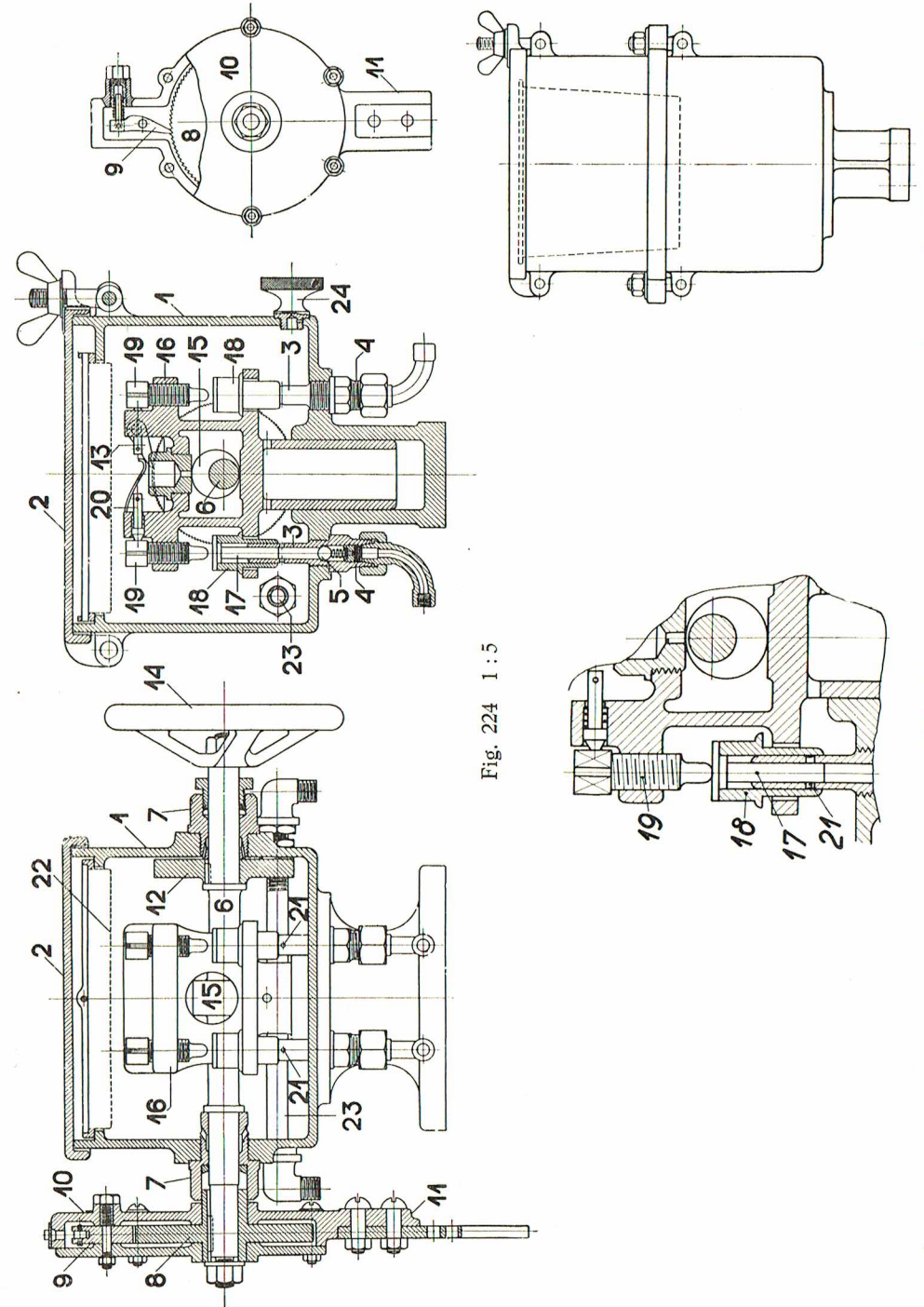

Fig. 224 1:5

Fig. 224 a 1:3

Fig. 224 b 1:7,5



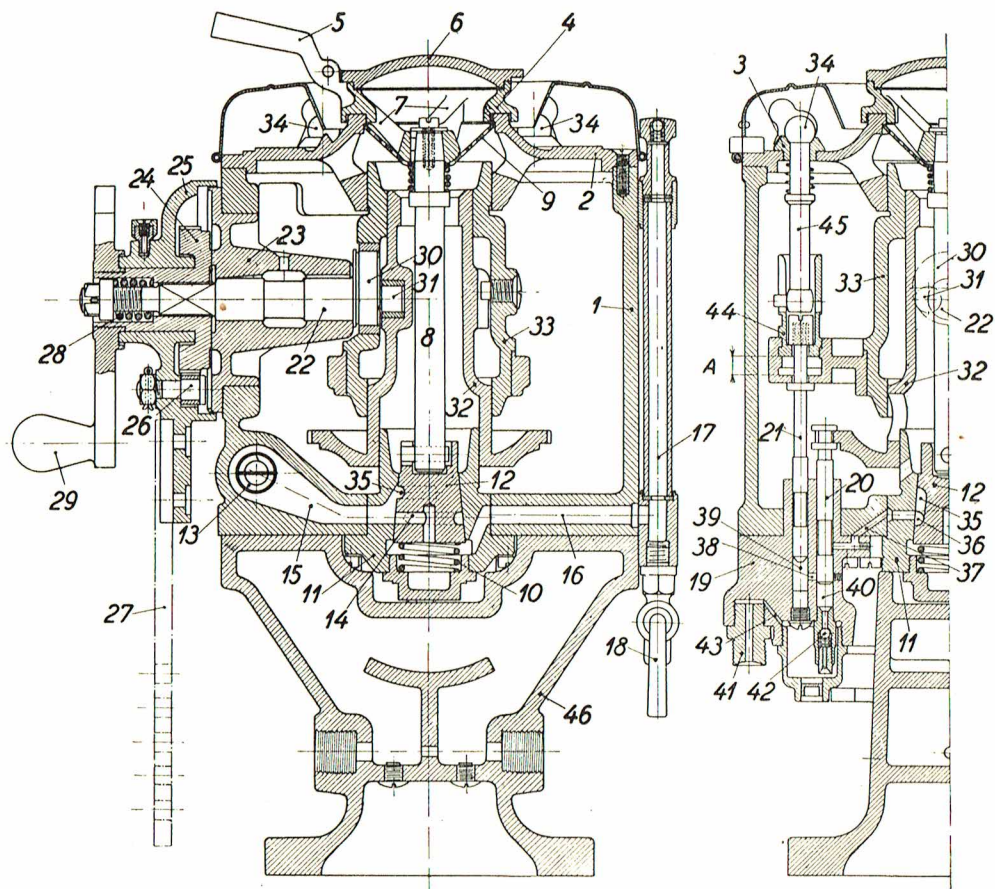

Fig. 225 1:4

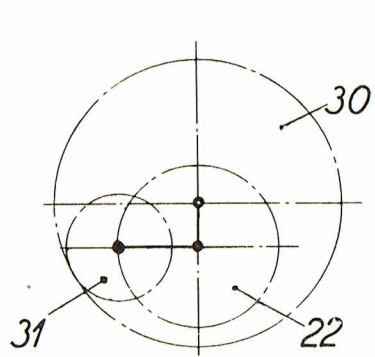

Fig. 225 a

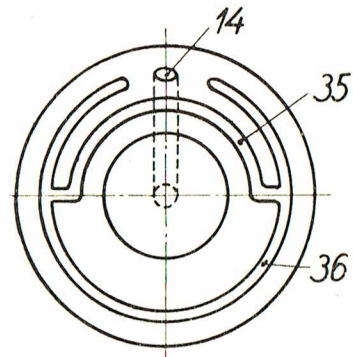

Fig. 225 b

Fig. 225—225 b

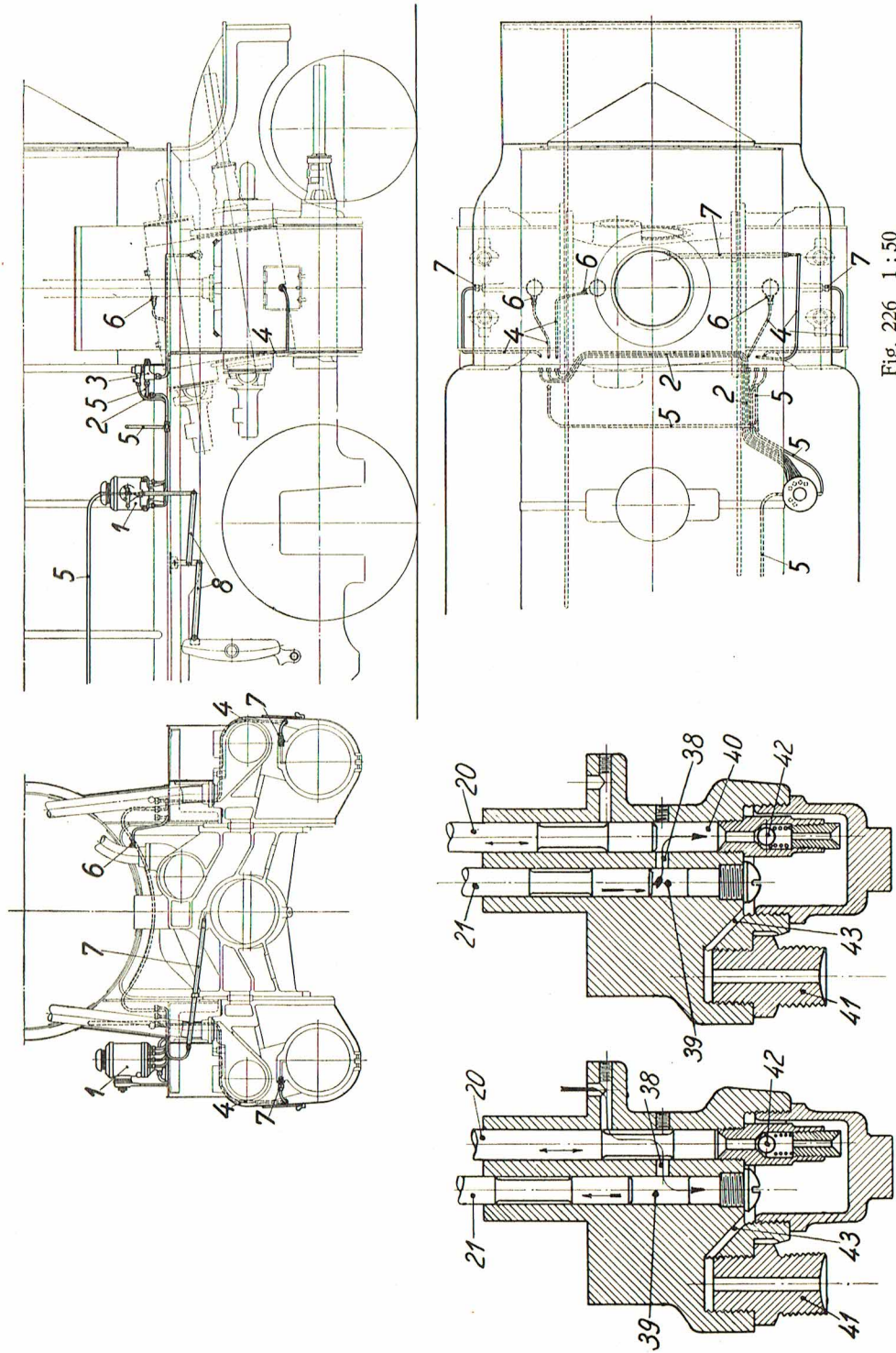

Fig. 226 1:50

Fig. 225 d 1:2

Fig. 225 c 1:2

Fig. 225 c—226



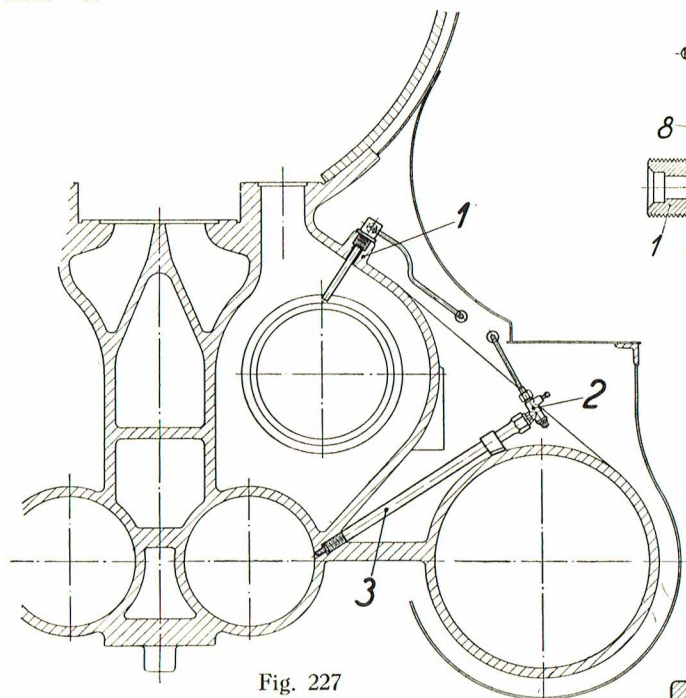

Fig. 227  
1:20

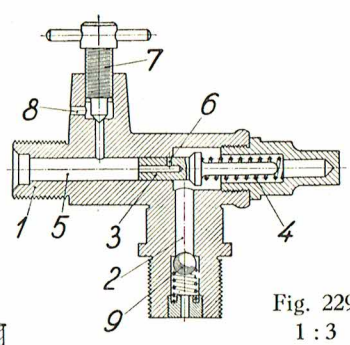

Fig. 229  
1:3

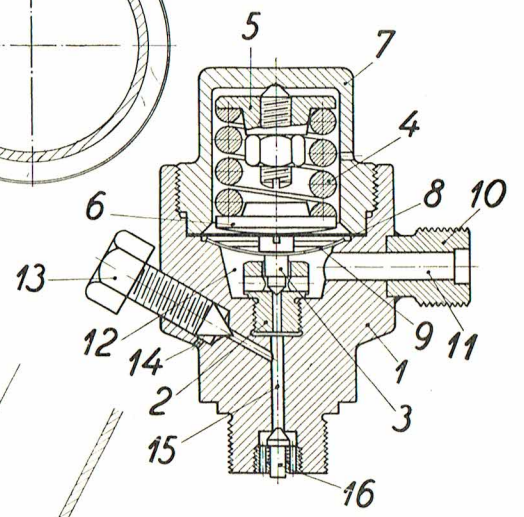

Fig. 230  
1:2

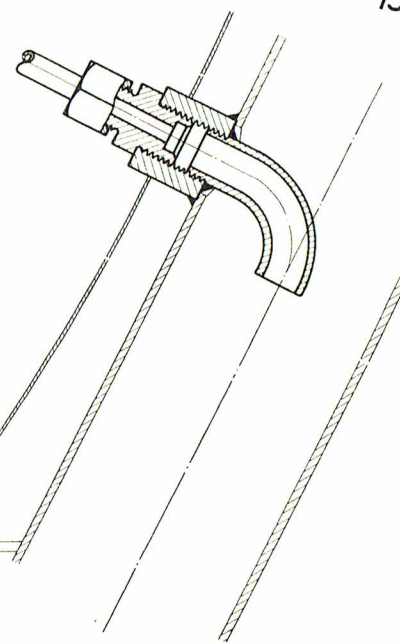

Fig. 228 1:4

Fig. 227—230

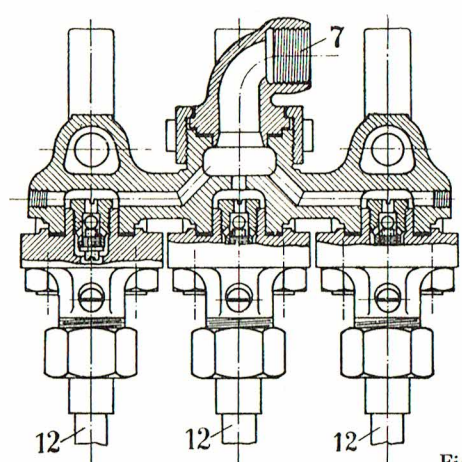

Fig. 231  
1:3

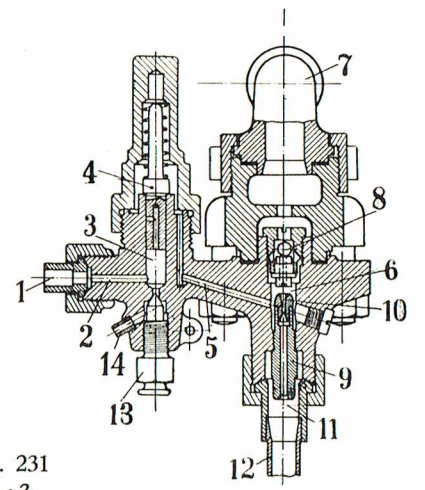

Fig. 232 1:3

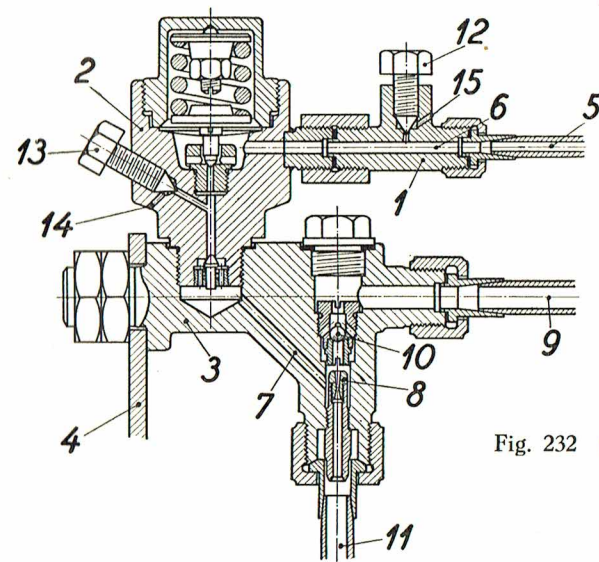

Fig. 233

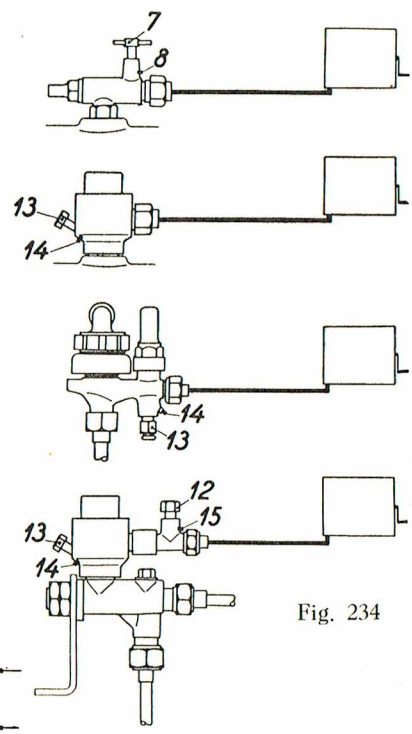
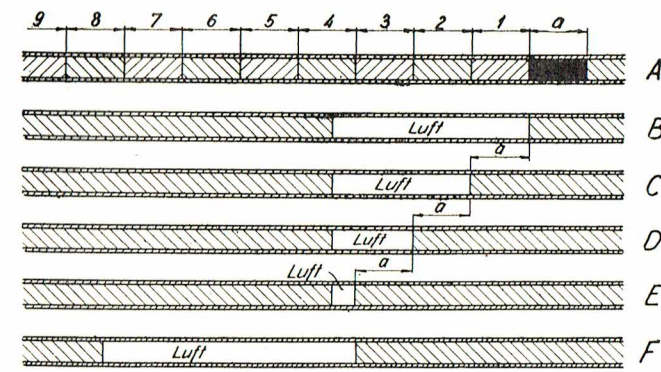

Fig. 234

Fig. 231—234



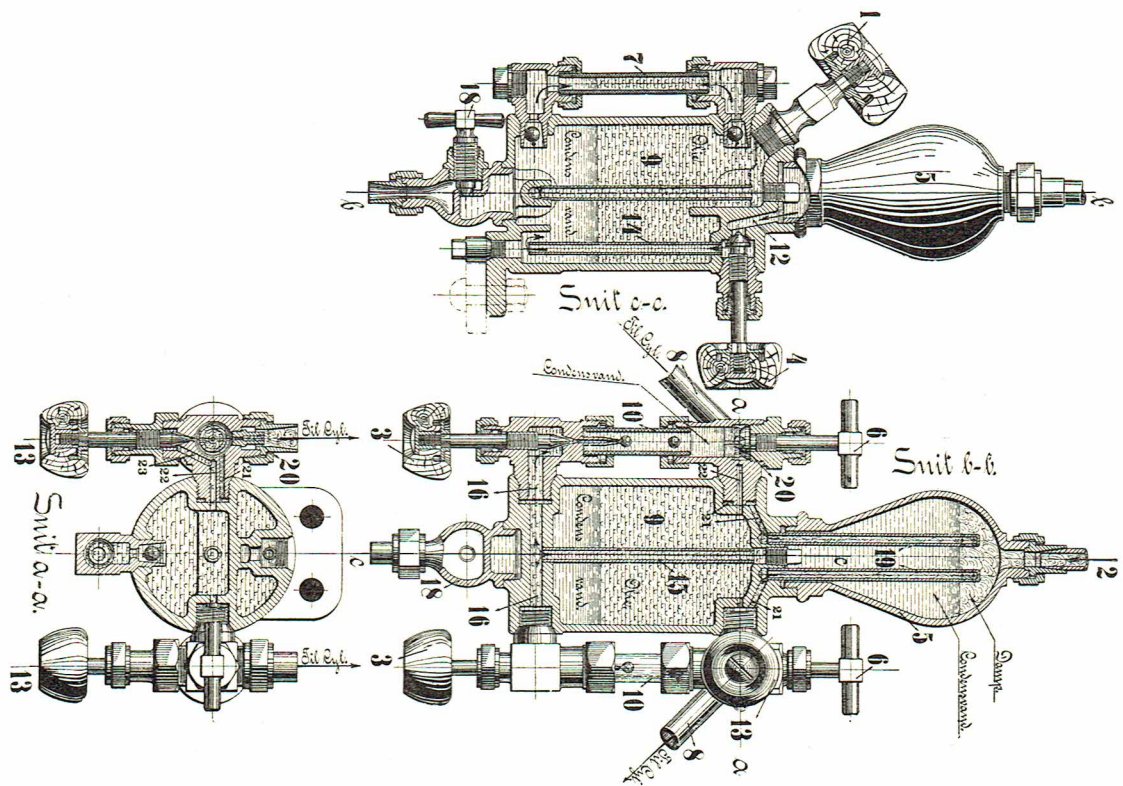

Fig. 235  
1:5

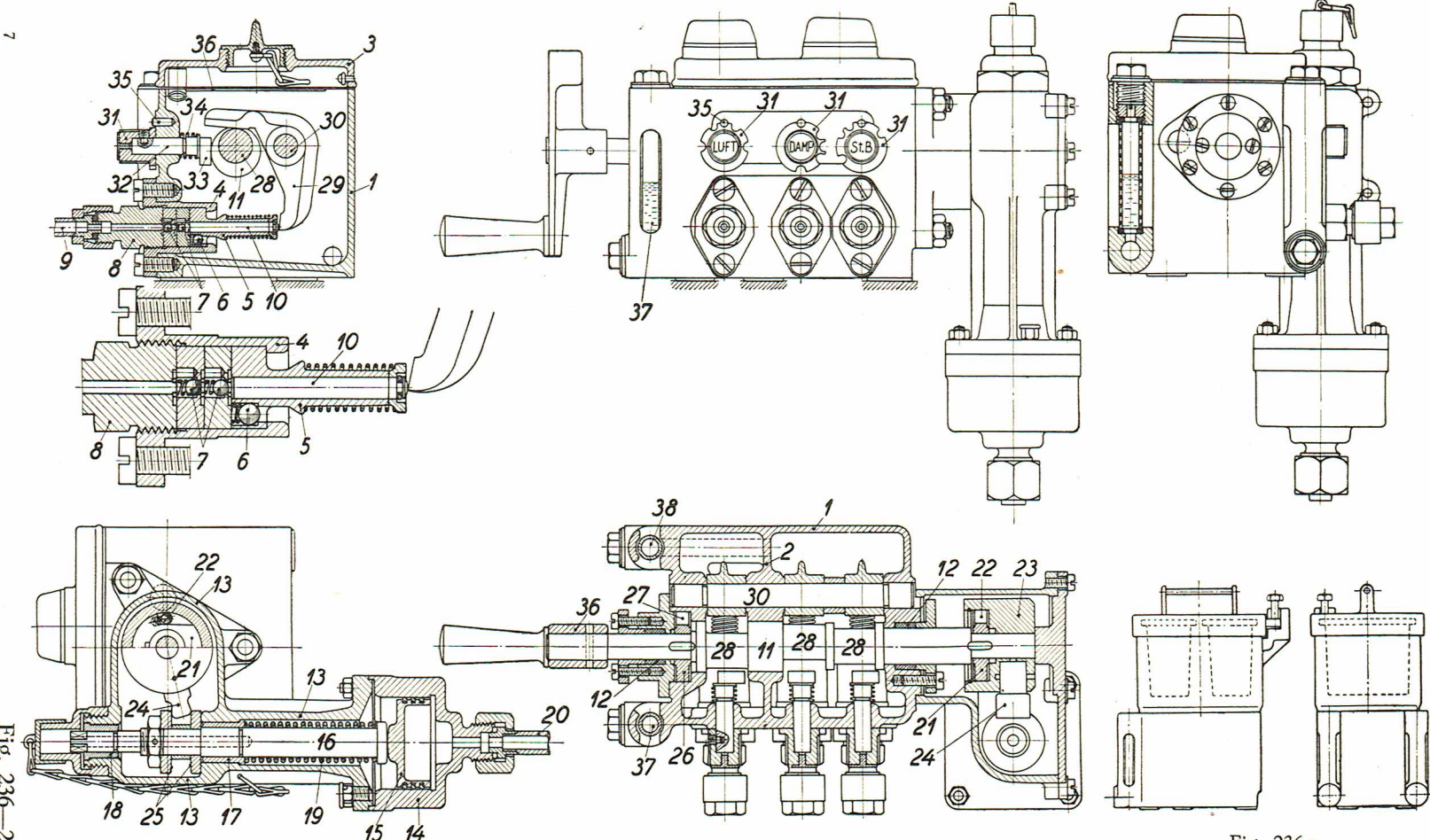

Fig. 236 1:4

Fig. 236 a  
1:8



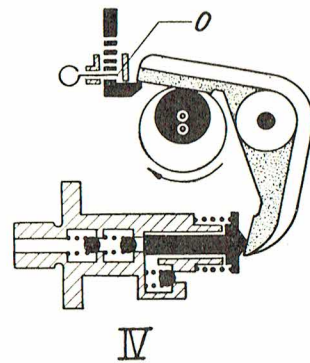
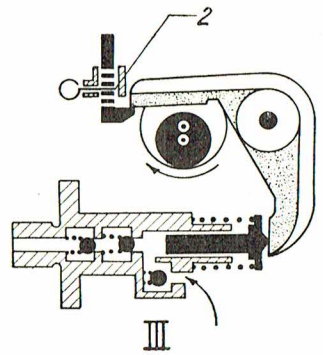
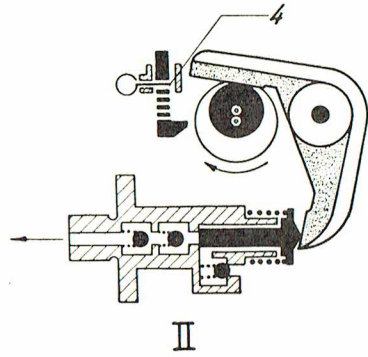
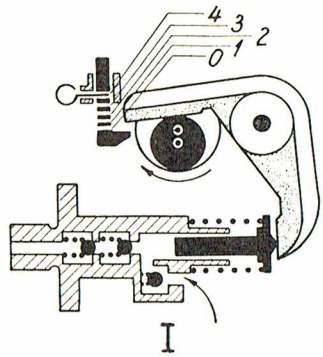

Fig. 237

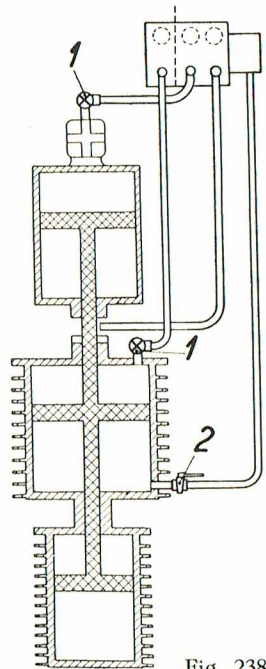

Fig. 238 a

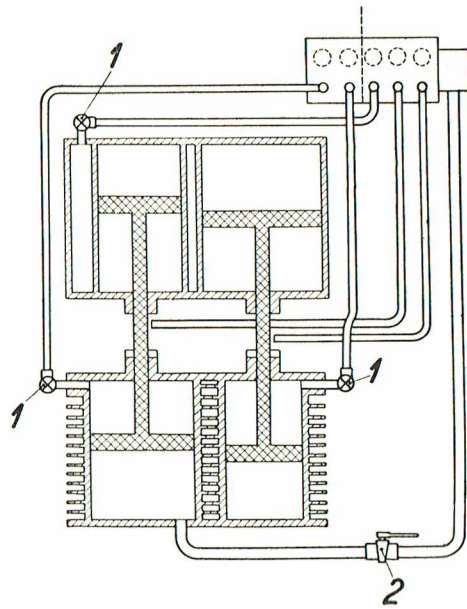

Fig. 238 b

Fig. 237—238 b

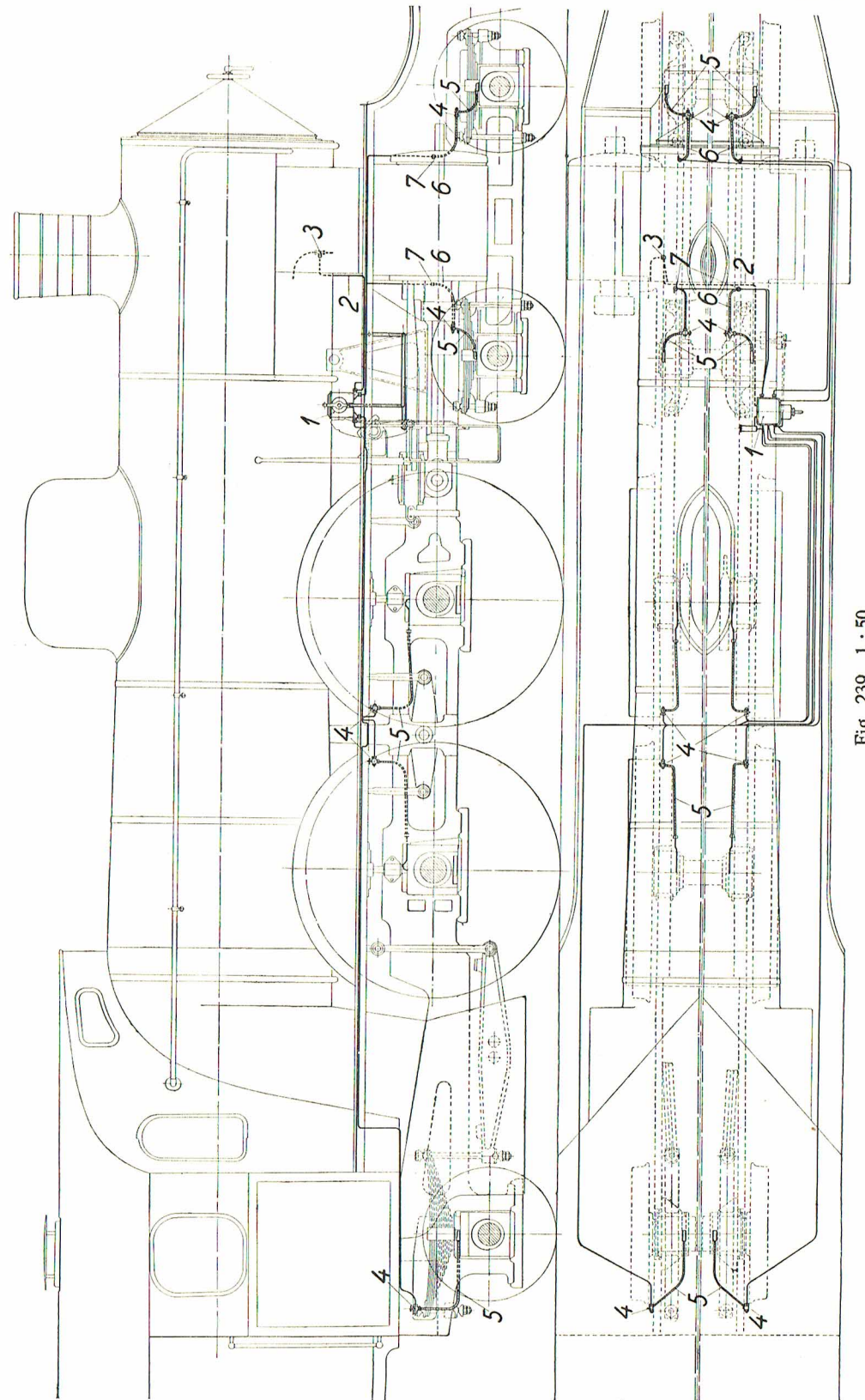

Fig. 239 1 : 50

Fig. 239



Fig. 240—243

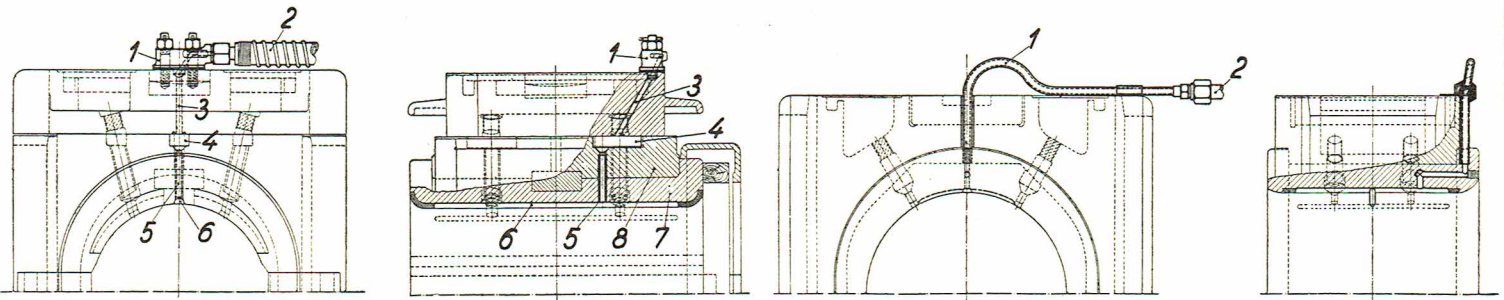

Fig. 240 1 : 7,5

Fig. 241 1 : 7,5

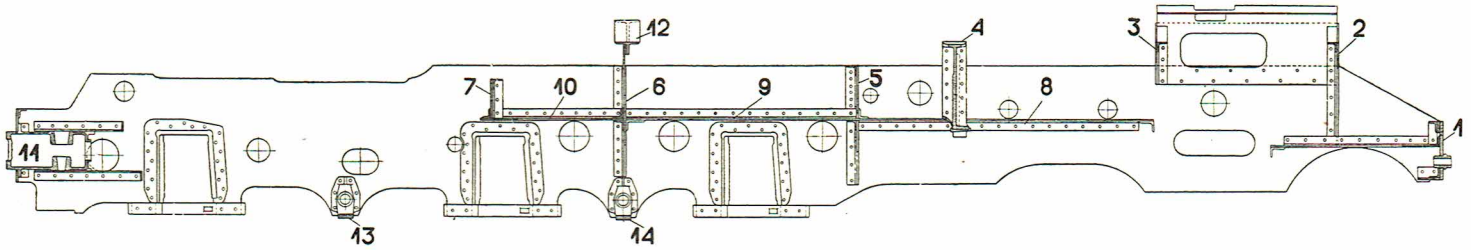

Fig. 242 1 : 60

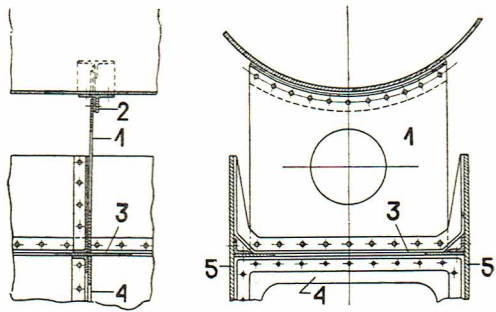

Fig. 243 1 : 40

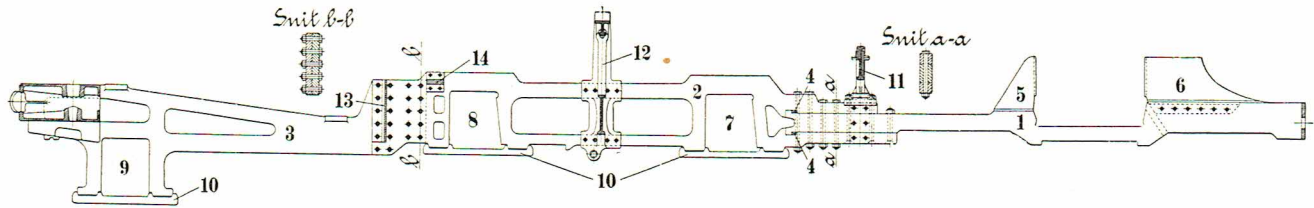

Fig. 244 1 : 60

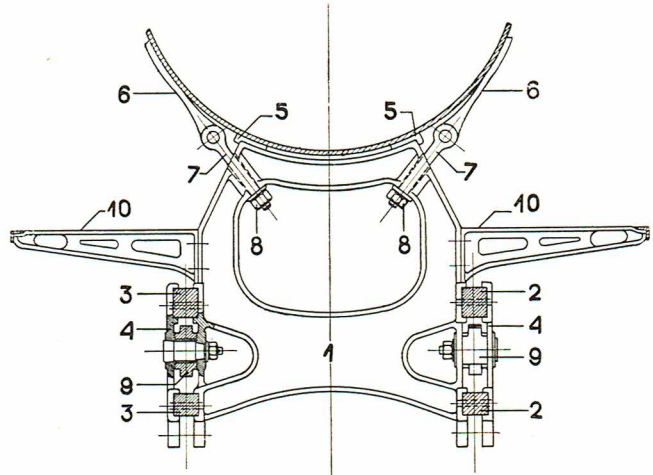

Fig. 245 1 : 30

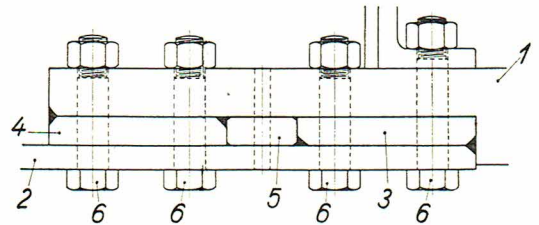

Fig. 246 1 : 7,5

Fig. 244—246

PLAN 97

Fig. 247—247 e



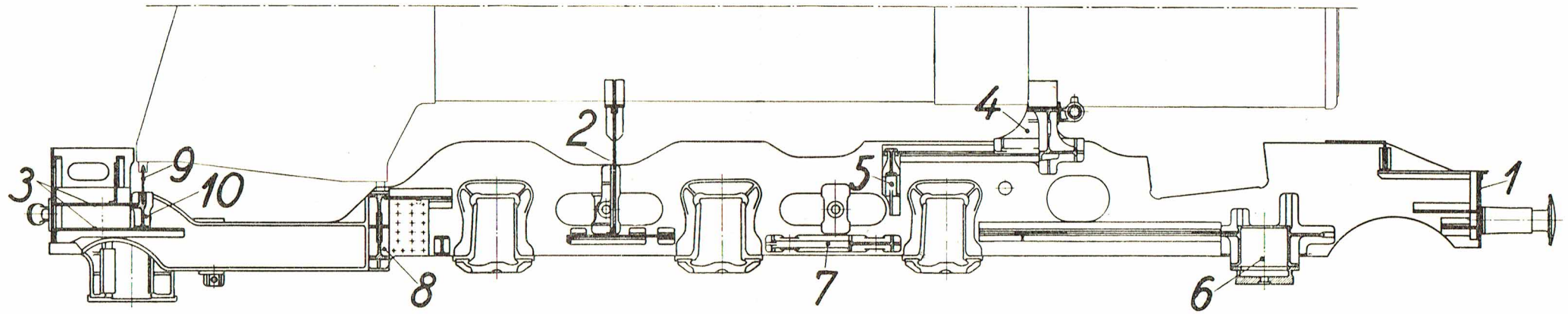

Fig. 247 1:50

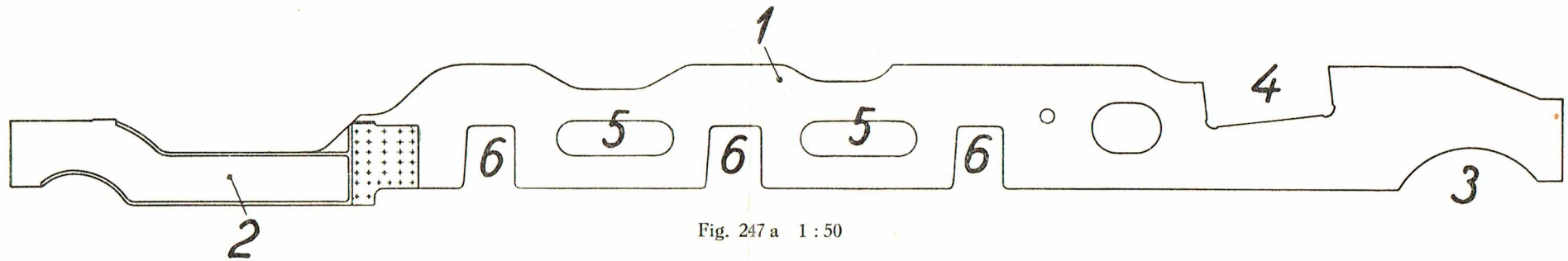

Fig. 247 a 1:50

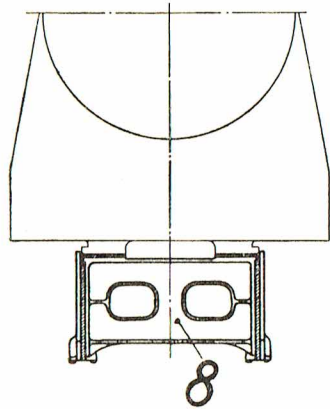

Fig. 247 b 1:50

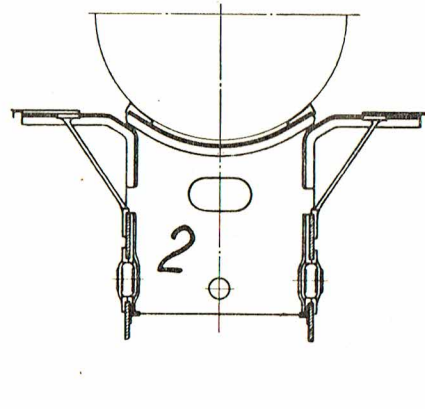

Fig. 247 c 1:50

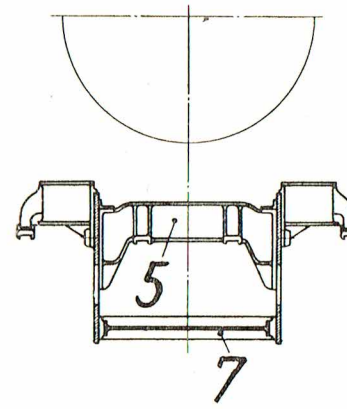

Fig. 247 d 1:50

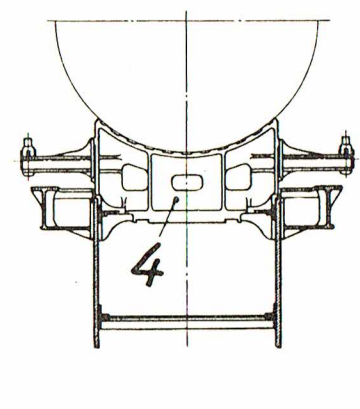

Fig. 247 e 1:50

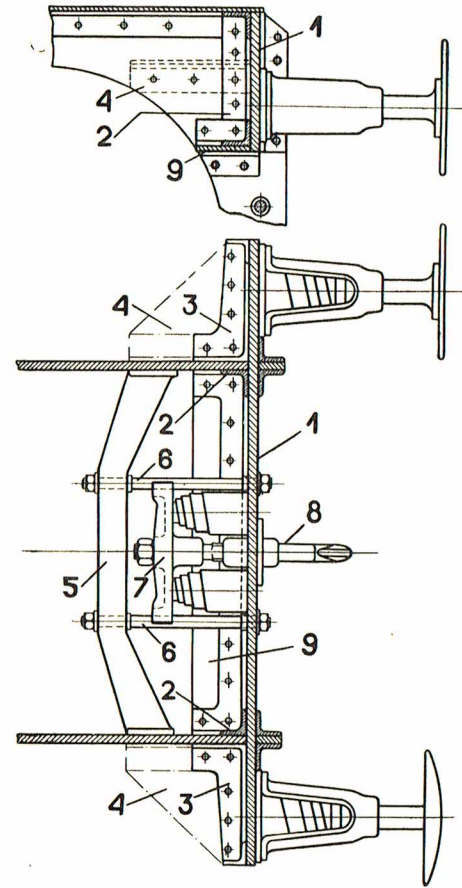

Fig. 248  
1 : 25

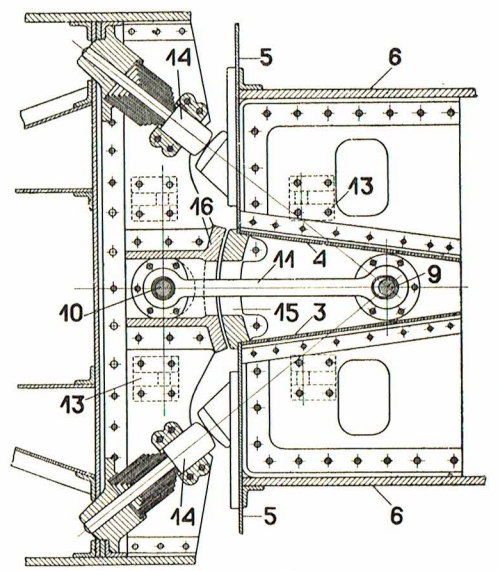
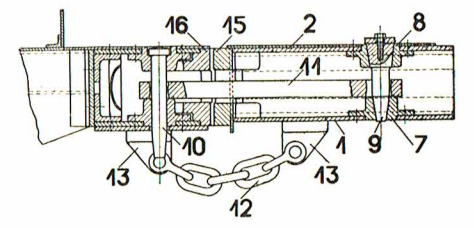

Fig. 249  
1 : 25

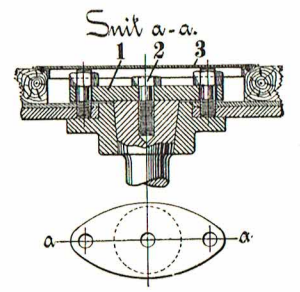

Fig. 250  
1 : 10



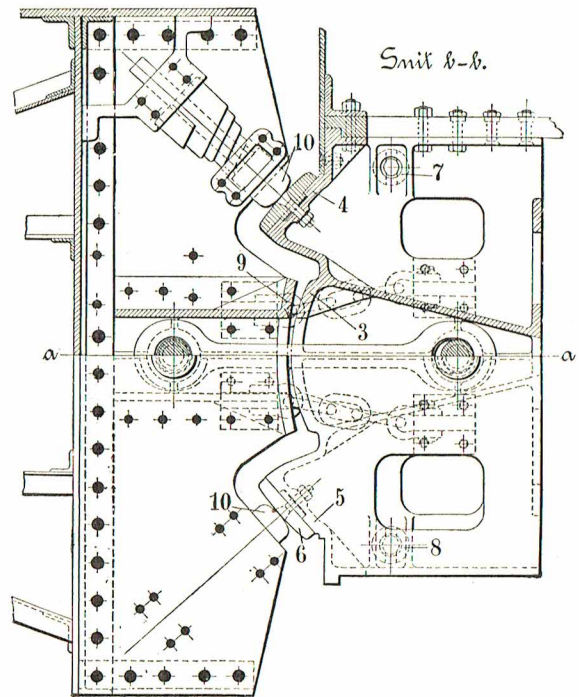
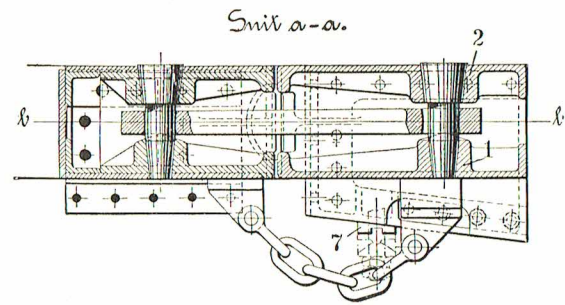

Fig. 251 1 : 20

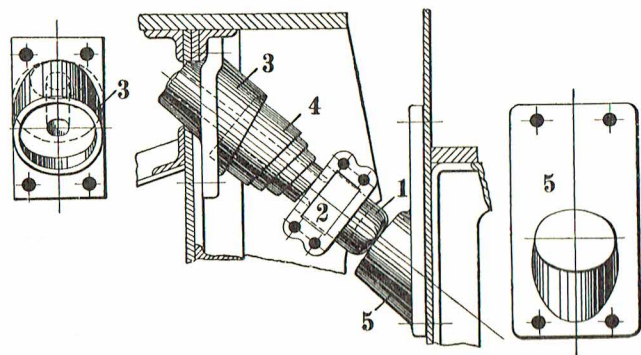

Fig. 252 1 : 15

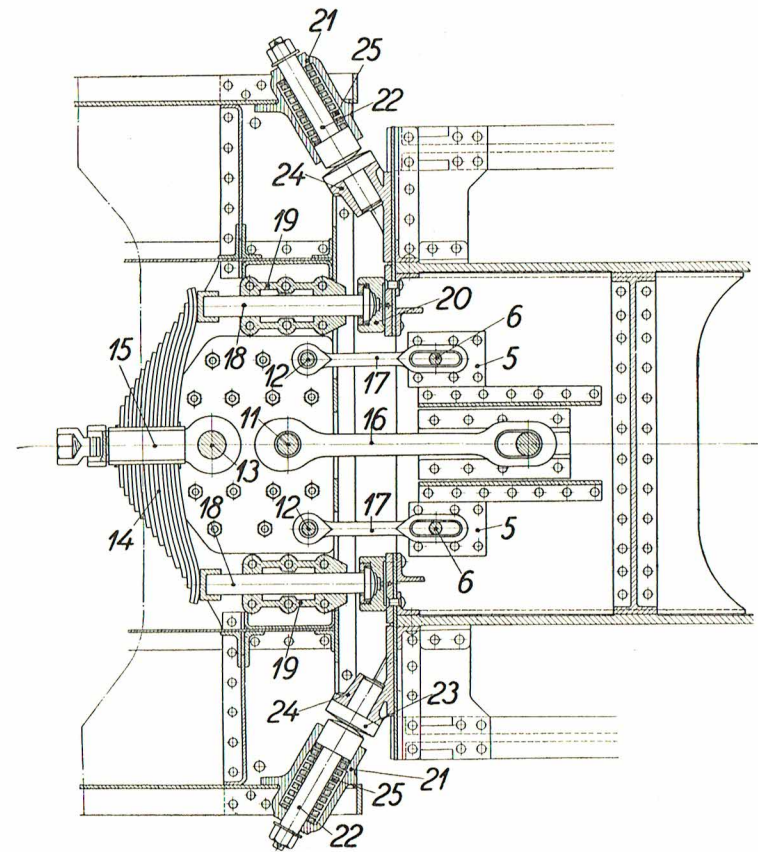
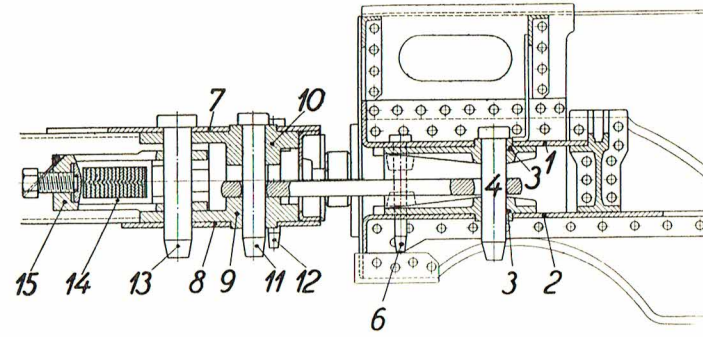

Fig. 253 1 : 25

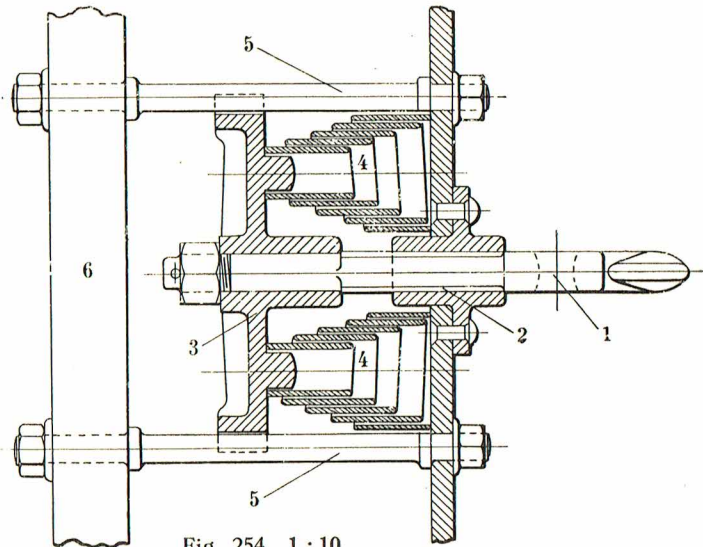

Fig. 254 1:10

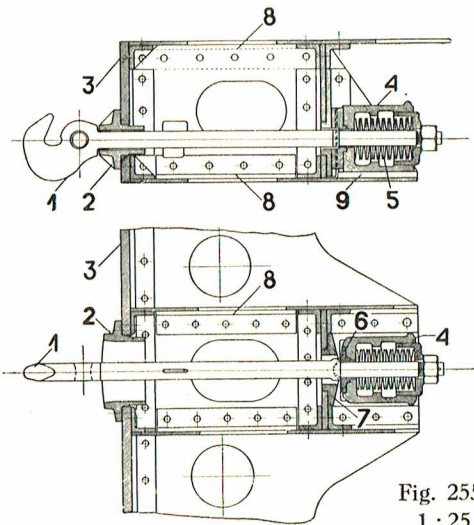

Fig. 255 1:25

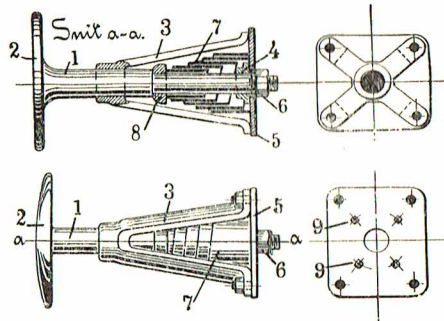

Fig. 256 1:20

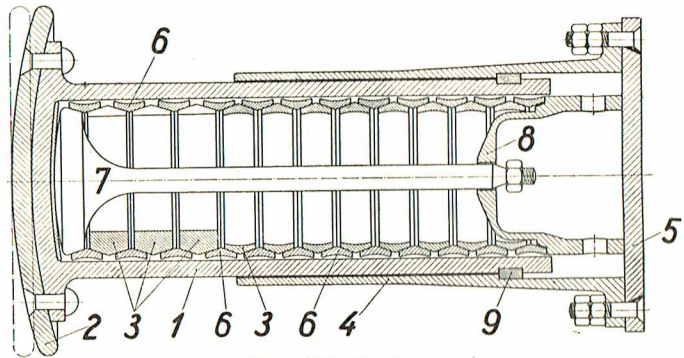

Fig. 257 1:8

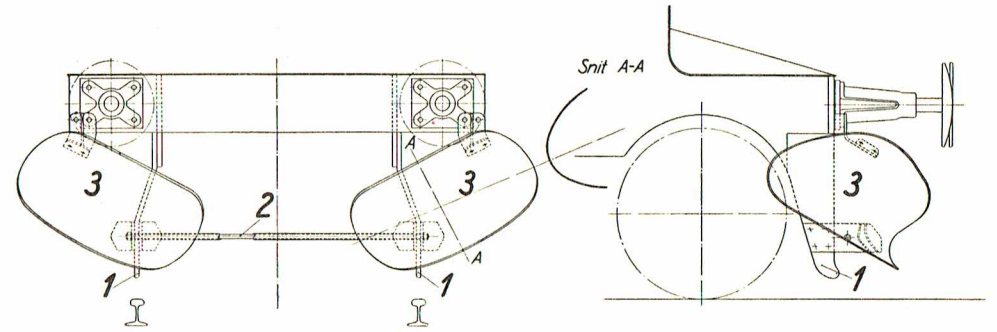

Fig. 258 1:40

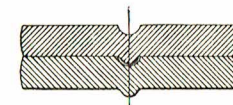

Fig. 259 1:3

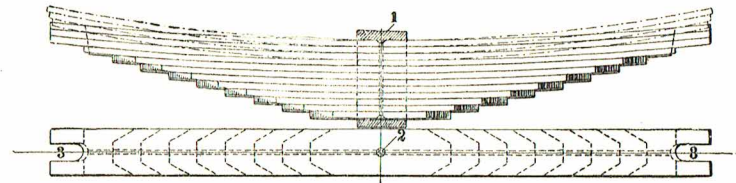

Fig. 260 1:15

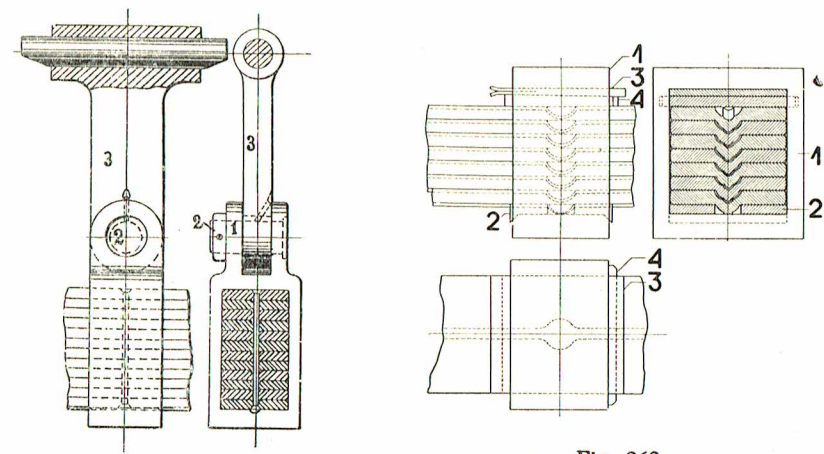

Fig. 261 1:10

Fig. 262 1:7



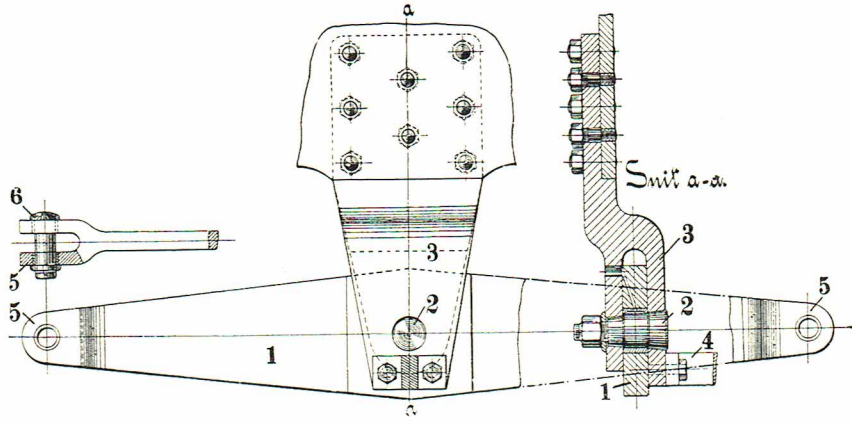

Fig. 265 1 : 15

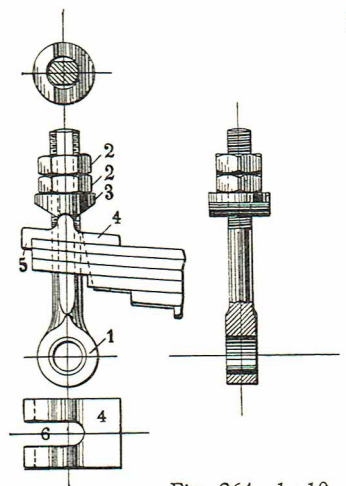
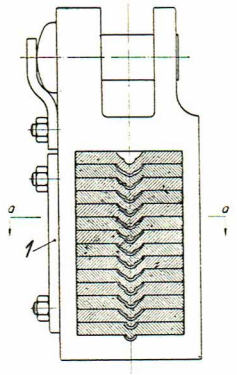

Fig. 263 1 : 7,5

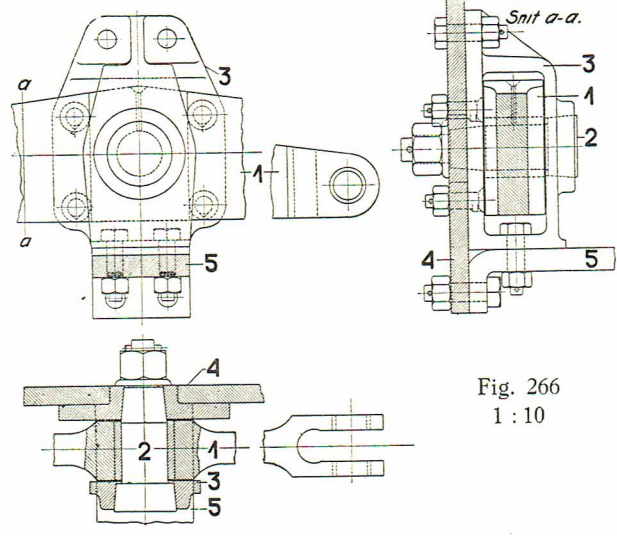

Fig. 266 1 : 10

Fig. 264 1 : 10

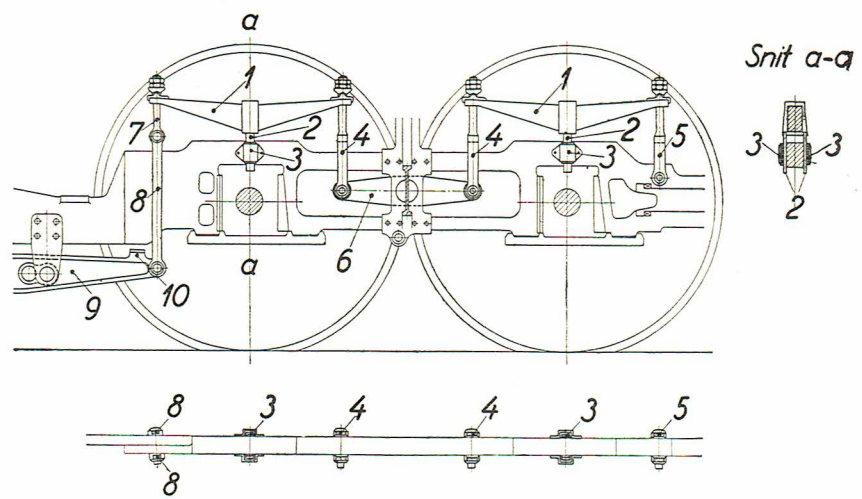

Fig. 267 1 : 50

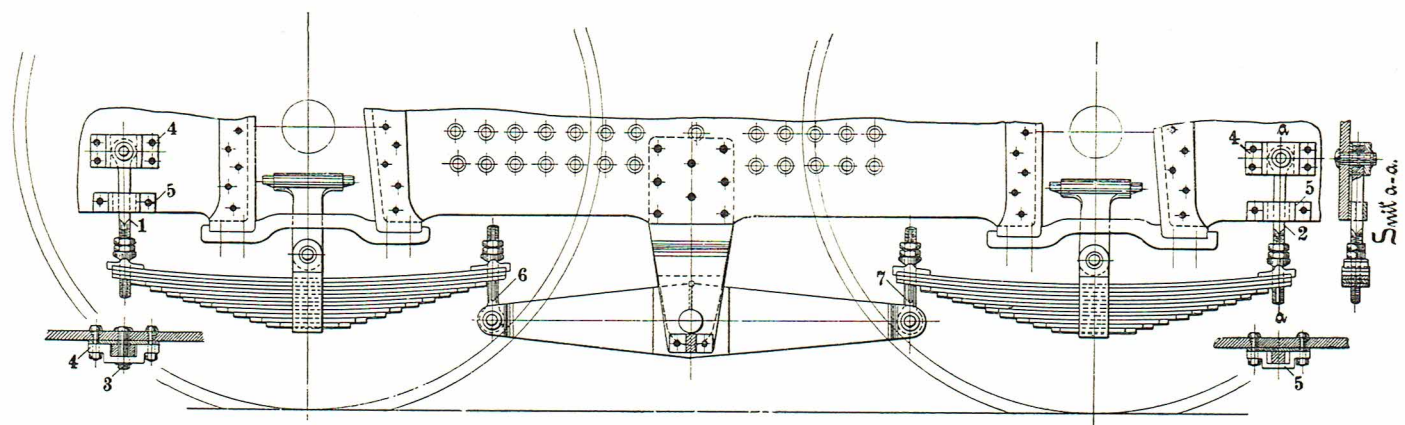

Fig. 268 1 : 25

*Snit A-A*

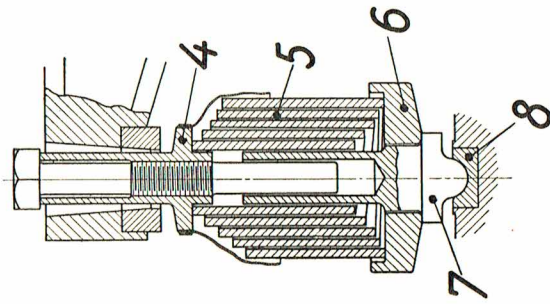

Fig. 269 a  
1 : 7,5

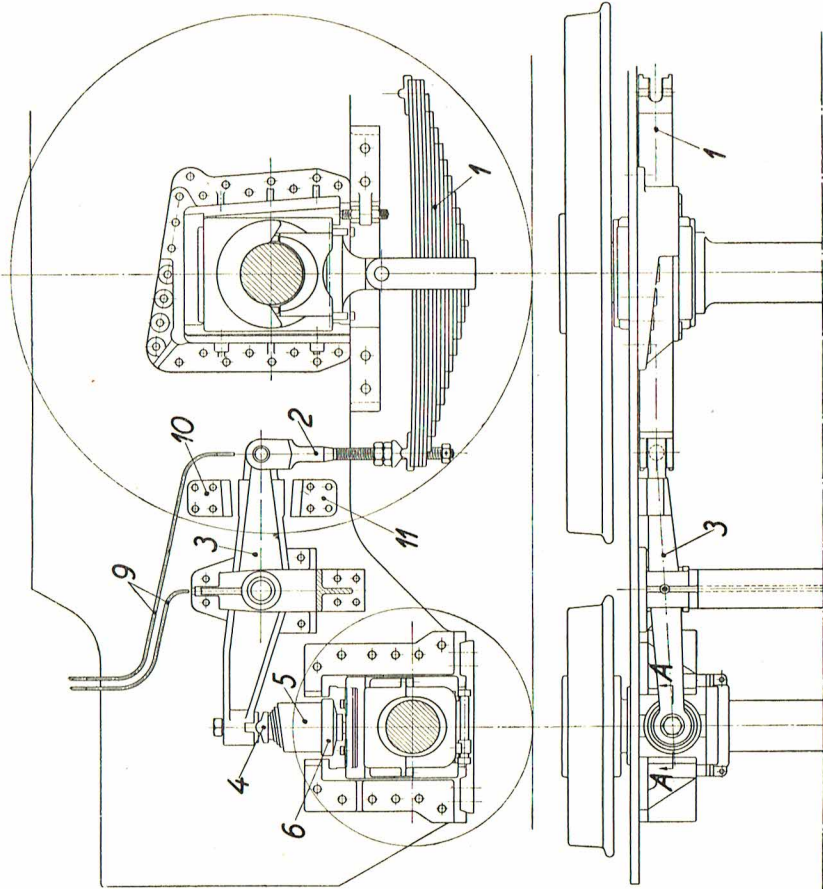

Fig. 269  
1 : 25

Fig. 269—269 a

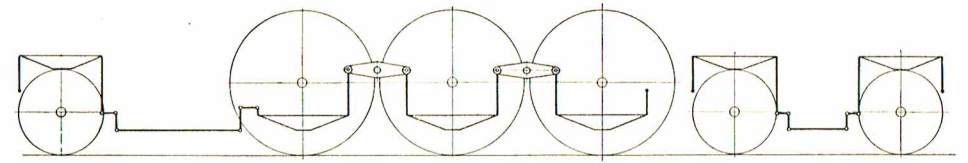

Fig. 270

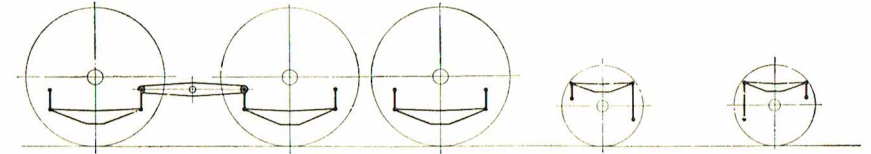

Fig. 271

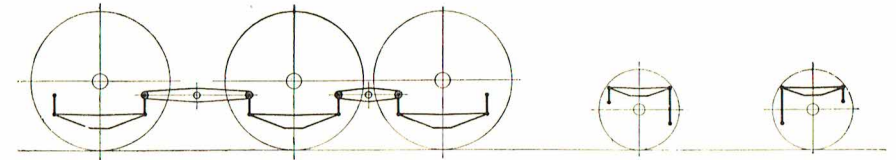

Fig. 272

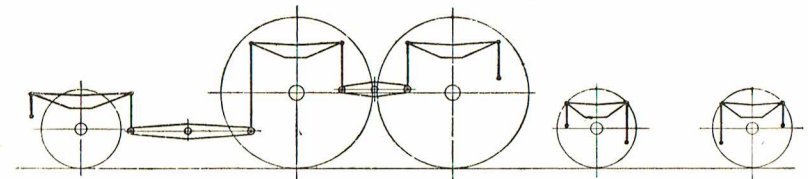

Fig. 273

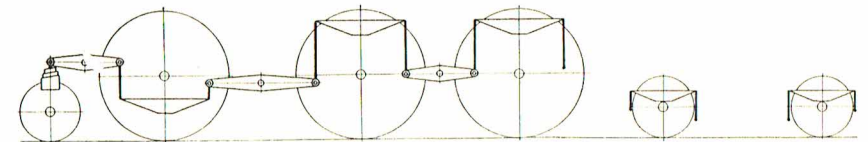

Fig. 274

Fig. 270—274



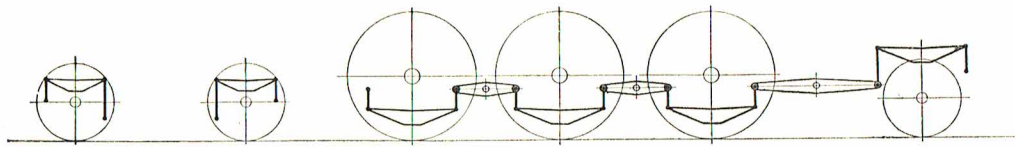

Fig. 275

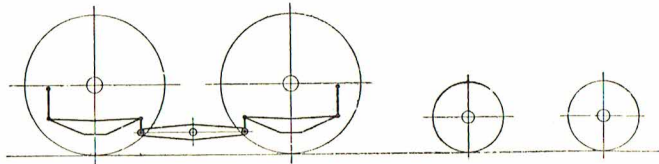

Fig. 276

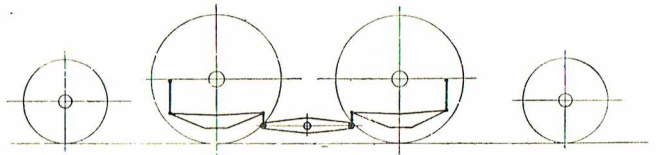

Fig. 277

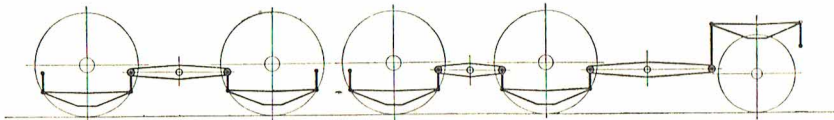

Fig. 278

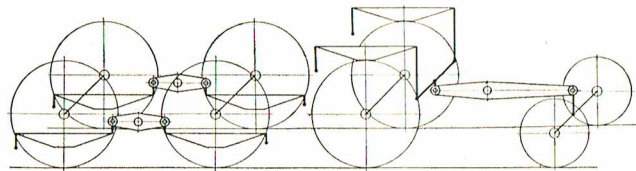

Fig. 279

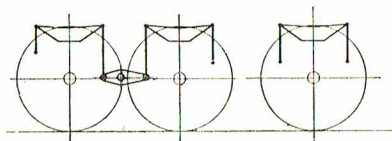

Fig. 280

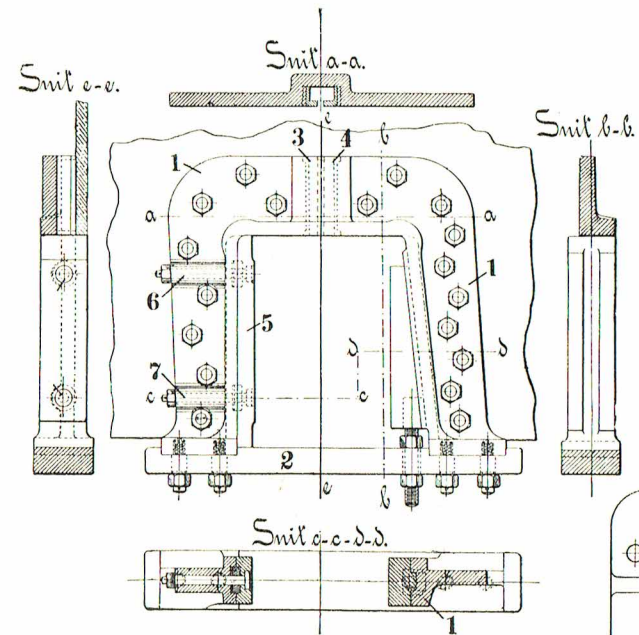

Fig. 281  
1 : 15

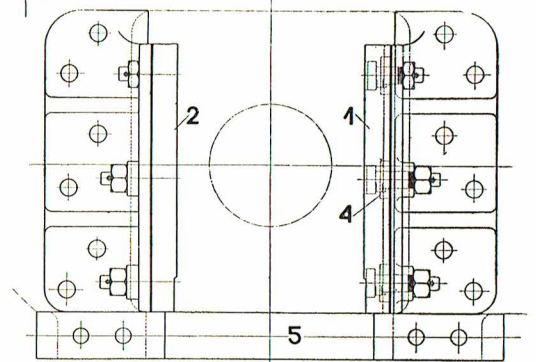

Fig. 283  
1 : 10

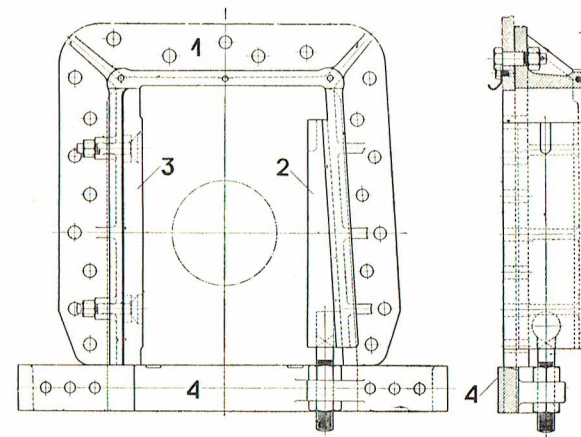
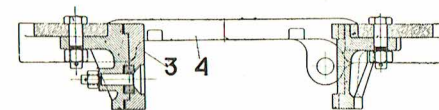

Fig. 282  
1 : 15





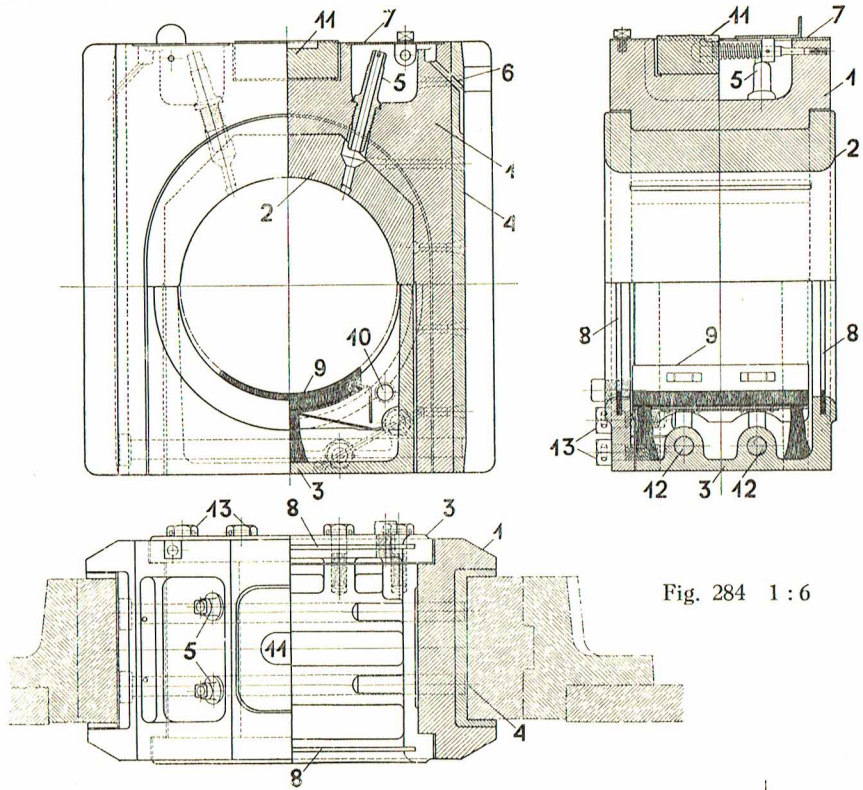

Fig. 284 1:6

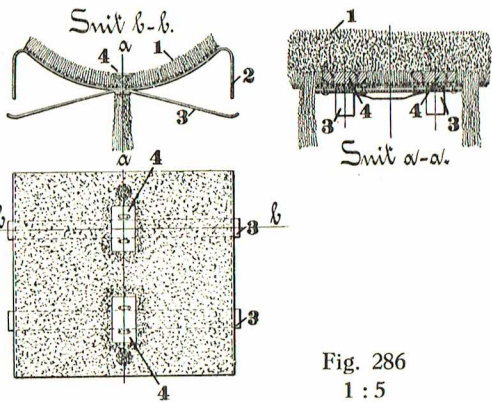

Fig. 285 1:3

Fig. 286 1:5

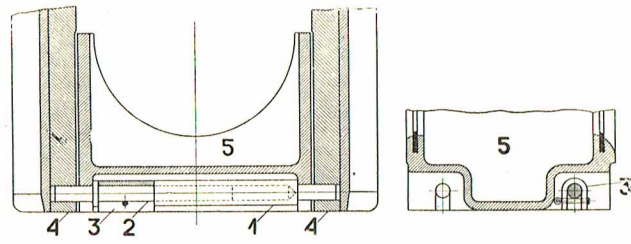

Fig. 287 1:8

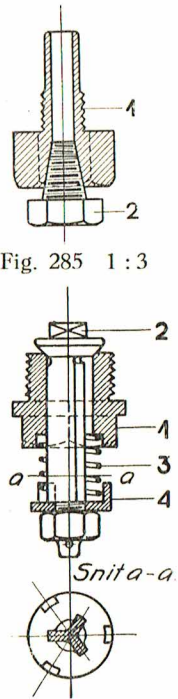

Fig. 288 1:2

Fig. 284—288

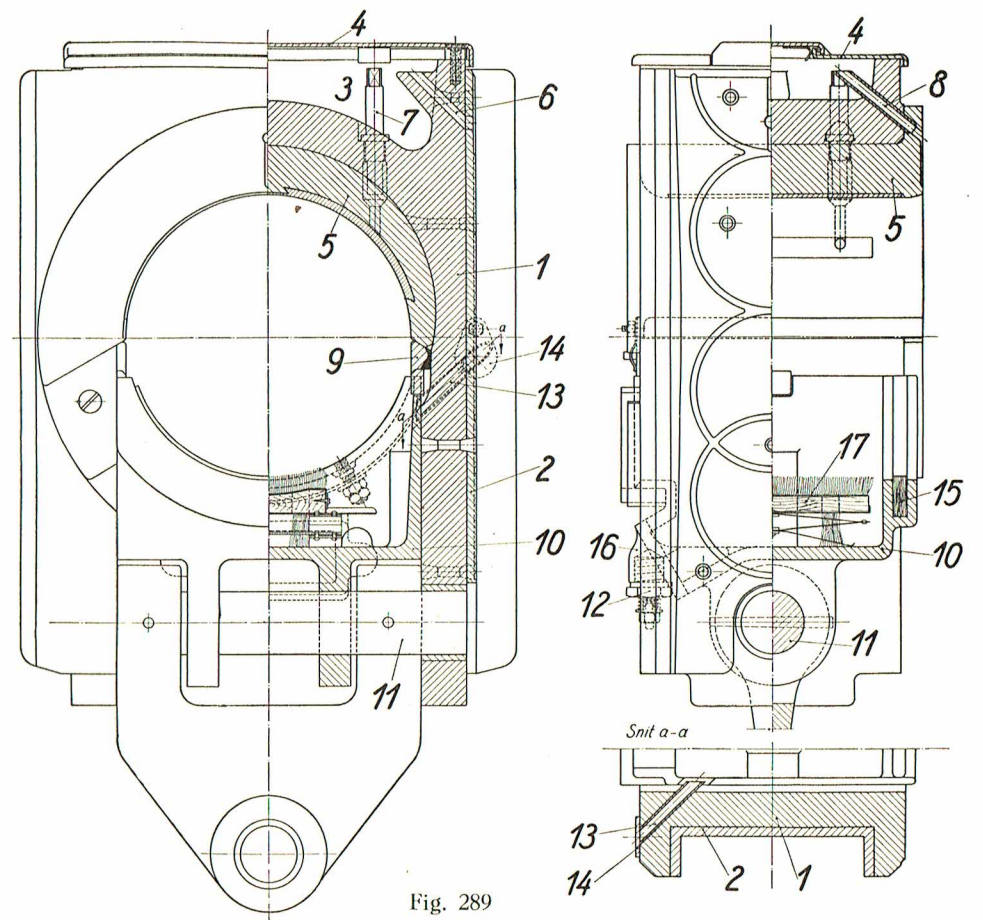

Fig. 289 1:6

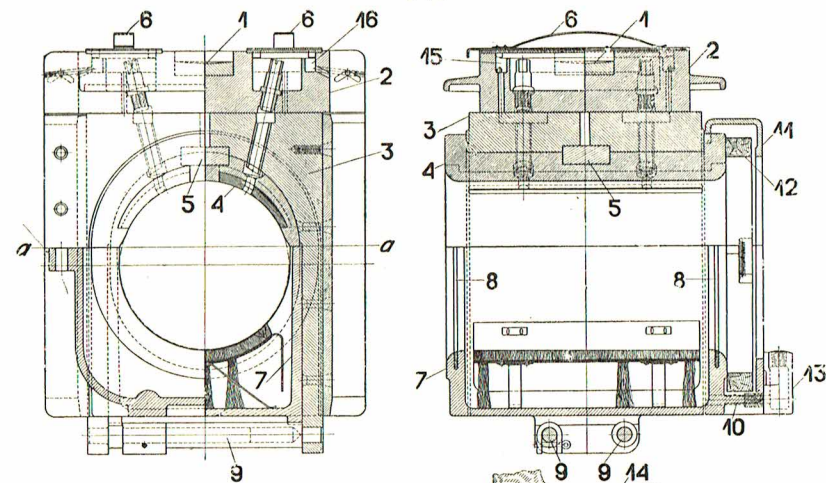

Fig. 290 1:8

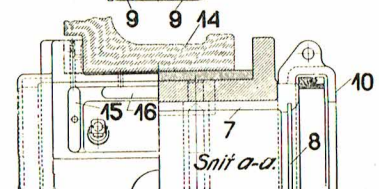

Fig. 289—290



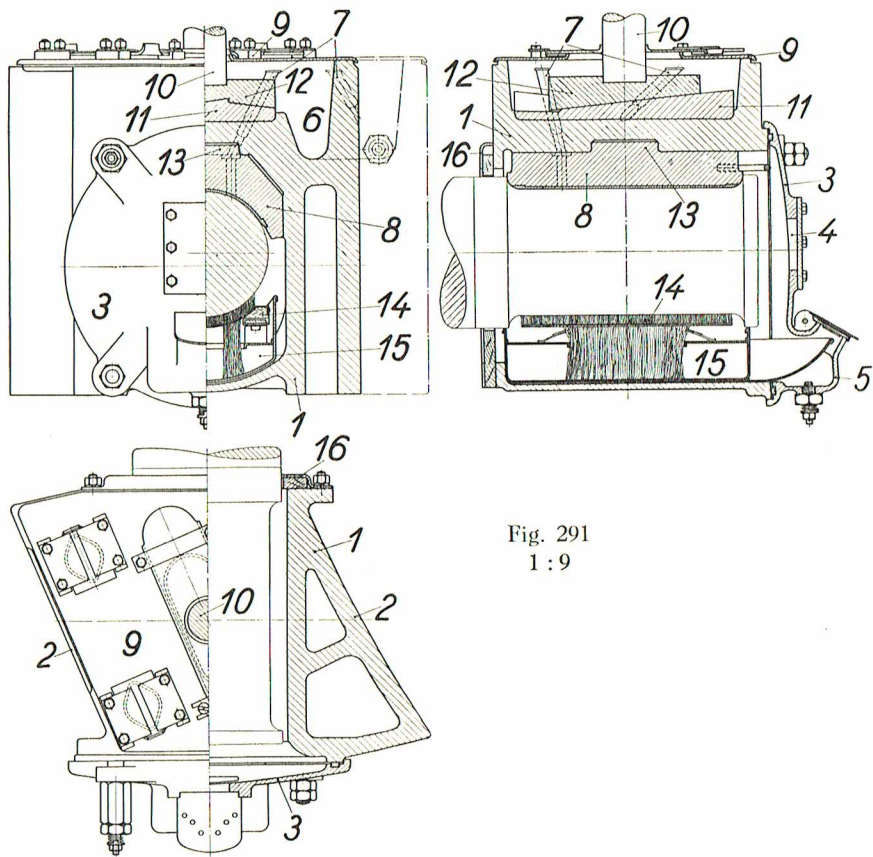

Fig. 291  
1:9

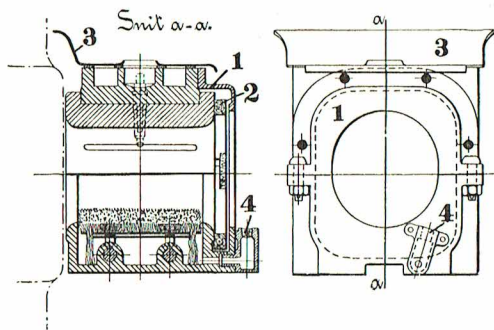

Fig. 292  
1:10

Fig. 291—292

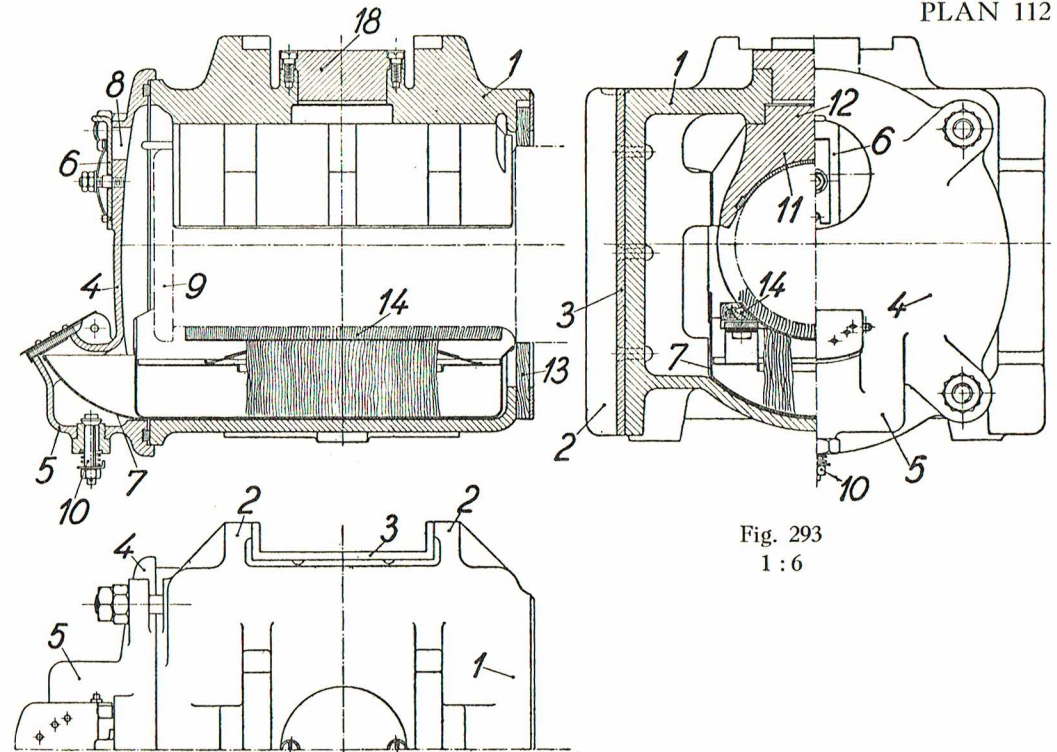

Fig. 293  
1:6

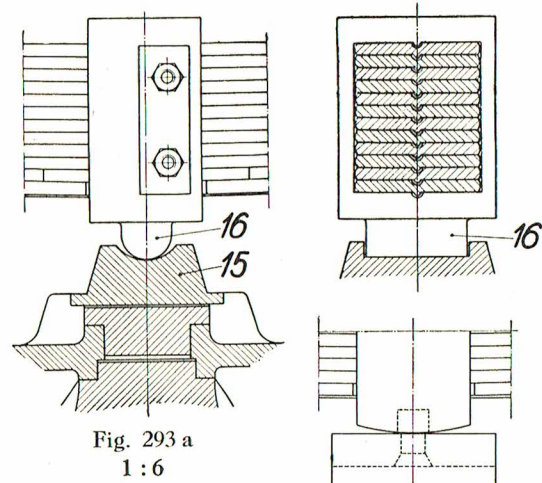

Fig. 293 a  
1:6

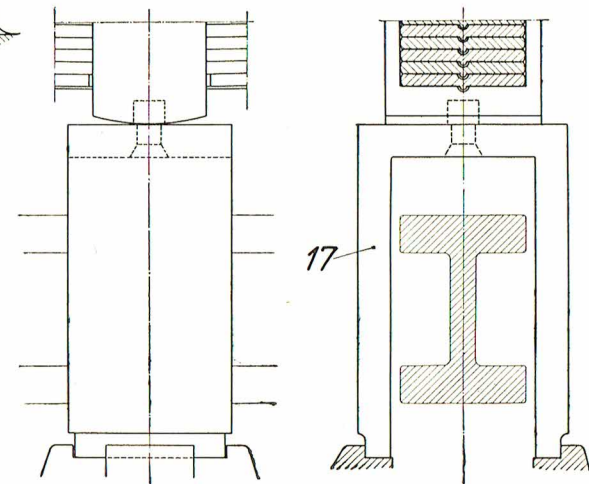

Fig. 293 b  
1:6

Fig. 293—293 b

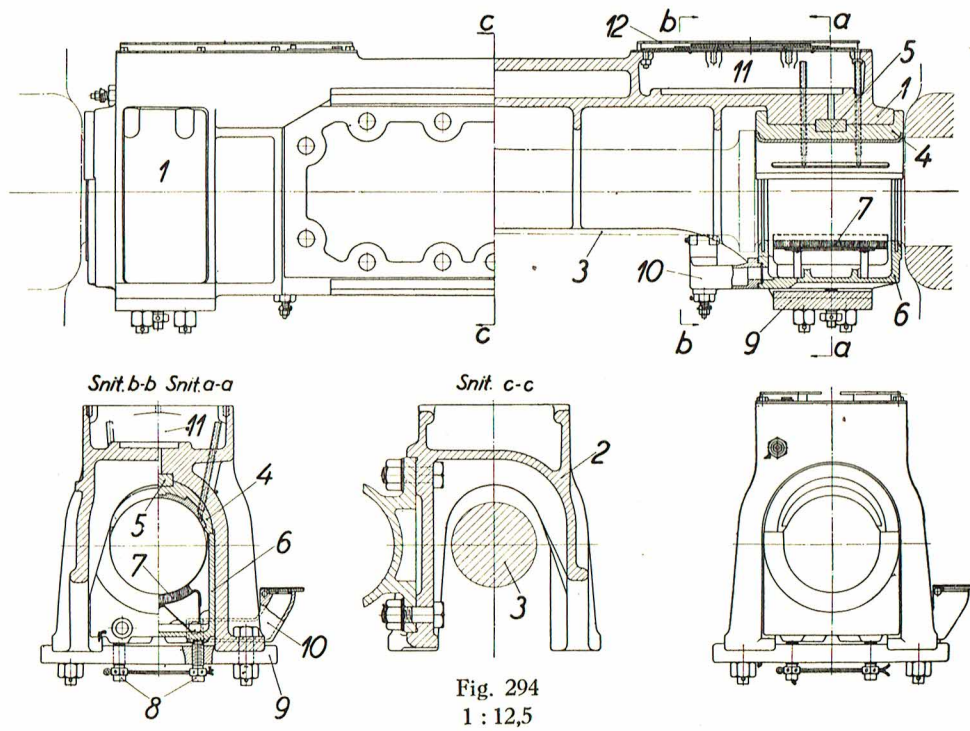

Fig. 294  
1 : 12,5

Fig. 294

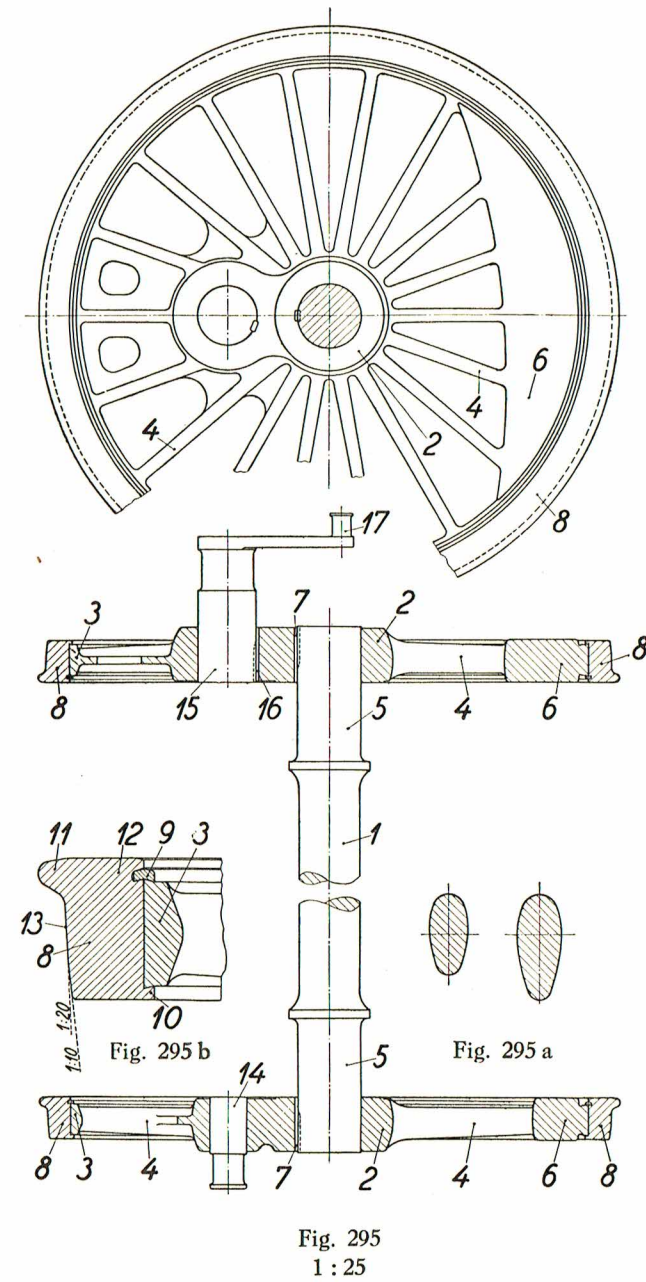

Fig. 295  
1 : 25

Fig. 295



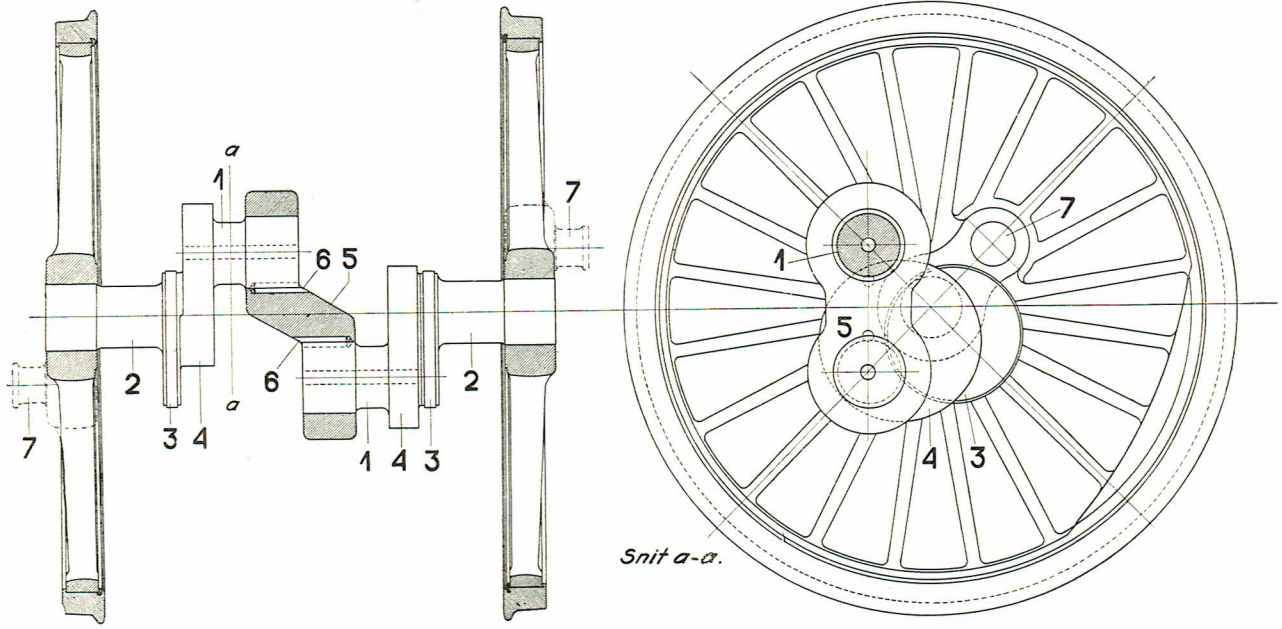

Fig. 296  
1 : 25

Fig. 296

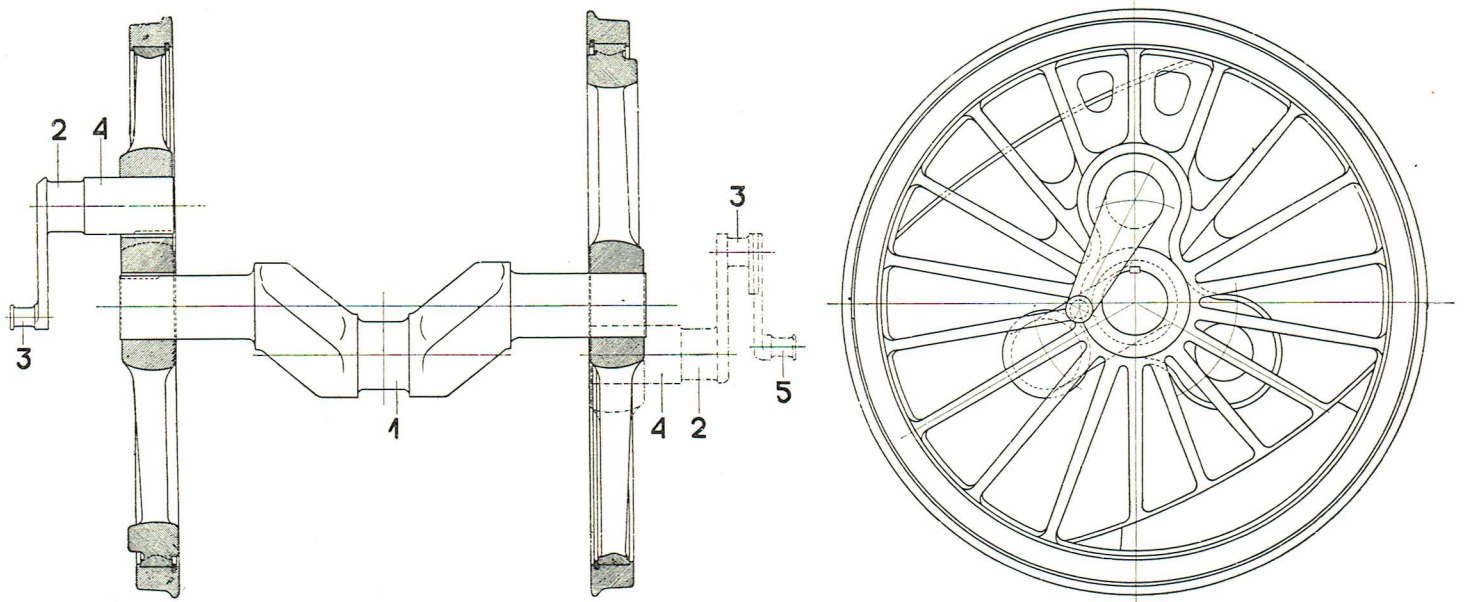

Fig. 297  
1 : 25

Fig. 297

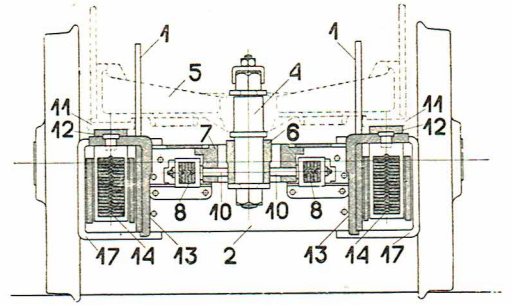

Fig. 298

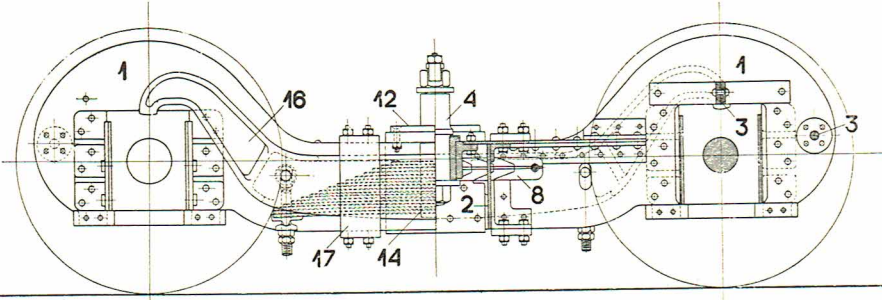

Fig. 298  
1:30

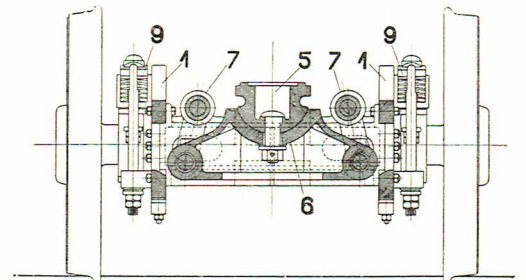
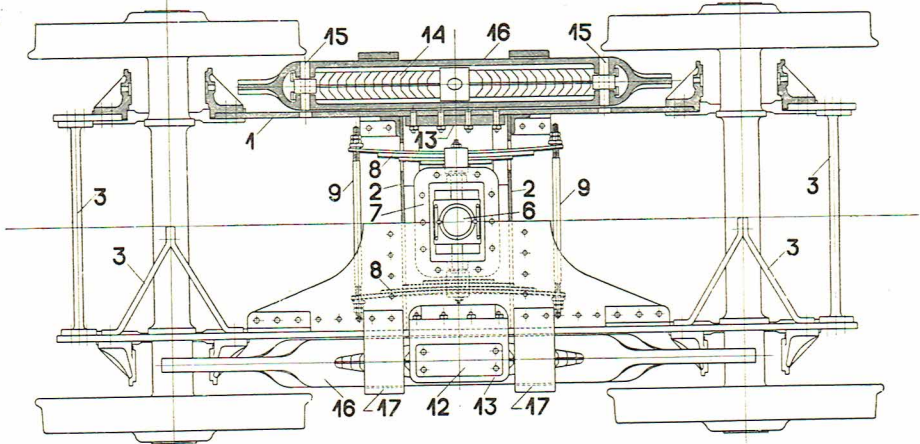

Fig. 299  
1:30

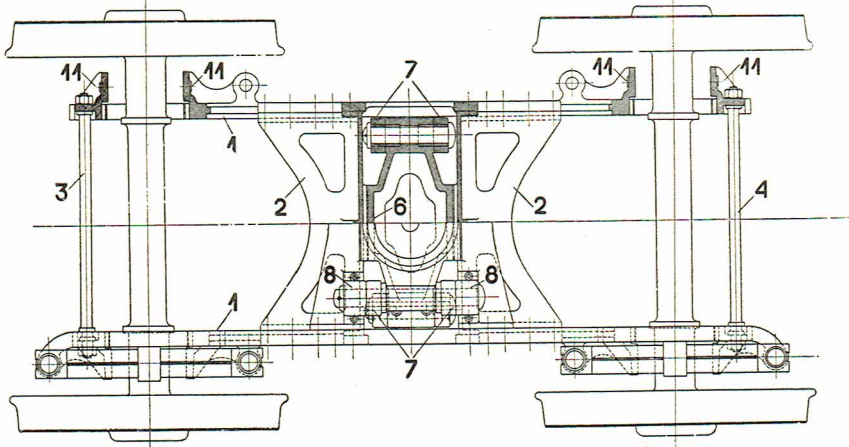
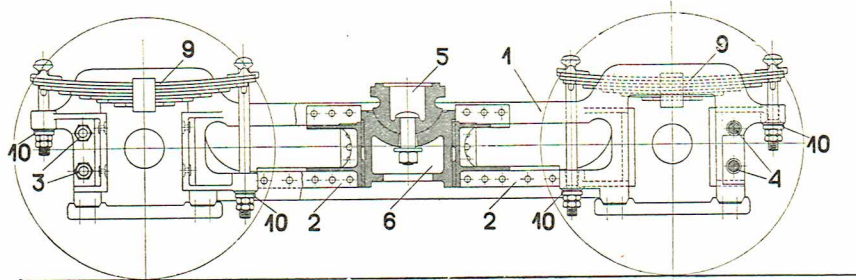

Fig. 299



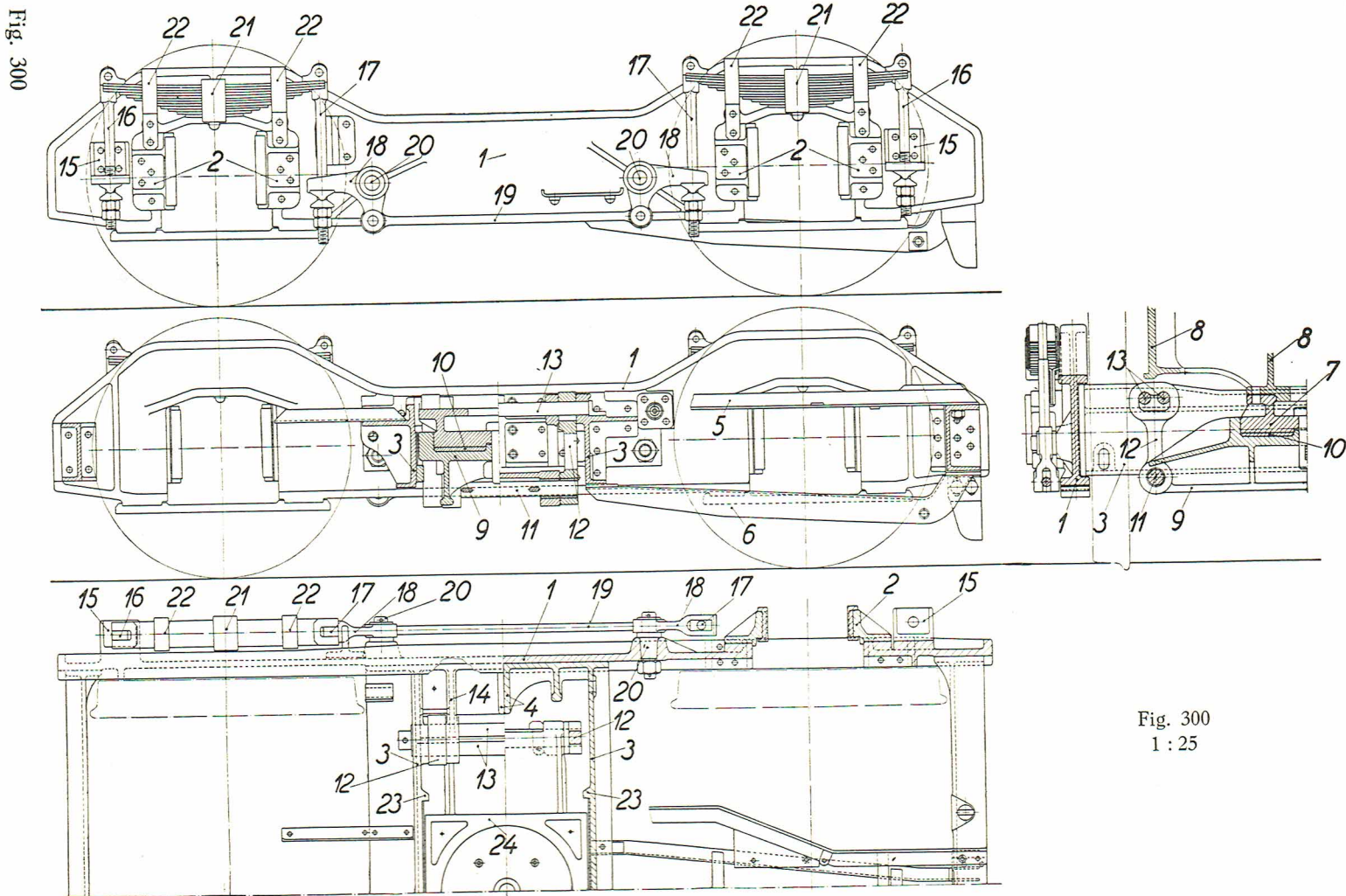

Fig. 300  
1:25

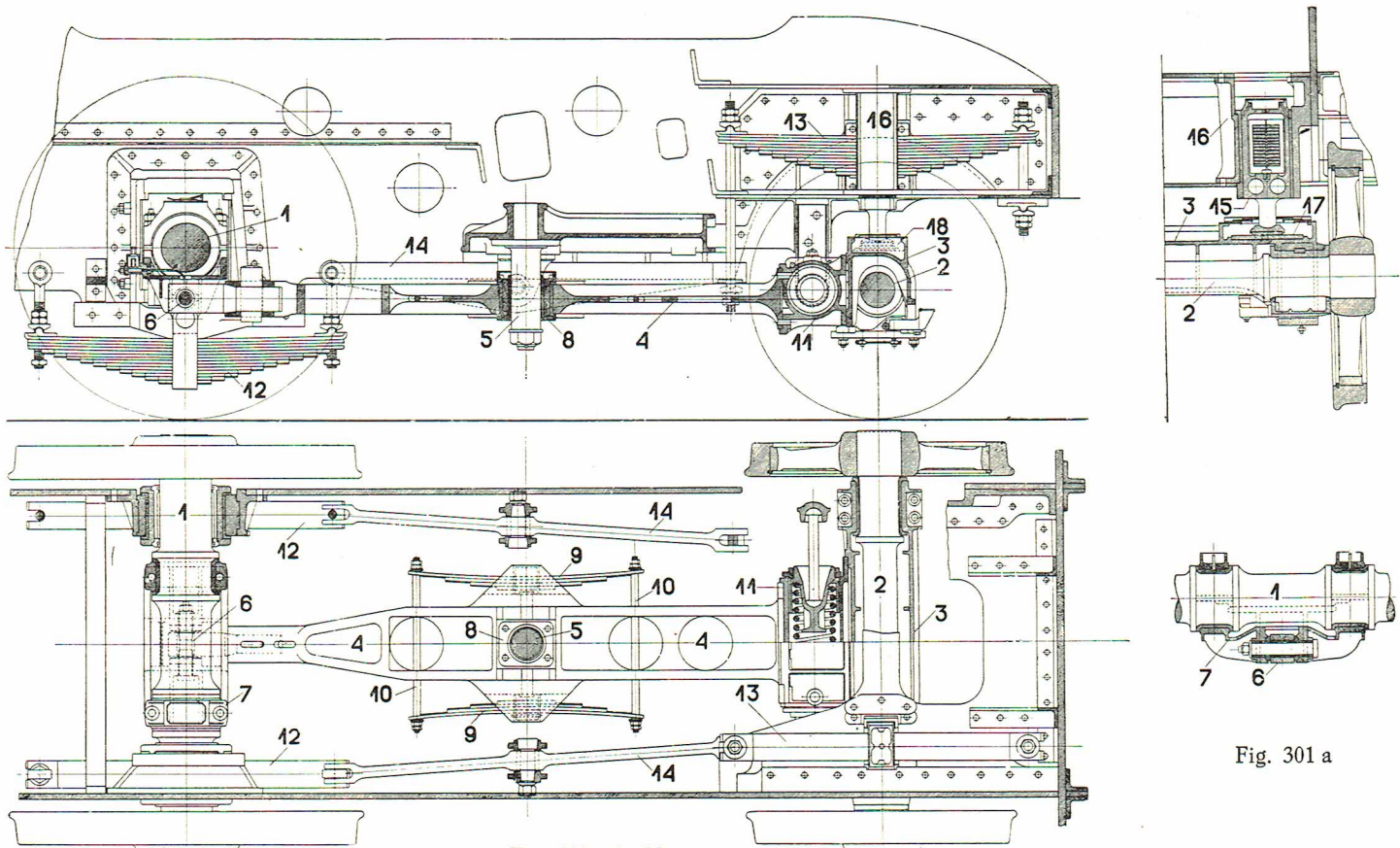

Fig. 301 1:30

Fig. 301 a



Fig. 302

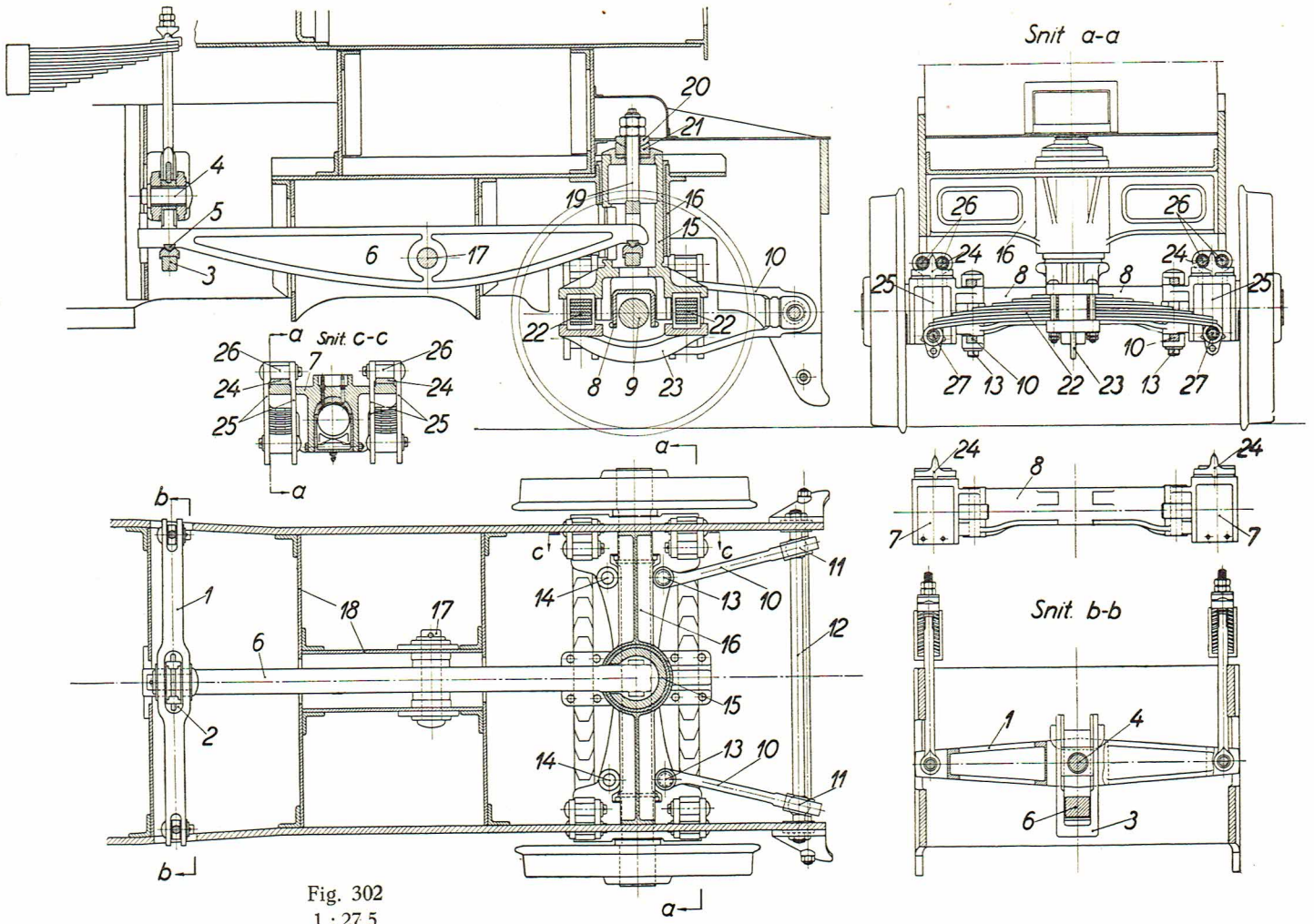

Fig. 302  
1 : 27,5

Fig. 303

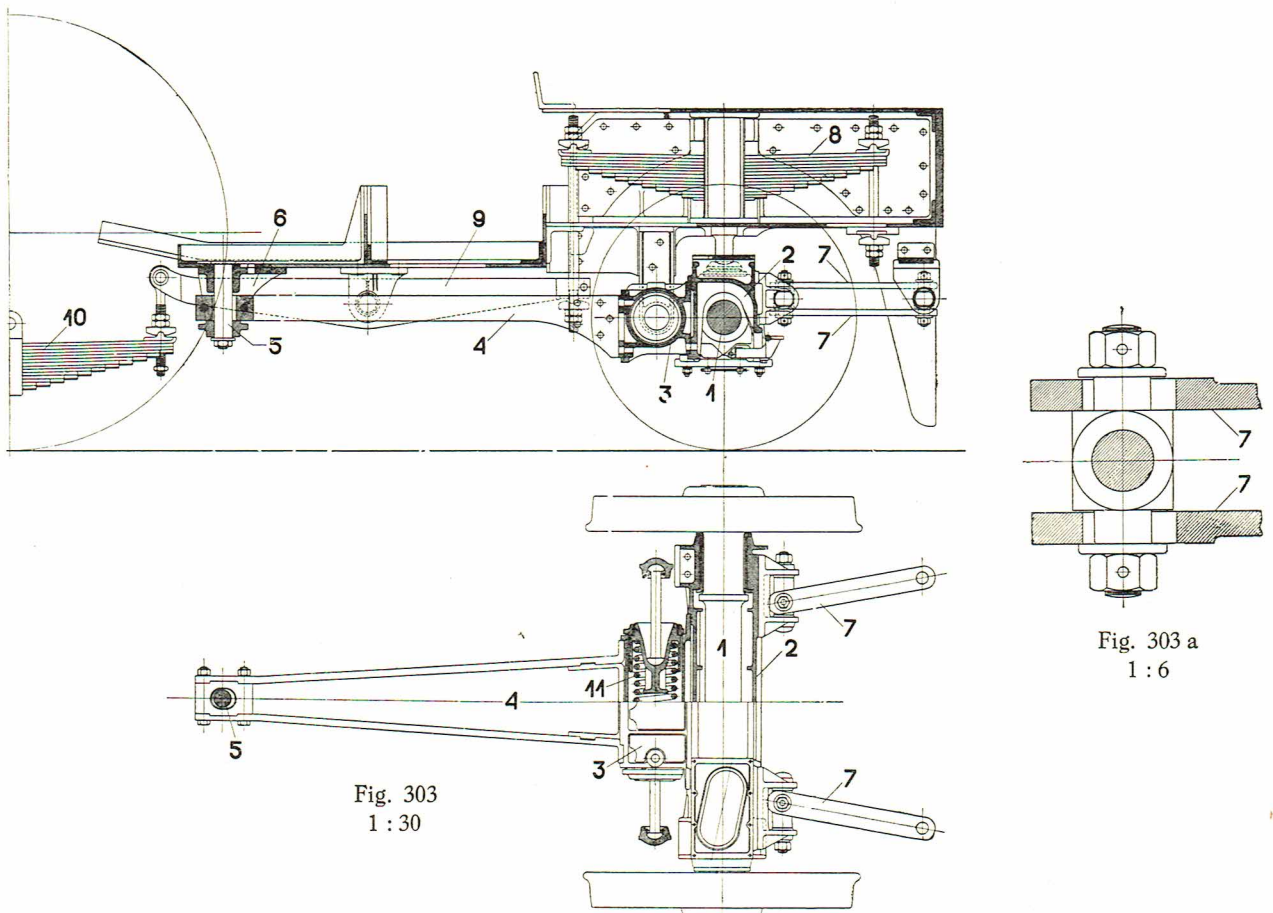

Fig. 303  
1 : 30

Fig. 303 a  
1 : 6



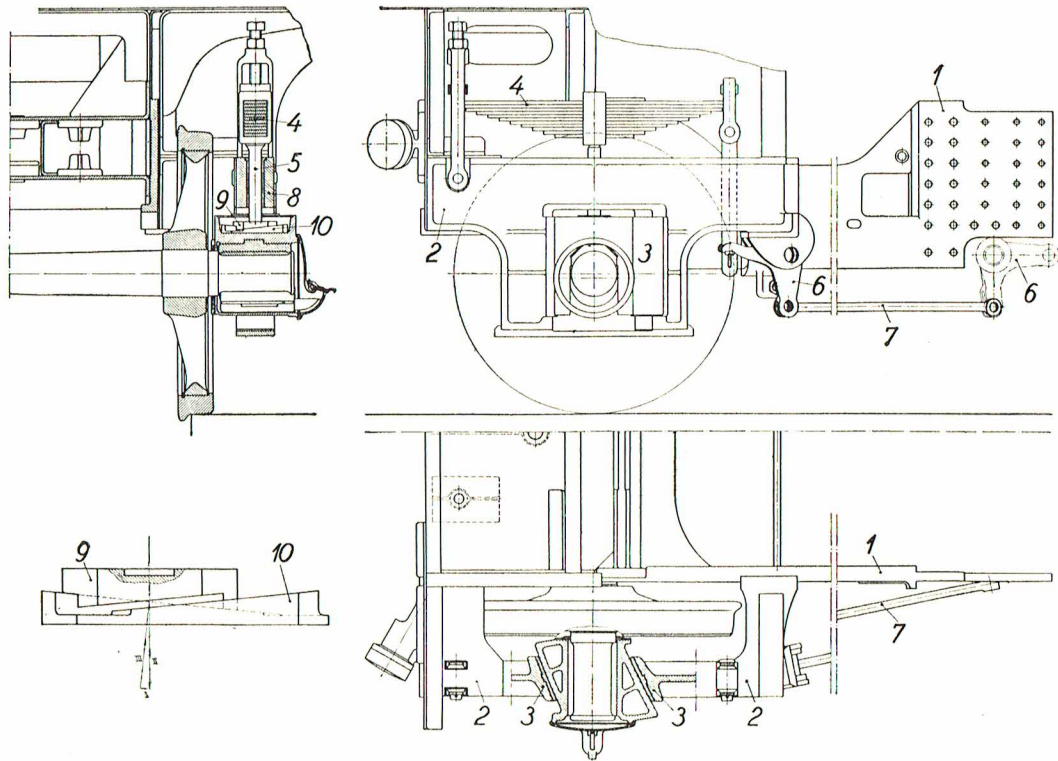

Fig. 304 1:30

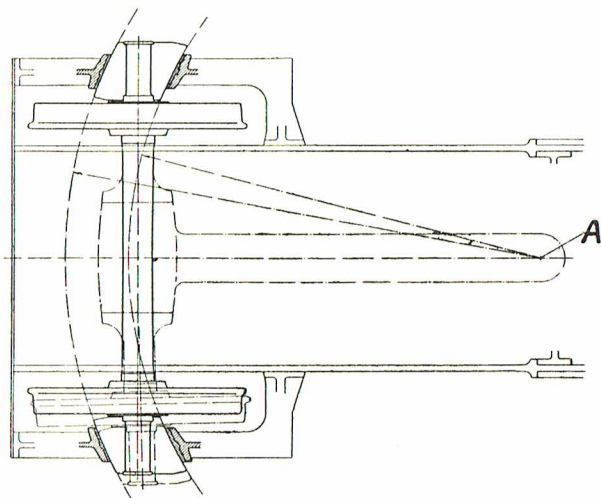

Fig. 304 a

Fig. 304—304 a

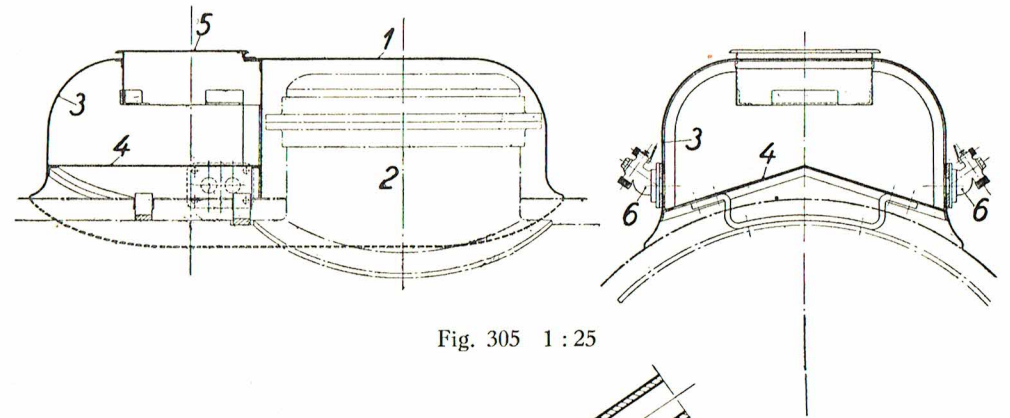

Fig. 305 1:25

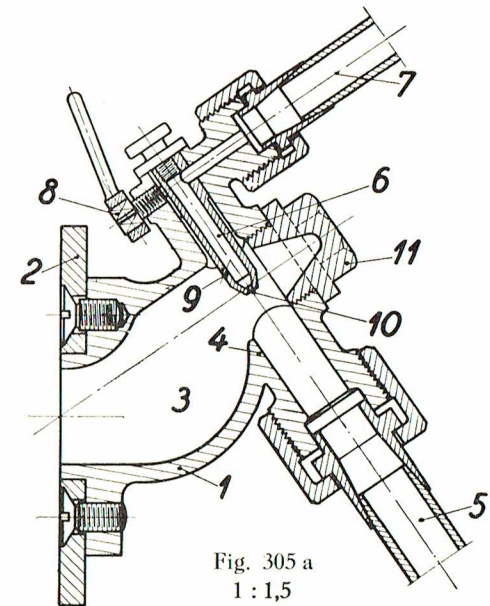

Fig. 305 a  
1:1,5

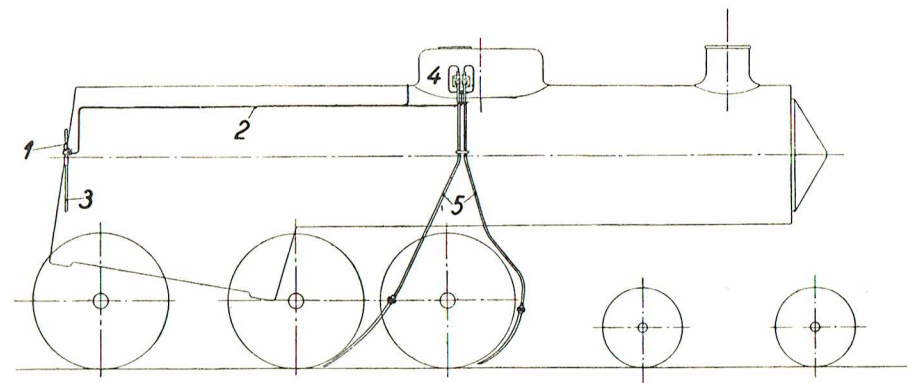

Fig. 306

Fig. 305—306



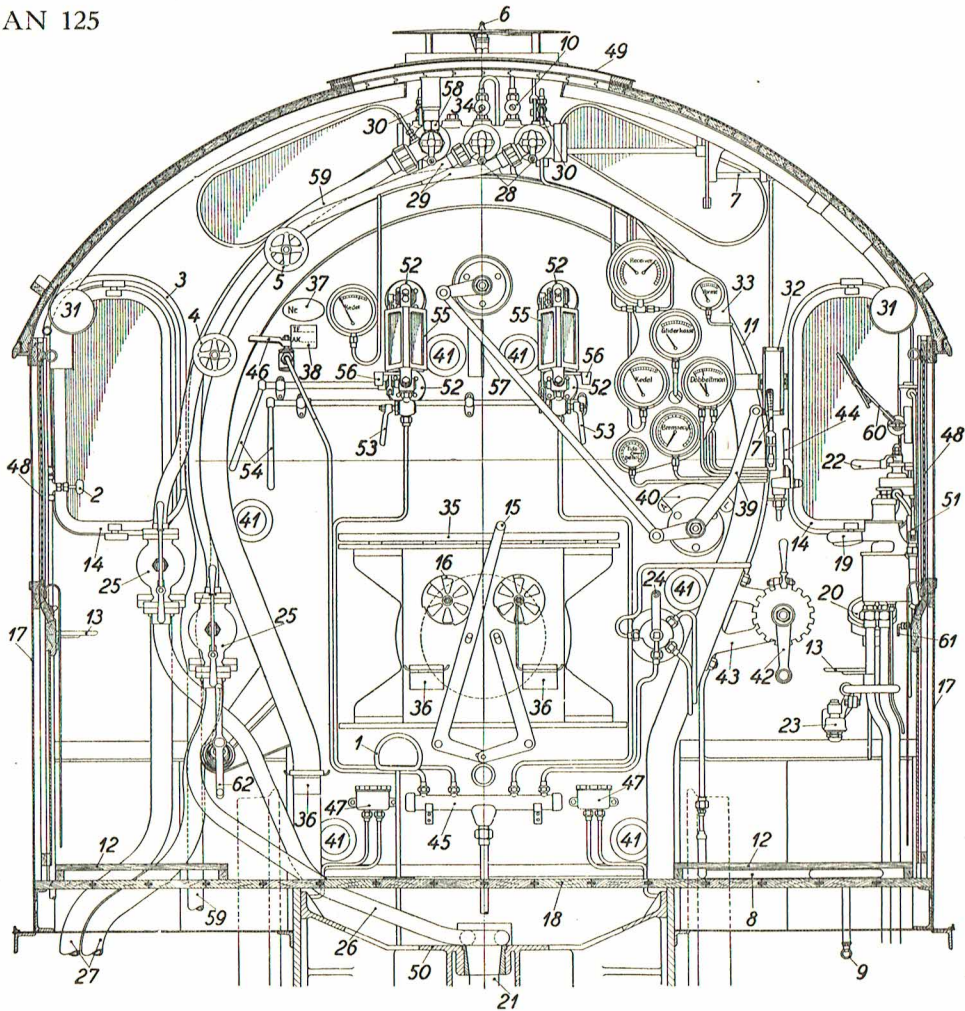

Fig. 307 1 : 25

- |                                |   |   |
|--------------------------------|---|---|
| 1. Askekasse, Træk for         | 23. Hurtigvirkende Reduktionsventil     | 42. Styringskrue, Arm for               |
| 2. — Ventil for Vanding af     | 24. Igangsætnings- og Udblæsningsglider | 43. — Buk for                           |
| 3. — Rør for Vanding af        | 25. Injektor                            | 44. Sandingsventil                      |
| 4. Blæserventil, Træk for      | 26. — Sugerør for                       | 45. Samlekasse for Udblæsning           |
| 5. Dynamo, Træk for            | 27. — Spilderør for                     |   |
| 6. Fløjte                      | 28. — Dampventil for                    |   |
| 7. — Træk for                  | 29. — Damprør for                       |   |
| 8. Fodvarmer                   | 30. Kedelmanometer, Hane for            |   |
| 9. — Vandaftapning for         | 31. Lagendaaser                         |   |
| 10. — Dampventil for           | 32. La. Kasse                           |   |
| 11. — Damprør for              | 33. Manometertavle                      |   |
| 12. Fodskammel                 | 34. Olicopvarmning, Dampventil for      |   |
| 13. Frokosthylde               | 35. Olicbakke                           |   |
| 14. Frontvindue, drejelig      | 36. Opstigningstrin                     |   |
| 15. Fyrdør, Træk for           | 37. Plade for Kedelnummer               |   |
| 16. — Luftspjæld paa           | 38. — Revisionsdato                     |   |
| 17. Førerhus                   | 39. Regulator, Træk for                 |   |
| 18. — Gulv i                   | 40. — Stol for                          |   |
| 19. Førerbremsventil, Trykluft | 41. Rensklapper                         |   |
| 20. Hastighedsmaaler           |   |   |
| 21. Hovedbolt                  |   |   |
| 22. Hjælpebremsventil          |   |   |
|                                |   | 42. Styringskrue, Arm for               |
|                                |   | 43. — Buk for                           |
|                                |   | 44. Sandingsventil                      |
|                                |   | 45. Samlekasse for Udblæsning           |
|                                |   | 46. Skumhane                            |
|                                |   | 47. Smørekasse for Balancer             |
|                                |   | 48. Sidevinduer, gaaende                |
|                                |   | 49. Skydetag med Luftspjæld             |
|                                |   | 50. Trækkasse                           |
|                                |   | 51. Udaligningsventil                   |
|                                |   | 52. Vandstandsglas, Afspærringshane for |
|                                |   | 53. — Prøvehane for                     |
|                                |   | 54. — Træk for                          |
|                                |   | 55. — Beskyttelsesglas for              |
|                                |   | 56. — Lygteholder for                   |
|                                |   | 57. — Afskærmningsplade for             |
|                                |   | 58. Varmeventil                         |
|                                |   | 59. Varmeledning                        |
|                                |   | 60. Vinduesvisker                       |
|                                |   | 61. — Hane for                          |
|                                |   | 62. Vipperist, Træk for                 |

Fig. 307

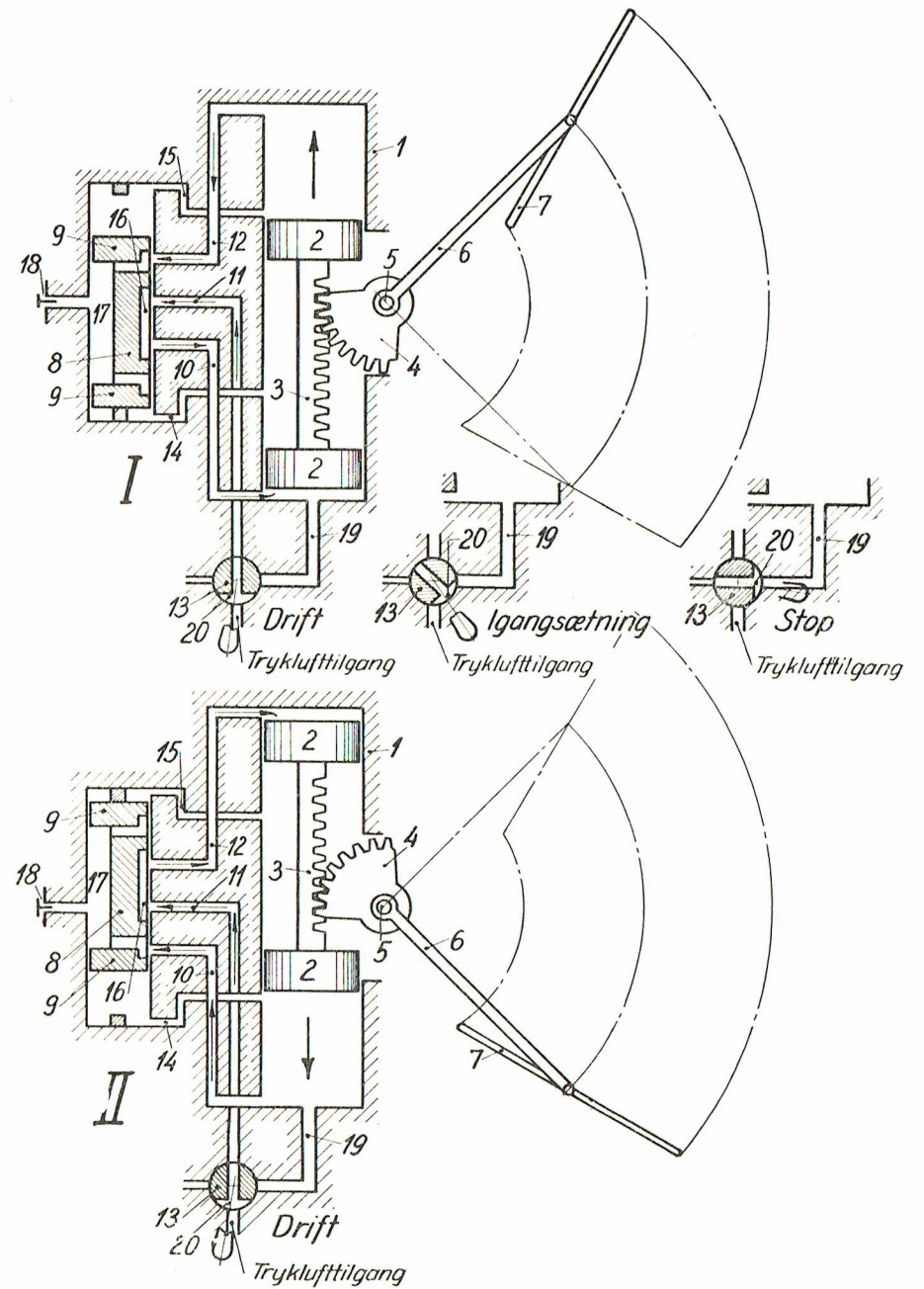

Fig. 307 a

Fig. 307 a



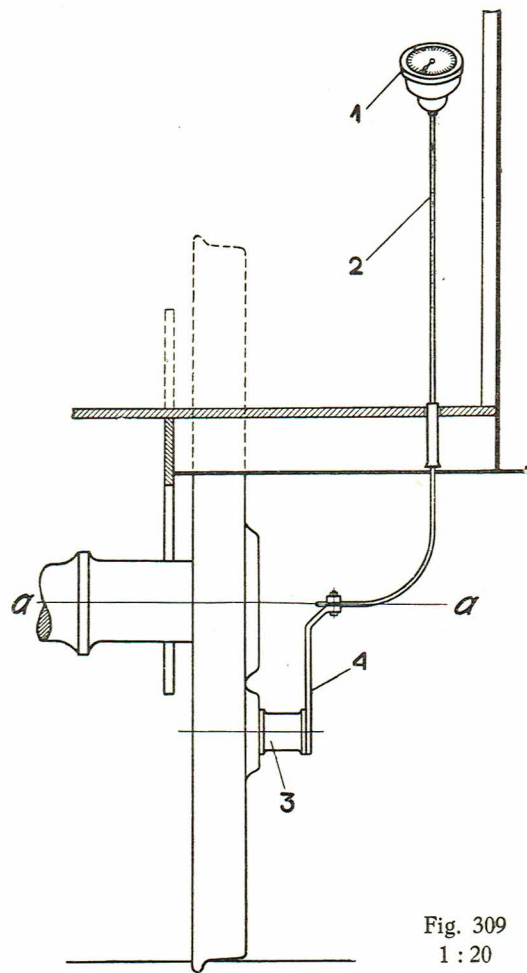

Fig. 309  
1 : 20

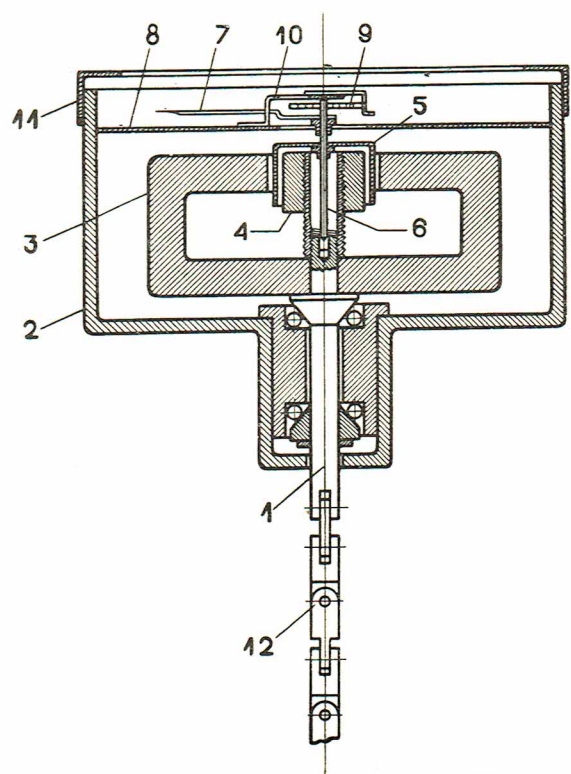

Fig. 308

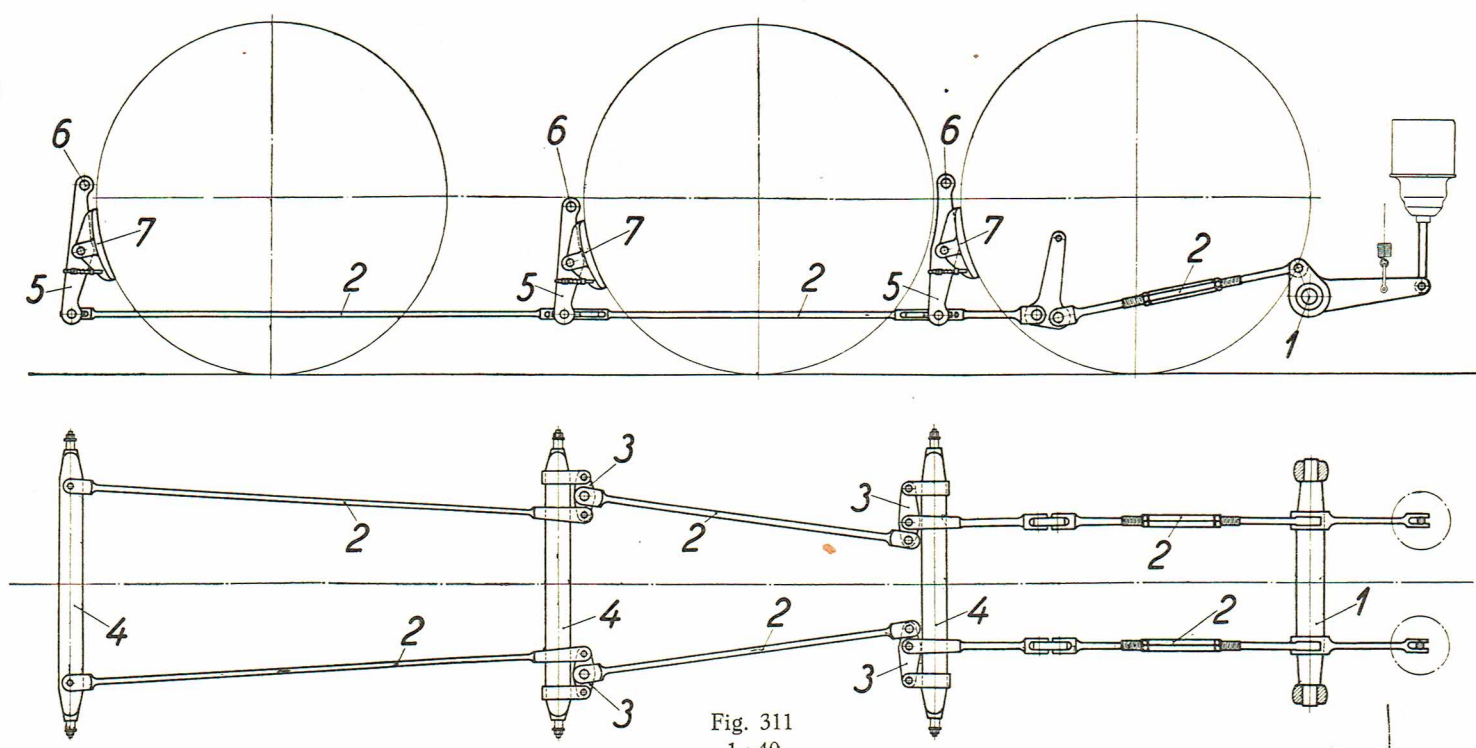

Fig. 311  
1 : 40

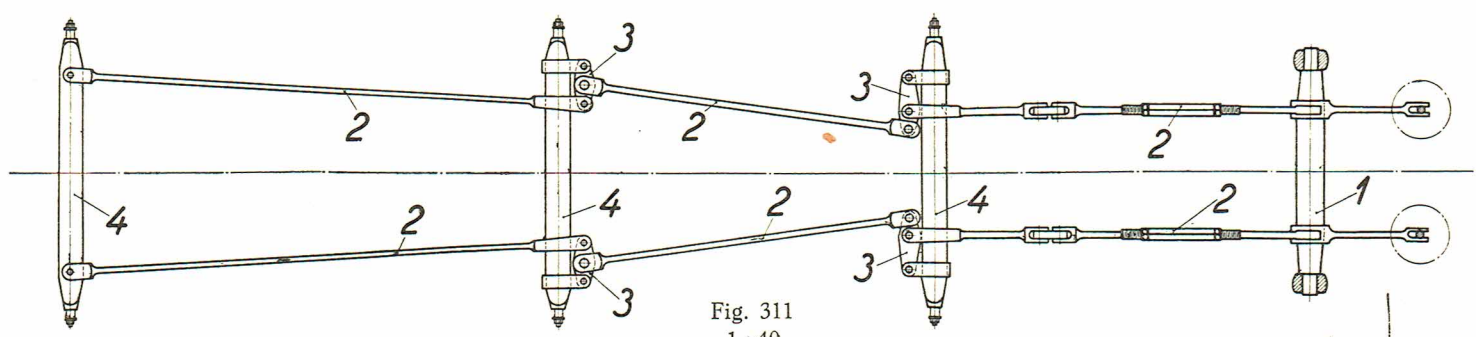
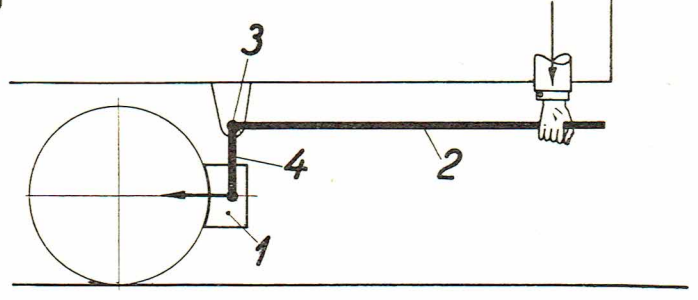

Fig. 310



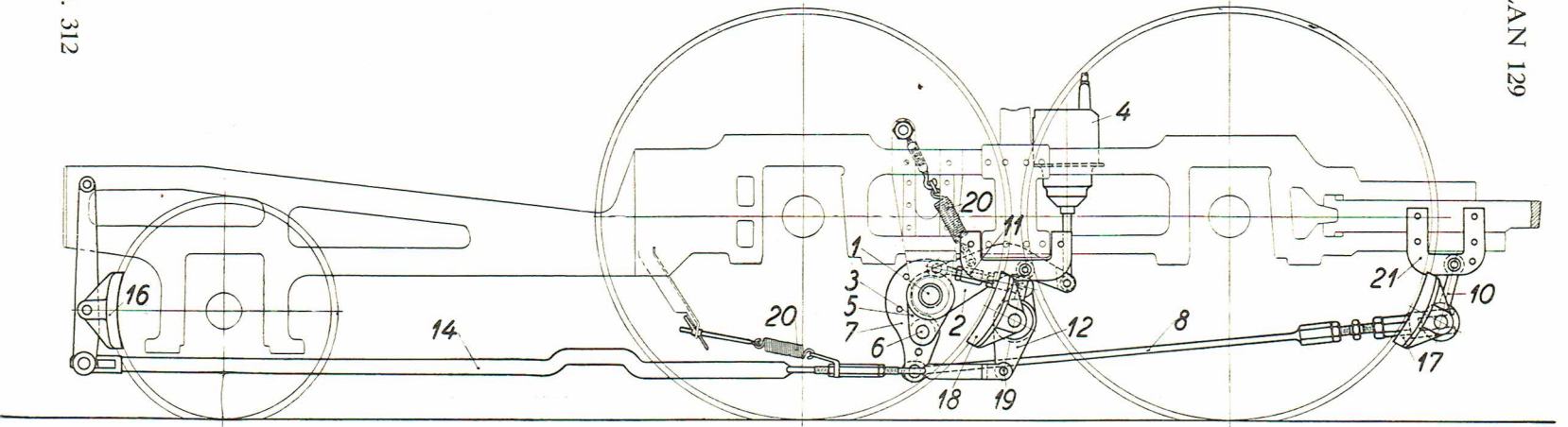

Fig. 312

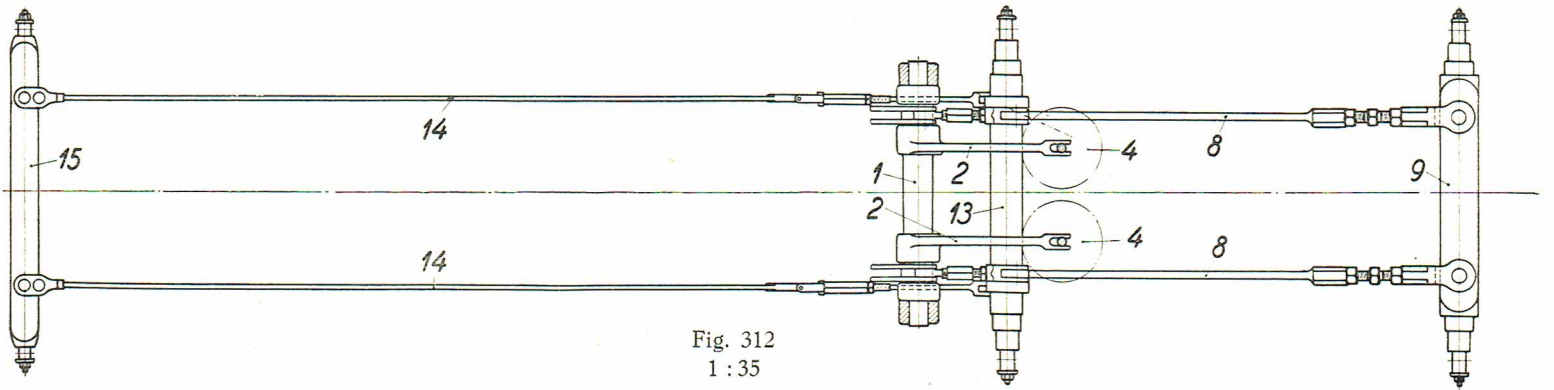

Fig. 312  
1:35

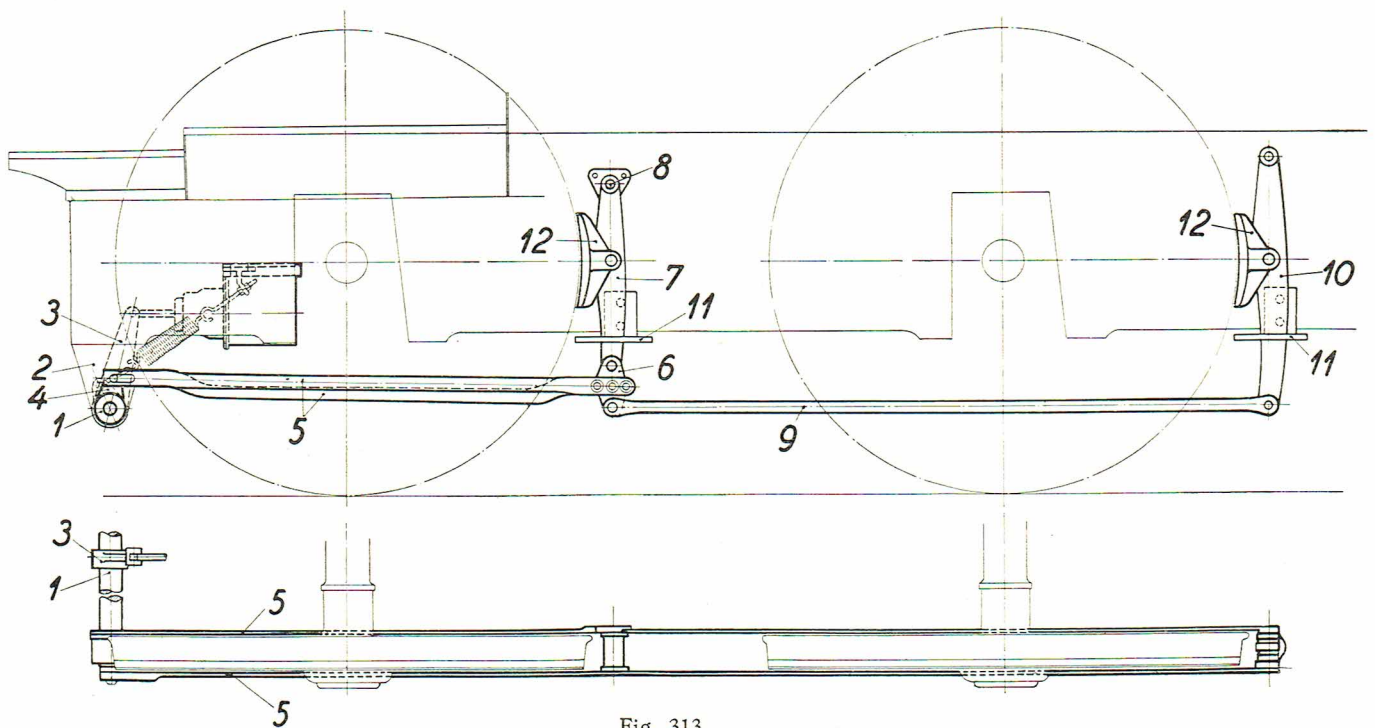

Fig. 313  
1:30

Fig. 313



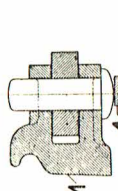
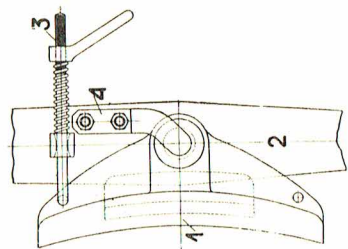

Fig. 315 1:10

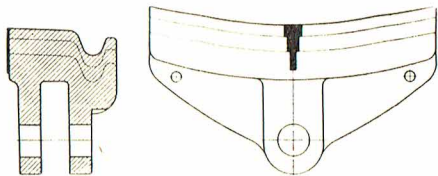

Fig. 316 1:10

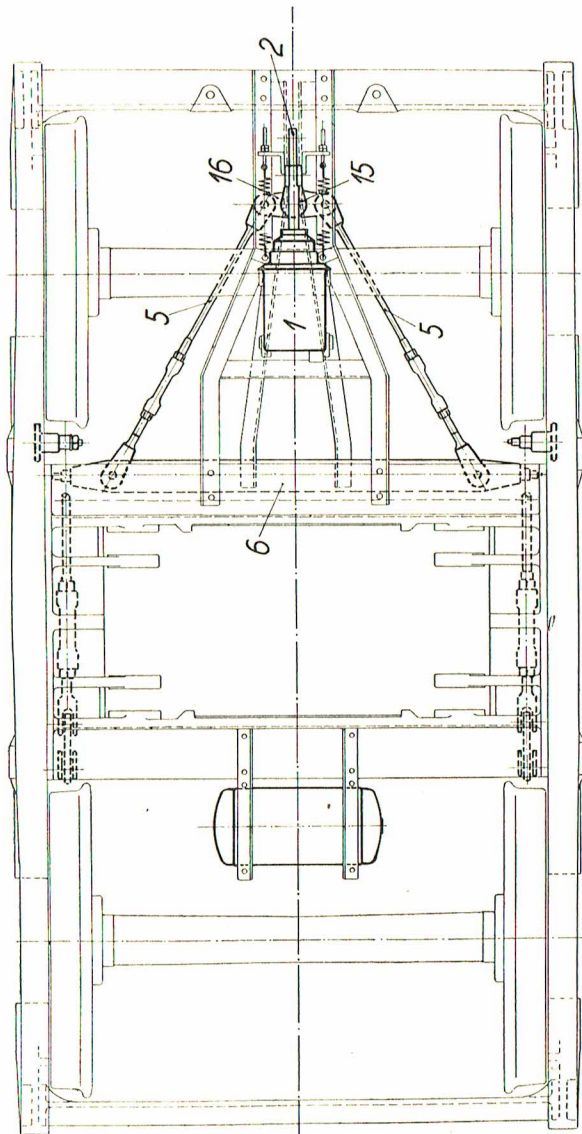
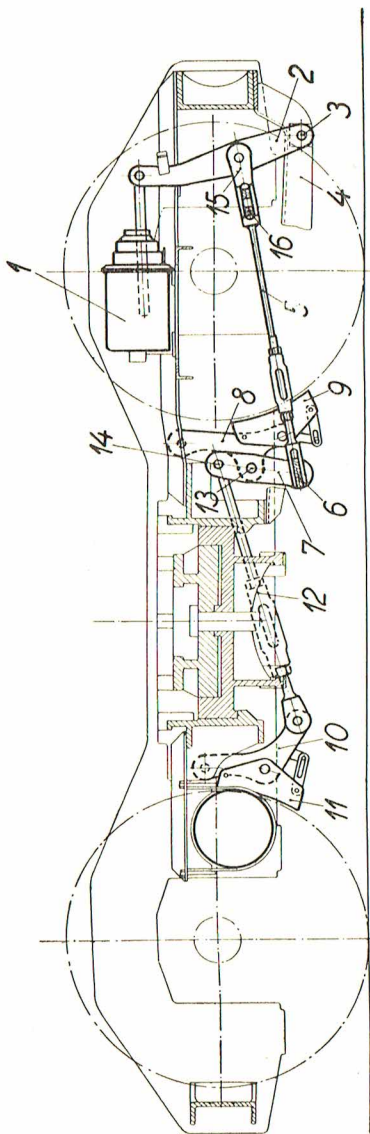

Fig. 314 1:25

Fig. 314—316

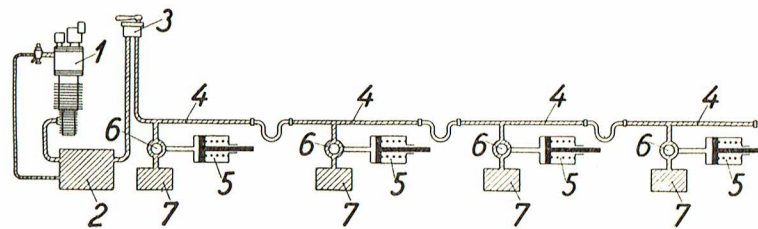

Fig. 317 a

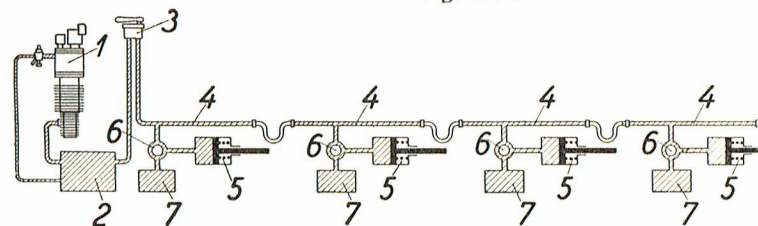
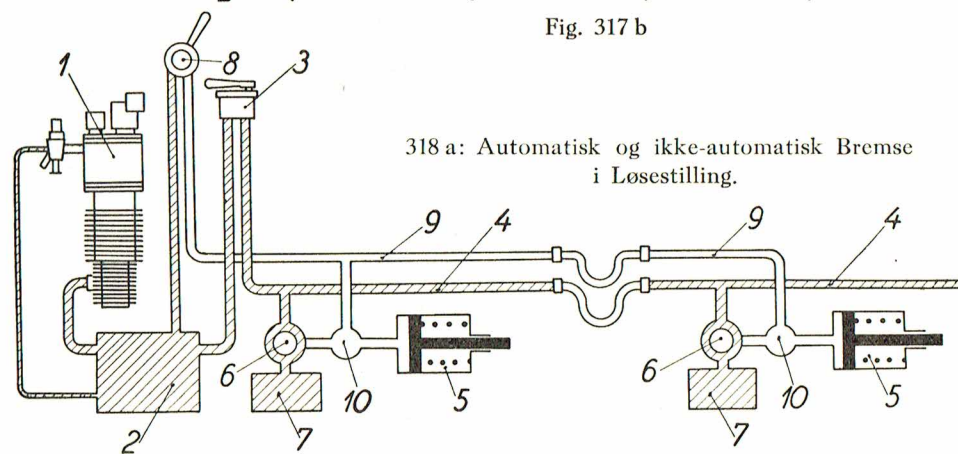
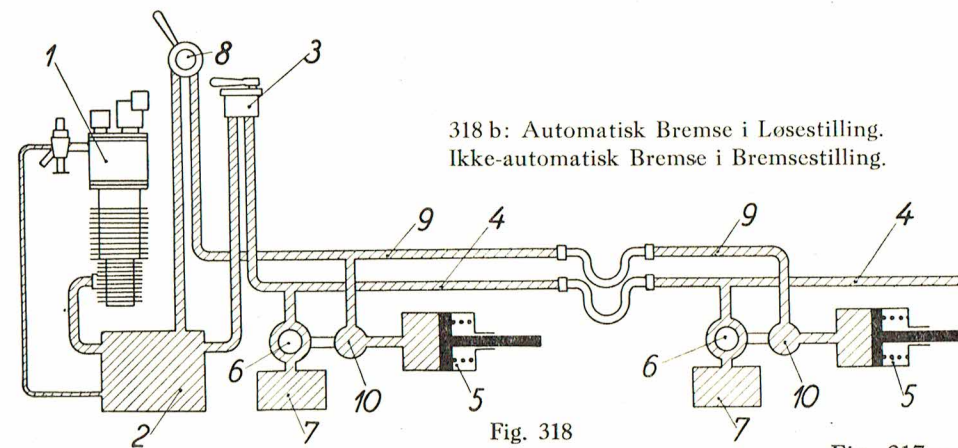

Fig. 317 b



318 a: Automatisk og ikke-automatisk Bremse i Løsestilling.



318 b: Automatisk Bremse i Løsestilling. Ikke-automatisk Bremse i Bremsstilling.

Fig. 318

Fig. 317 a—318



Fig. 319

- 1. Totrins Luftpumpe med P-Styring.
- 2. Luftpumpestartventil.
- 3. Dampafspærringsventil.
- 4. Hovedluftbeholdere.
- 5. Bremscylindre.
- 6. Hjælpeluftbeholdere.
- 7. E-Styreventil.
- 8. Dobbeltkontraventil.

- 9. GP-Hane.
- 10. Afspærringshane.
- 11. Automatisk Førerventil.
- 12. Udligningsbeholder.
- 13. Tidsbeholder.

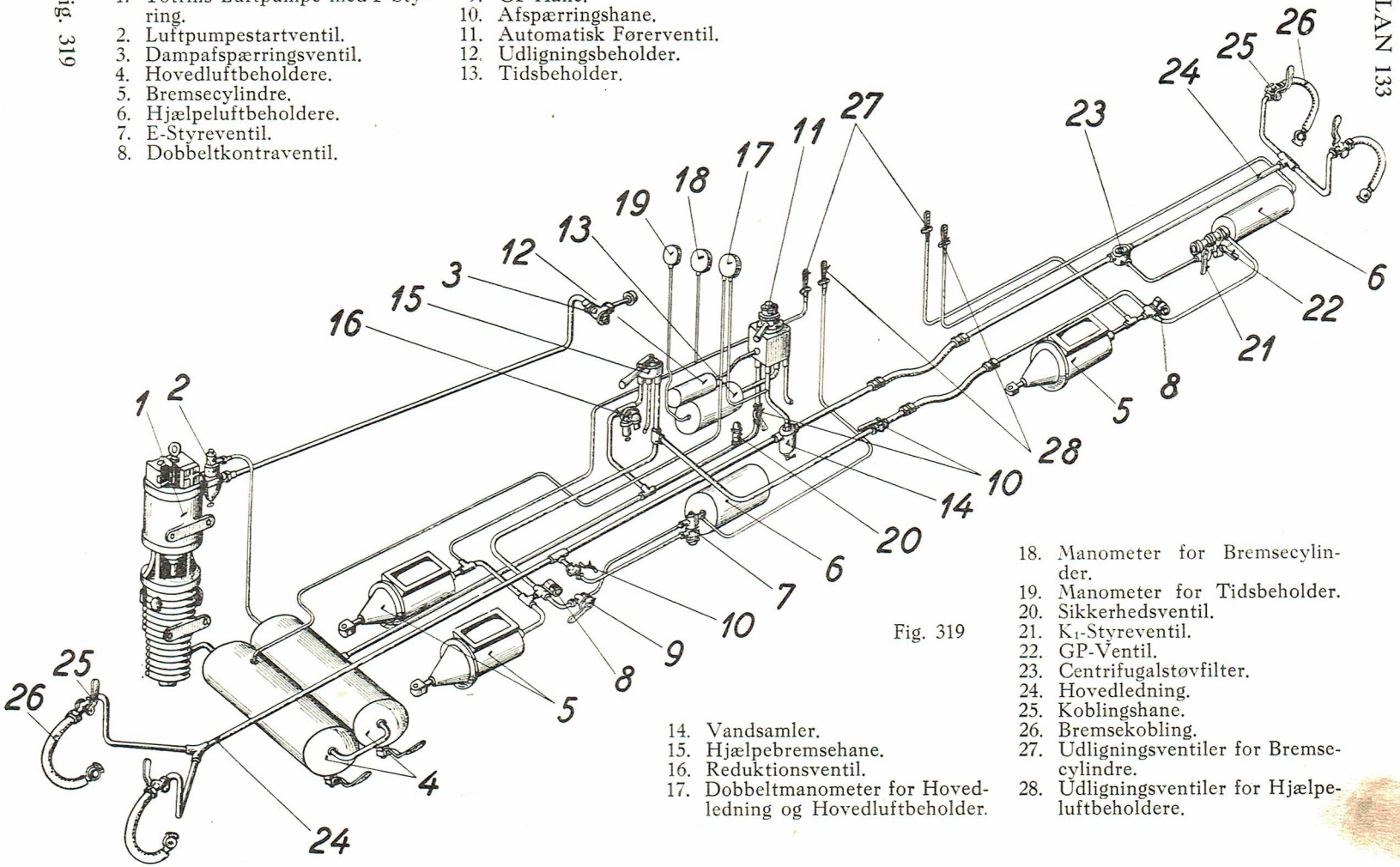

- 14. Vandsamler.
- 15. Hjelpebremsehane.
- 16. Reduktionsventil.
- 17. Dobbeltmanometer for Hovedledning og Hovedluftbeholder.
- 18. Manometer for Bremscylinder.
- 19. Manometer for Tidsbeholder.
- 20. Sikkerhedsventil.
- 21. K<sub>1</sub>-Styreventil.
- 22. GP-Ventil.
- 23. Centrifugalstøvsfilter.
- 24. Hovedledning.
- 25. Koblingshane.
- 26. Bremskobling.
- 27. Udligningsventiler for Bremscylindre.
- 28. Udligningsventiler for Hjelpeluftbeholdere.

Fig. 319

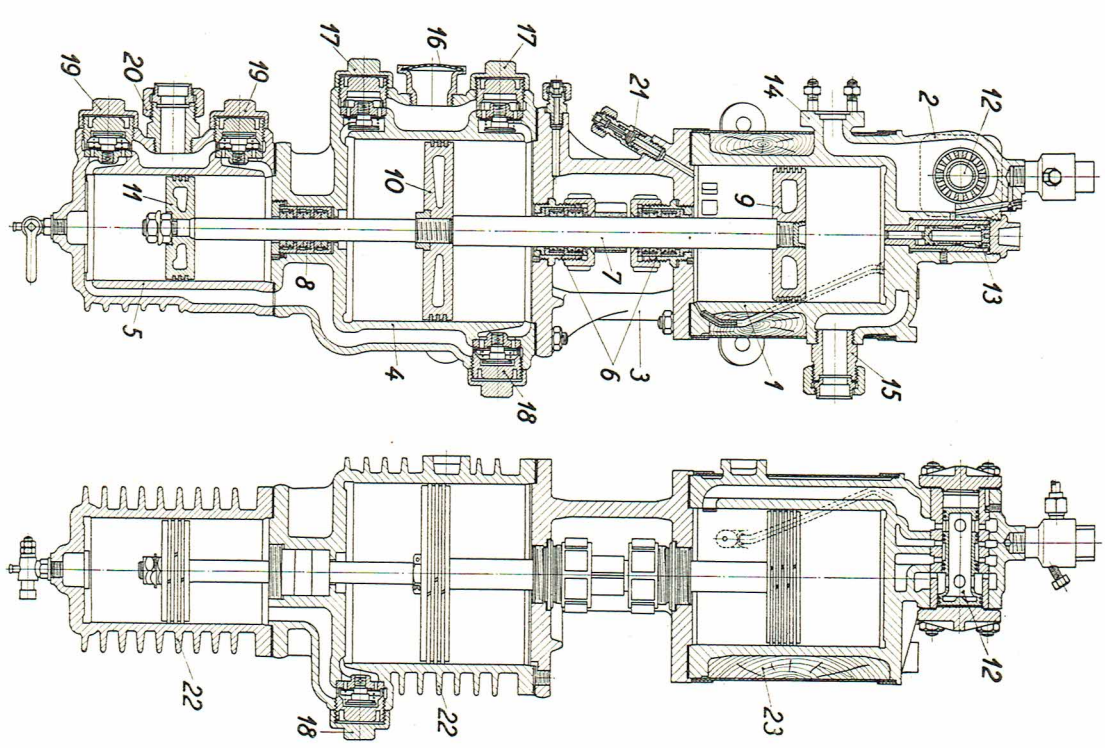

Fig. 320  
1 : 10

Fig. 320



Kraftdamp     
  Spildedamp     
  Blandingsdamp

DE: Indgang for Kraftdamp  
 DA: Udgang for Spildedamp

**Hovedglider**  
 $r_1$   $r_2$   $r_3$ : Fordelingskamre i Hovedglider  
 $o_1$   $o_2$ : Boringer i Hovedglider  
 A og B: Hovedslyrekamre  
 1 til 6: Styreledninger

**Hjælpeglider**  
 $r_4$   $r_5$ : Fordelingskamre i Hjælpeglider  
 C og D: Hjælpestyrekamre

**Dampcylinder**  
 Do: Dampcylinderrum over } Dampstempel  
 Du: Dampcylinderrum under }

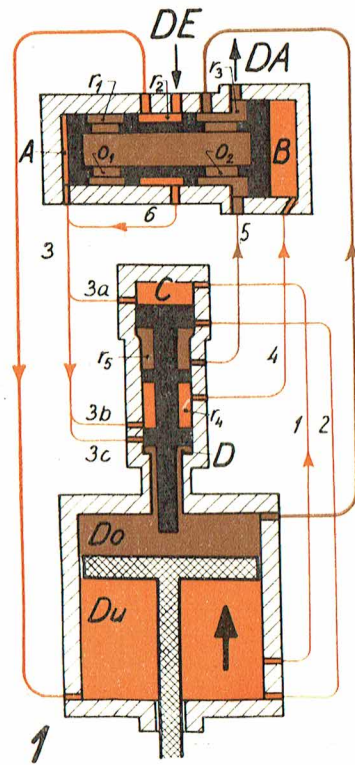

Fig. 321

Fig. 321

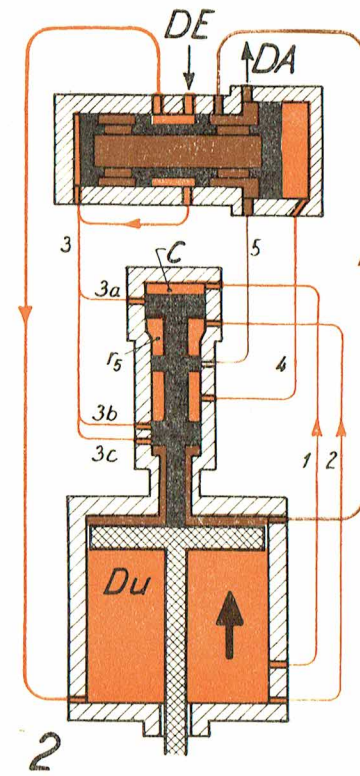

Fig. 321

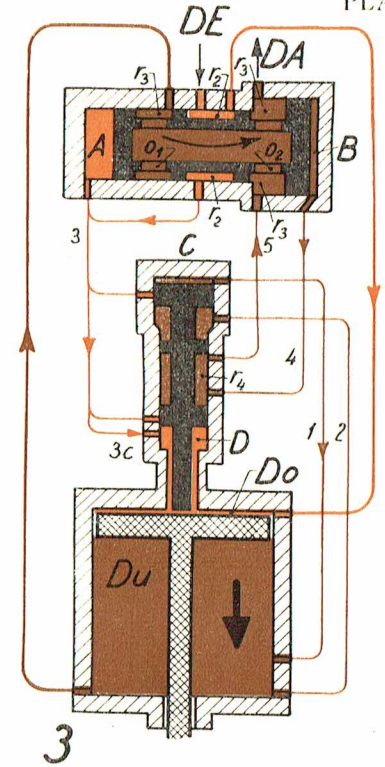

Fig. 321 (fortsat)



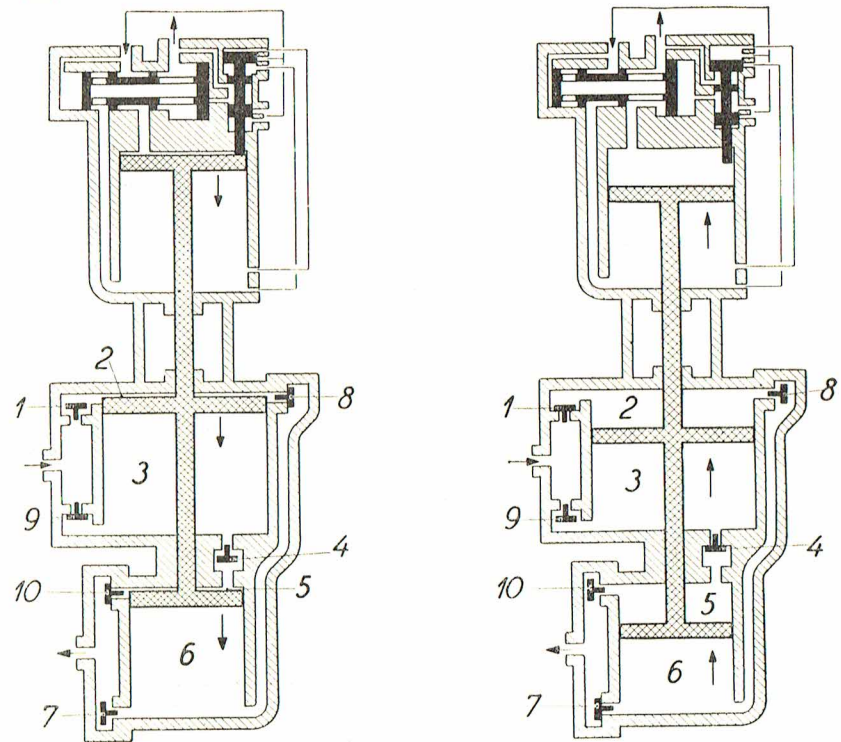

Fig. 322 a

Fig. 322 b

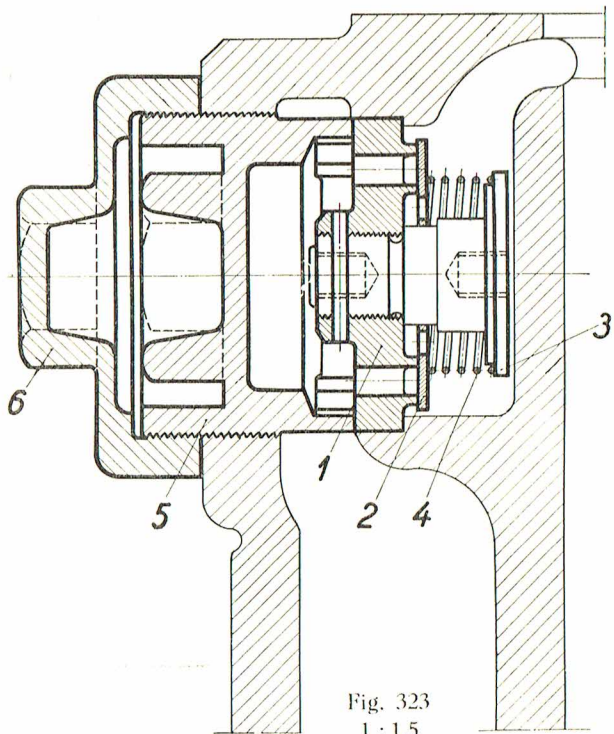

Fig. 323  
1 : 1,5

Fig. 322 a—323

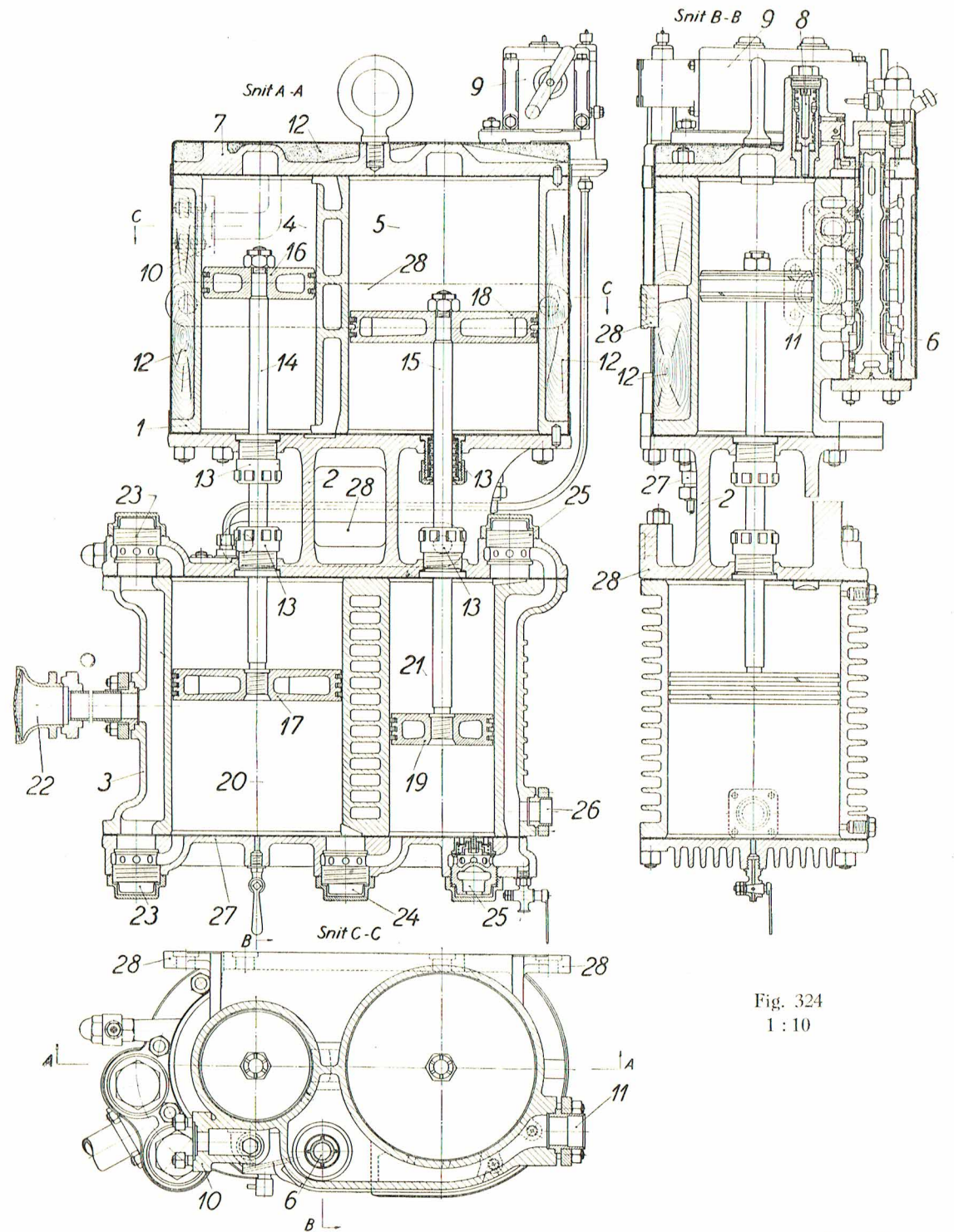

Fig. 324  
1 : 10

Fig. 324



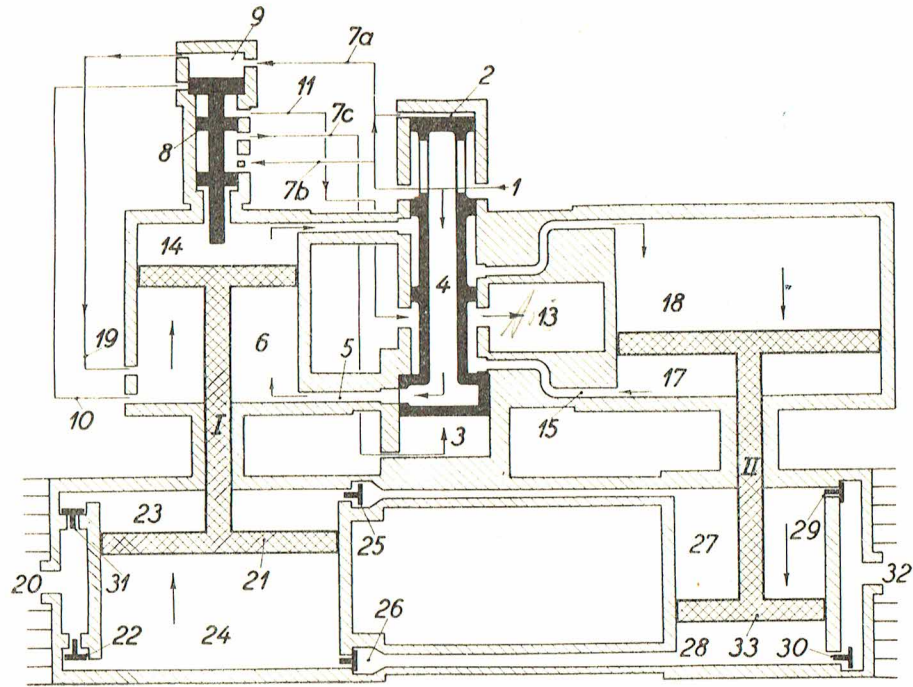

Fig. 325 a

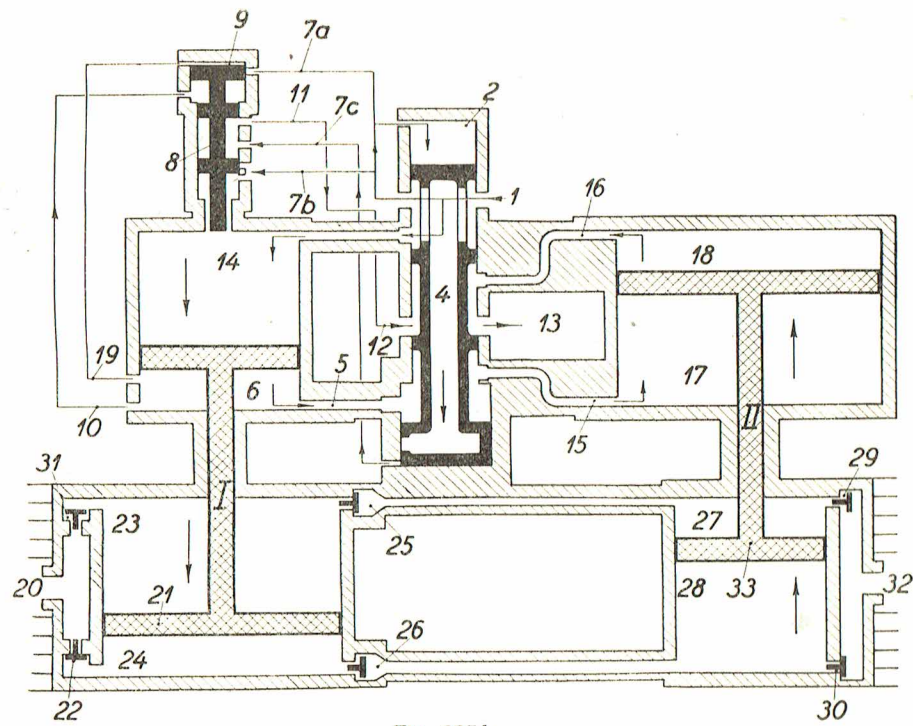
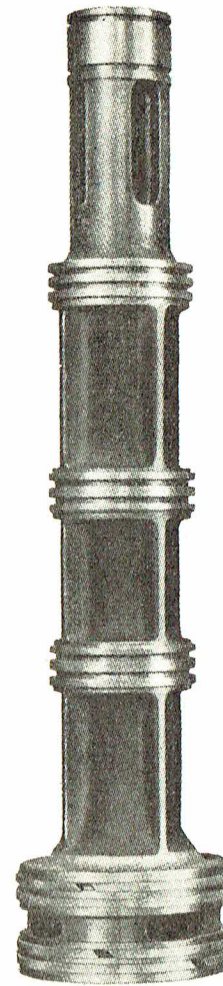
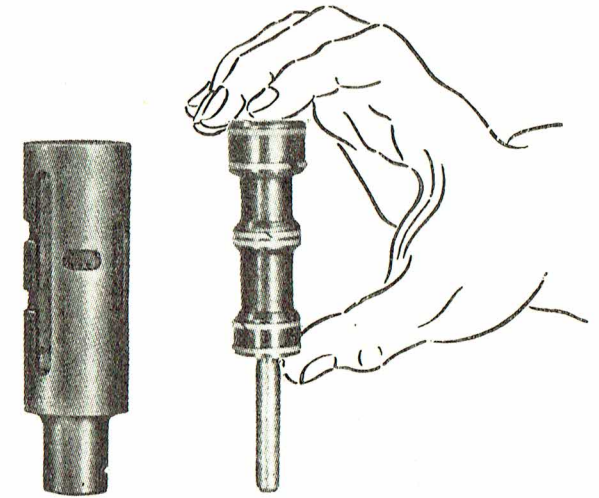

Fig. 325 b

Fig. 325 a—325 b



Hovedglider



Hjælpeglider med Bøsning

P-Styring for  
Dobbelt-Compound-Luftpumpen

Fig. 326

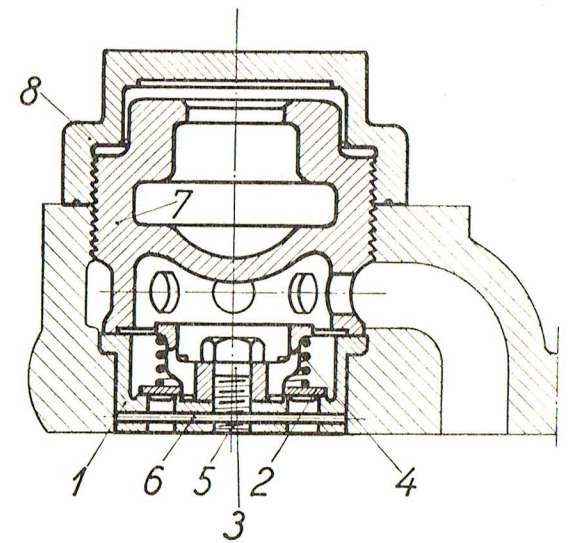

Fig. 327 1:2

Fig. 326—327



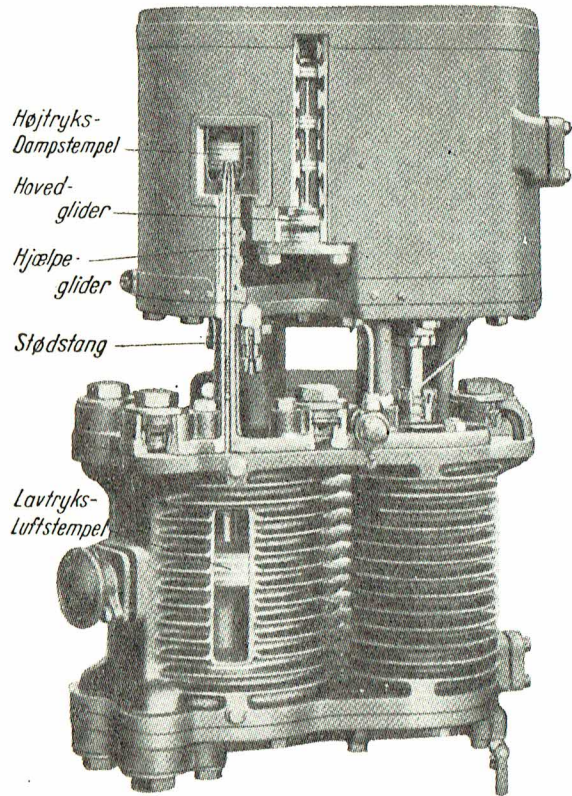

Fig. 328

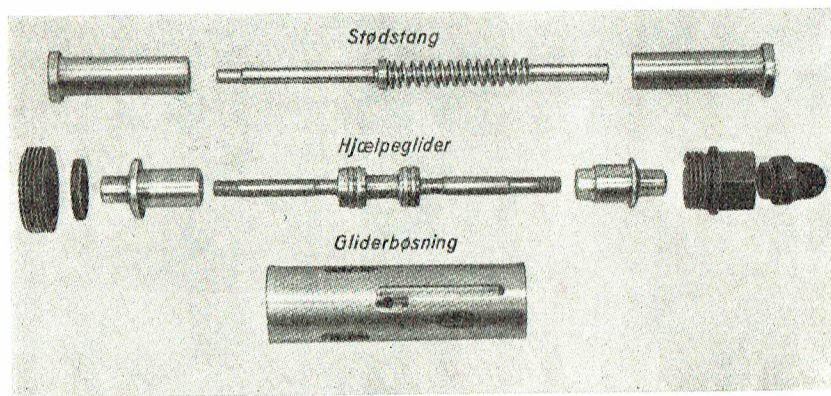

Fig. 329

Fig. 328—329

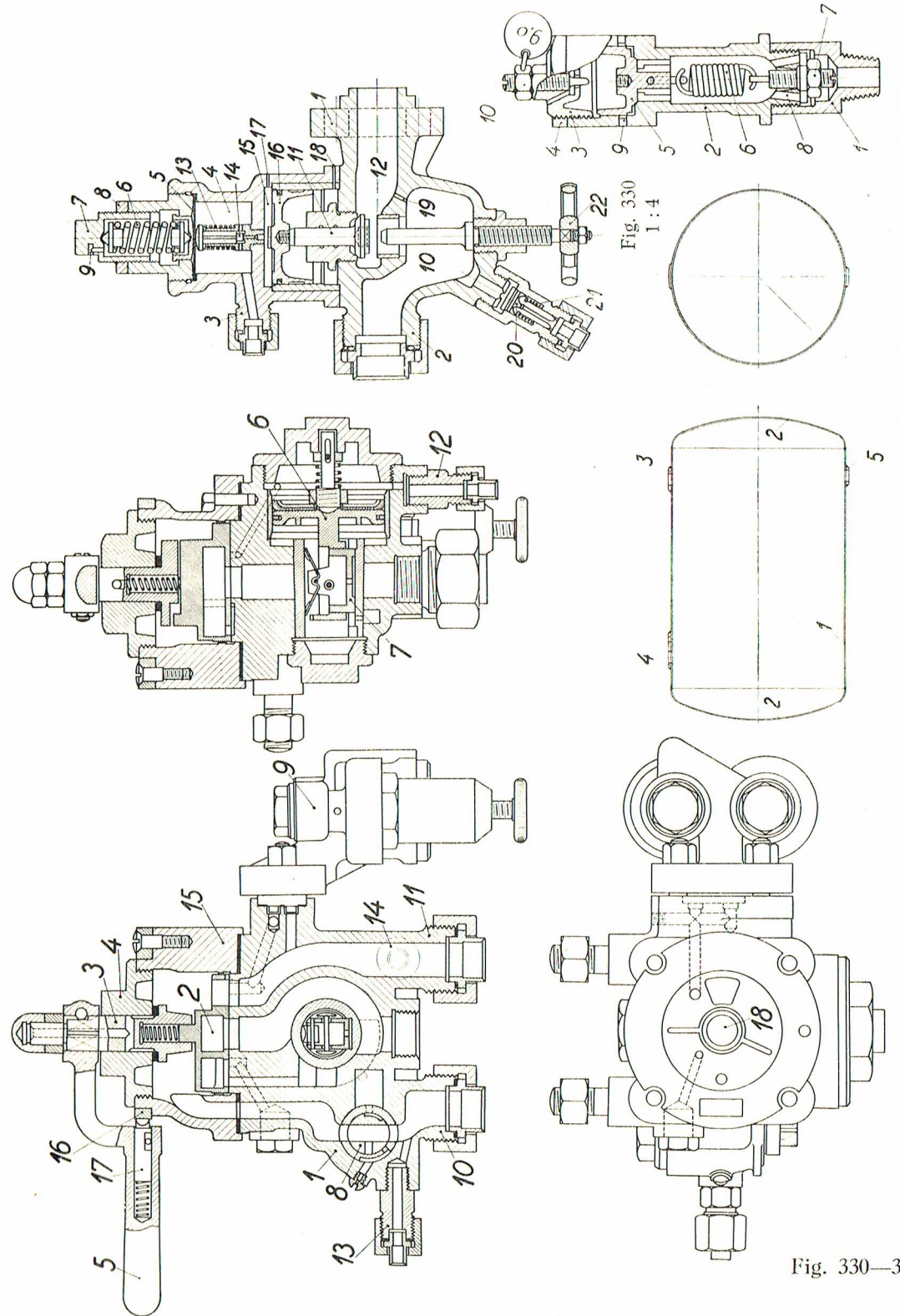

Fig. 332 1:3

Fig. 330 1:4

Fig. 331 1:25

Fig. 333 1:4,5

Fig. 330—333



Førerventilhaandtagets Stillinger

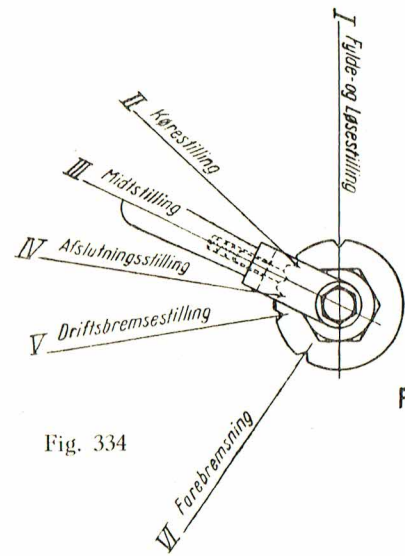
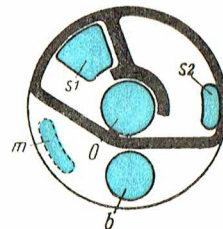
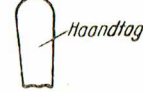

Fig. 334

- Aabninger i det faste Gliderspejl og Hovedbeholderluft
- Aabninger i Drejegliden
- tilvejebragte Luftforbindelser

Drejegliden



Rummet indenfor den sorte Del staar altid i Forbindelse med fri Luft

Fig. 334 b

Faste Gliderspejl

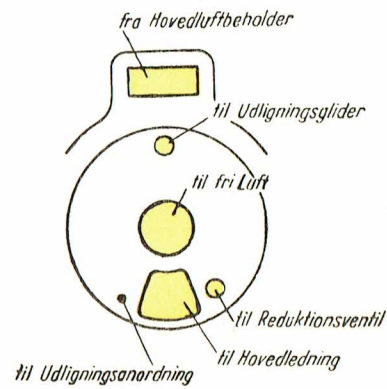

Fig. 334 a

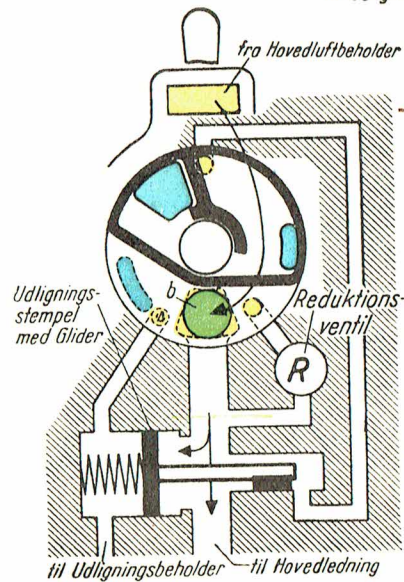

Fig. 334

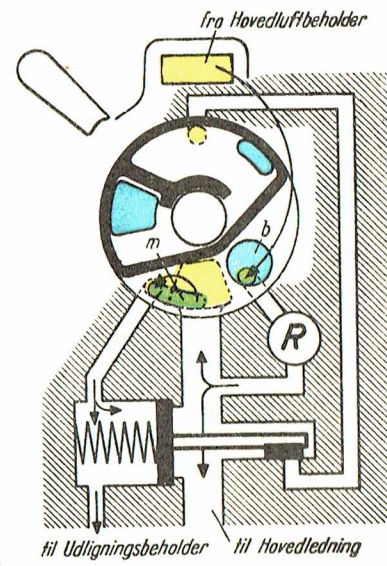
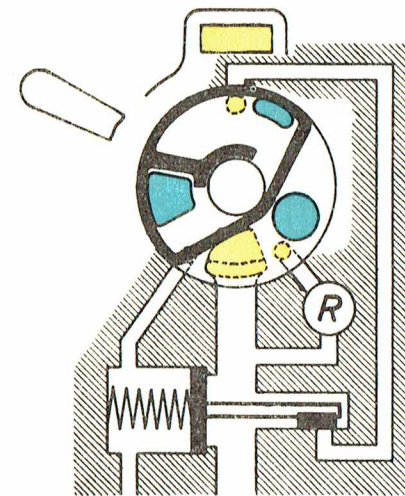
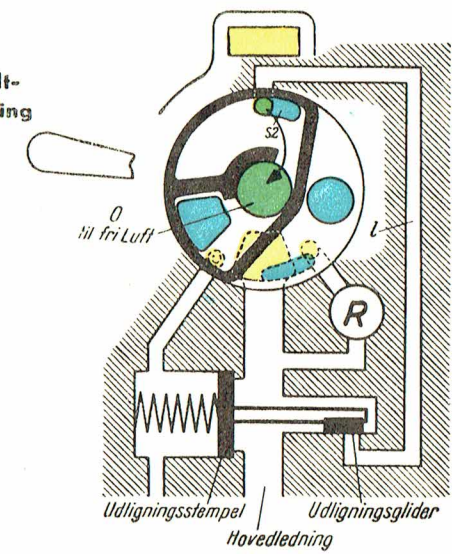

Fig. 334 c



III  
Mid-  
stilling



IV  
Af-  
slutning

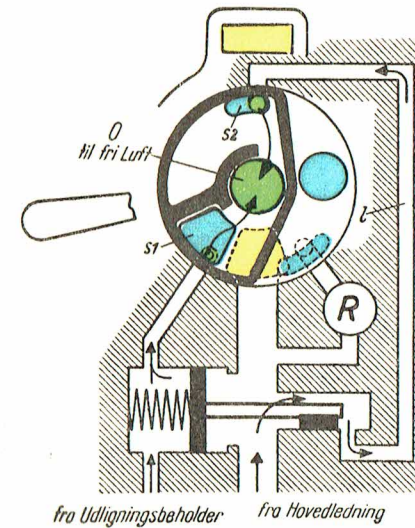

V  
Drifts-  
bremse

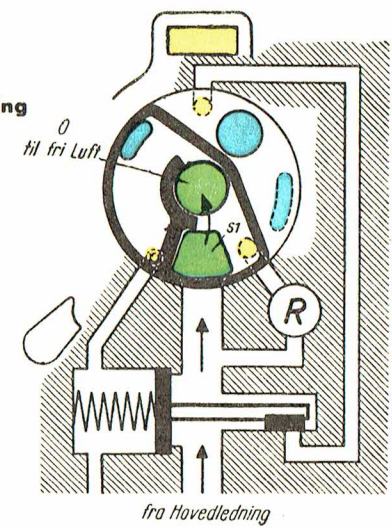

VI  
Fare-  
bremsning

Fig. 334 c

Fig. 334 (fortsat)



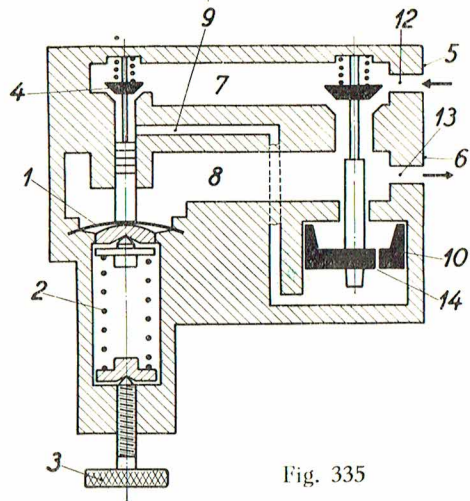

Fig. 335

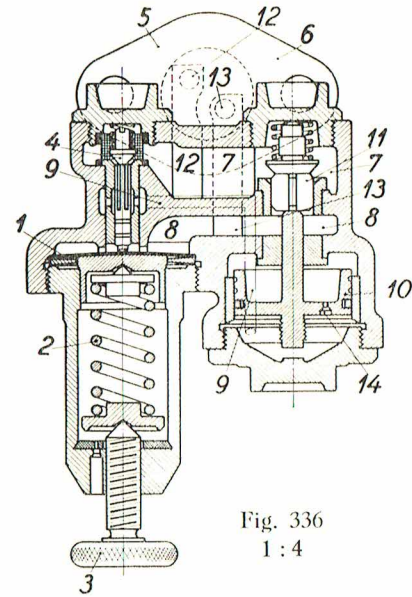

Fig. 336  
1 : 4

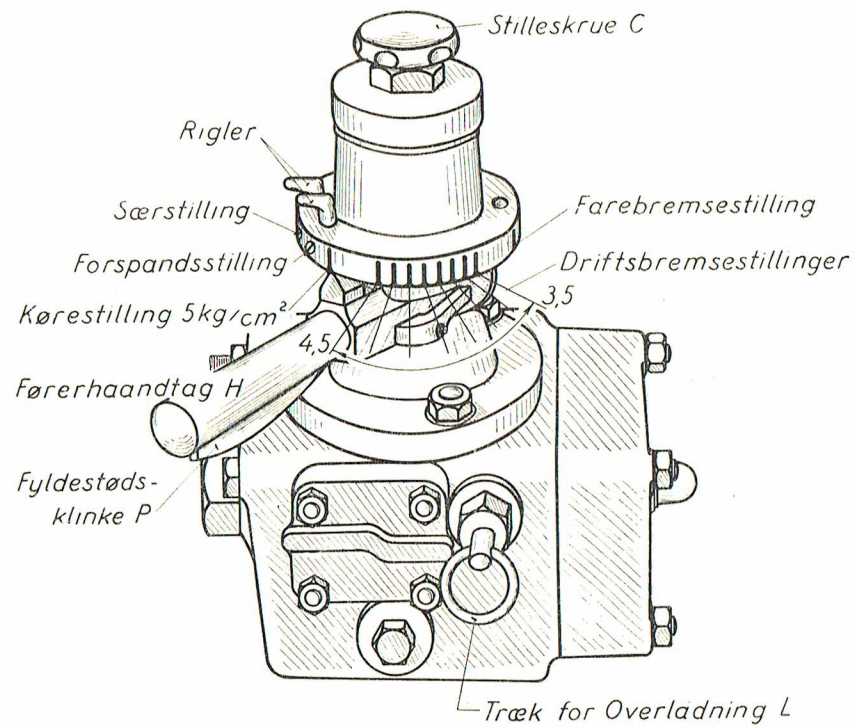

Fig. 337

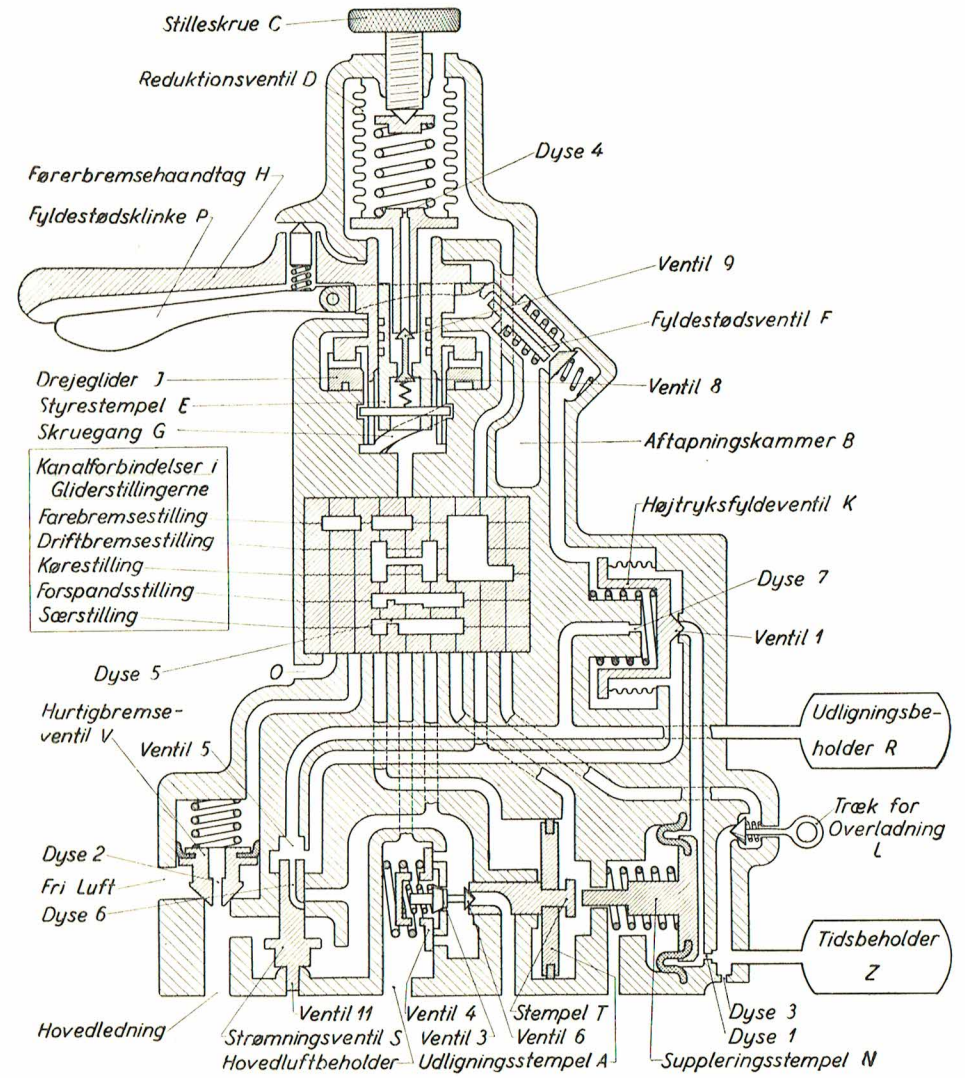

Fig. 338



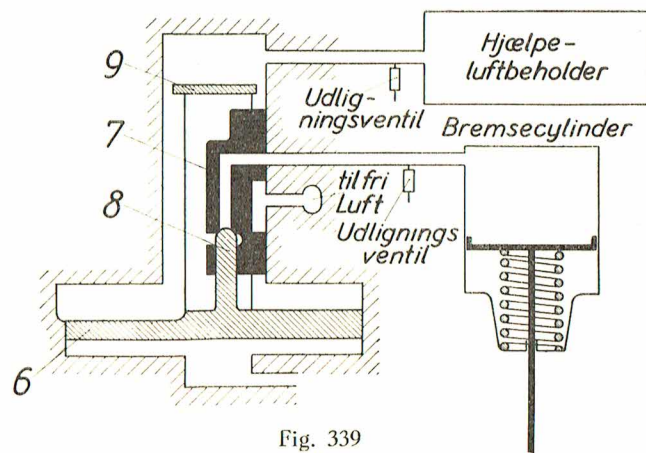
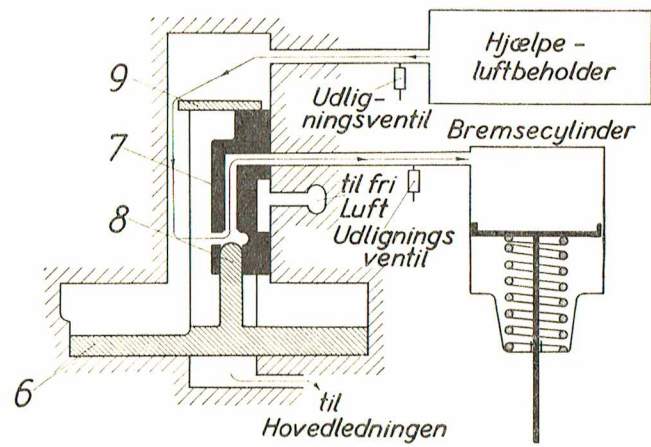
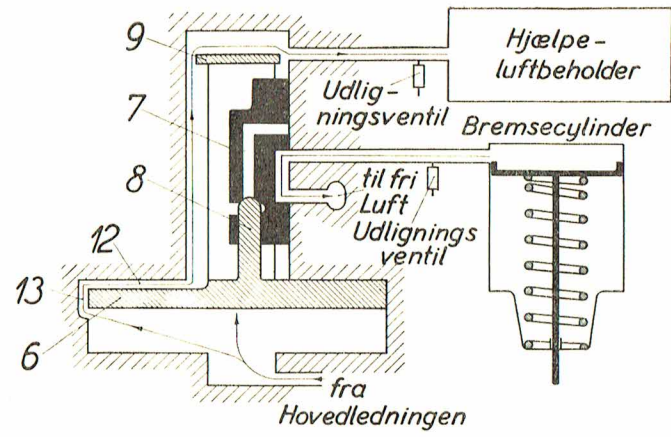

Fig. 339

Fig. 339

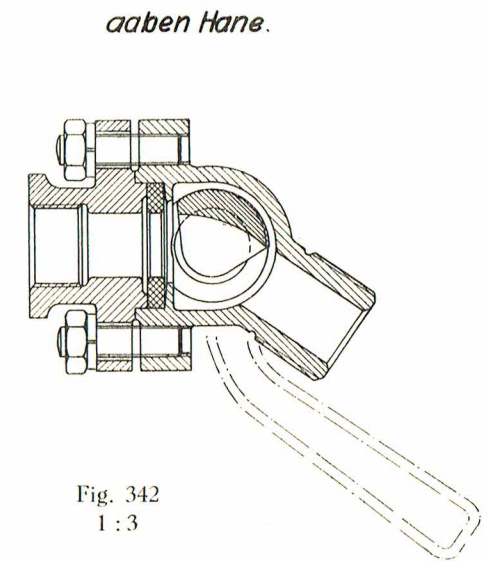
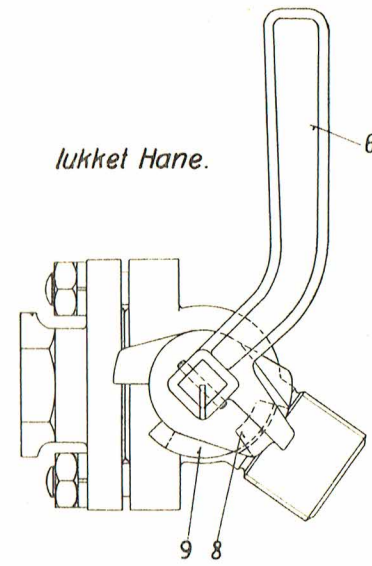

Fig. 342  
1:3

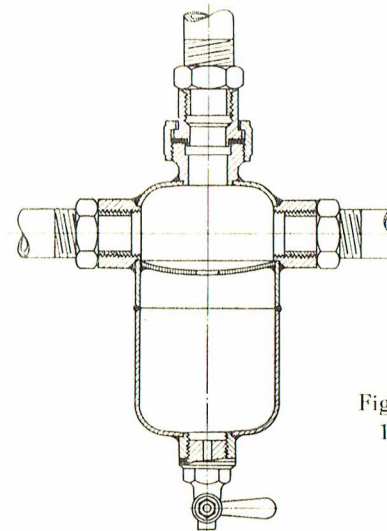
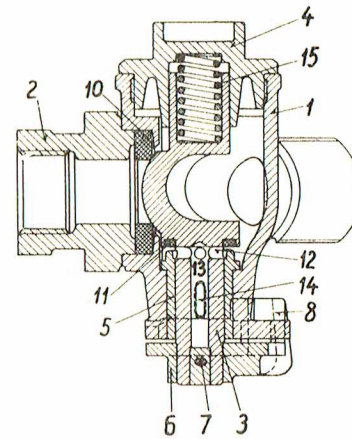

Fig. 341  
1:5

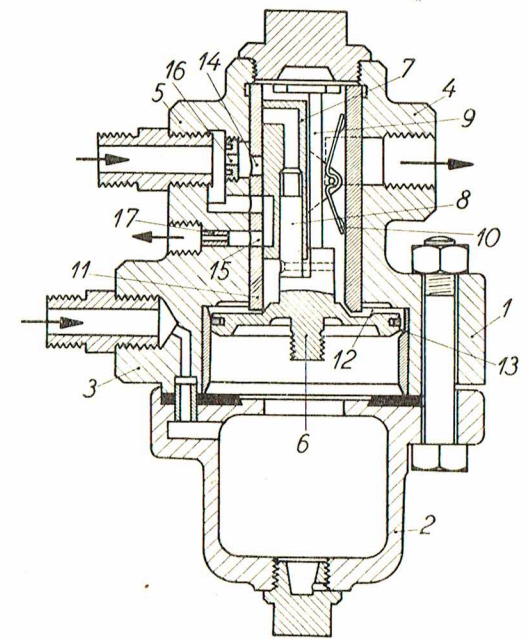

Fig. 340  
1:3

Fig. 340-342

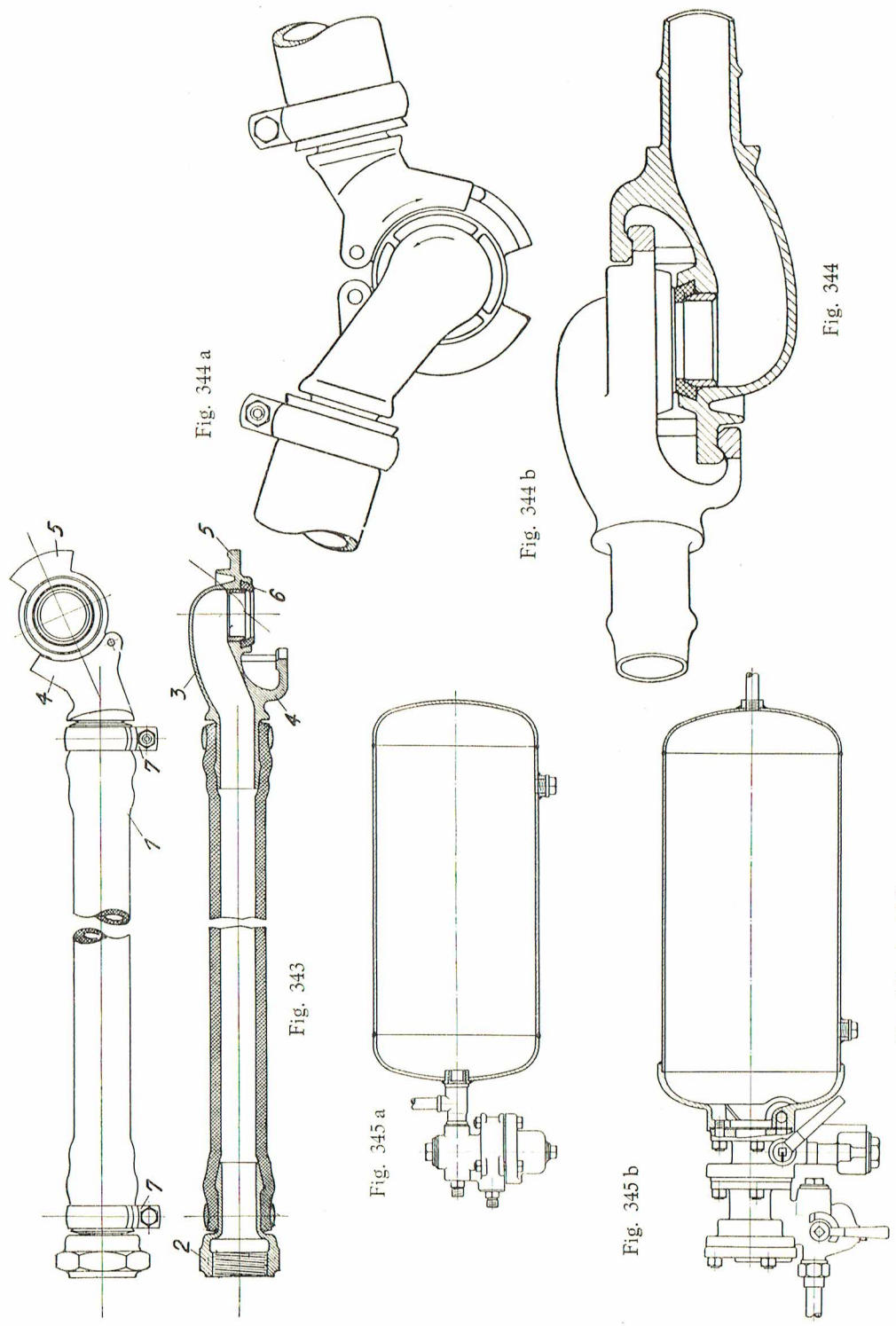

Fig. 343—345 b

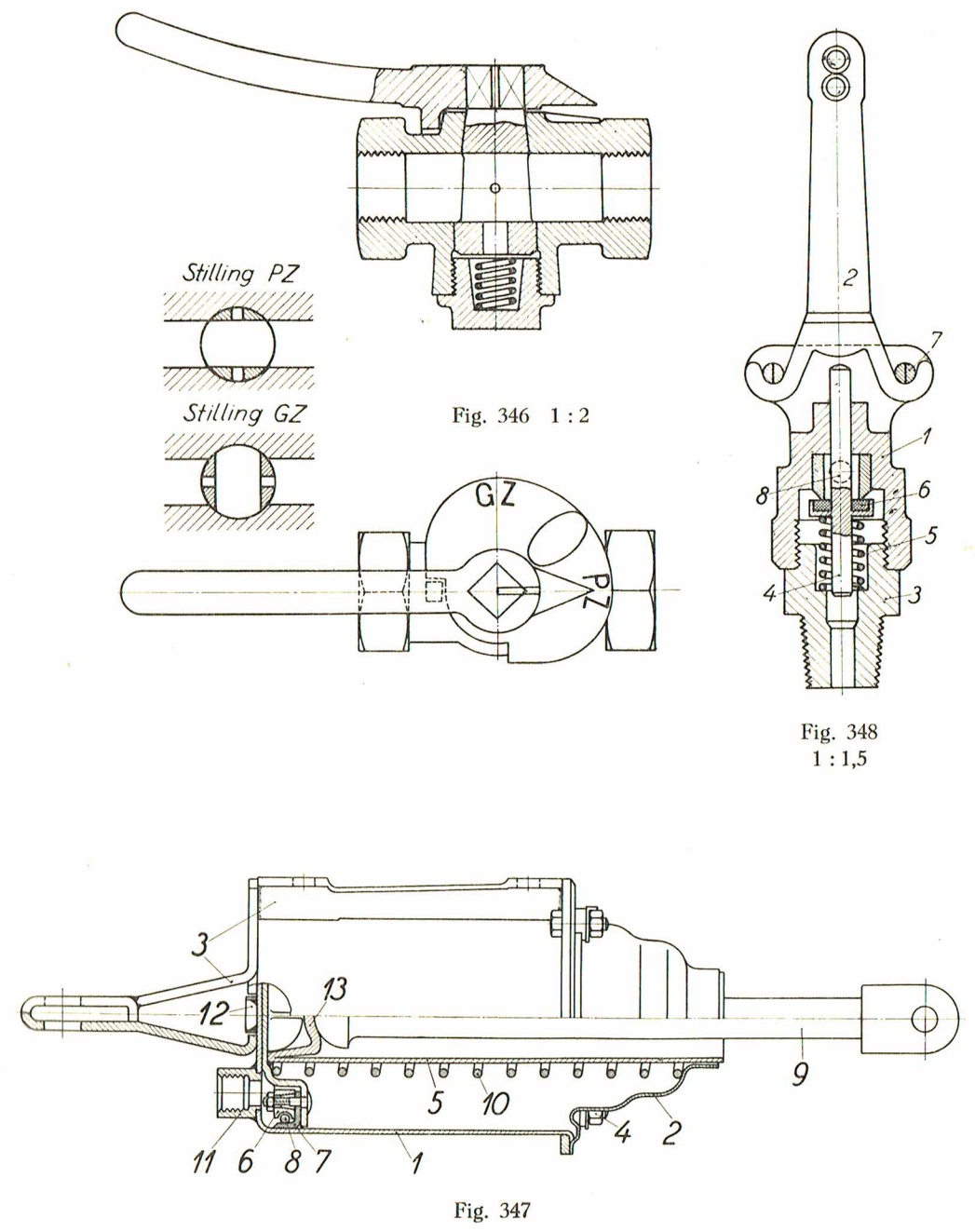

Fig. 346—348



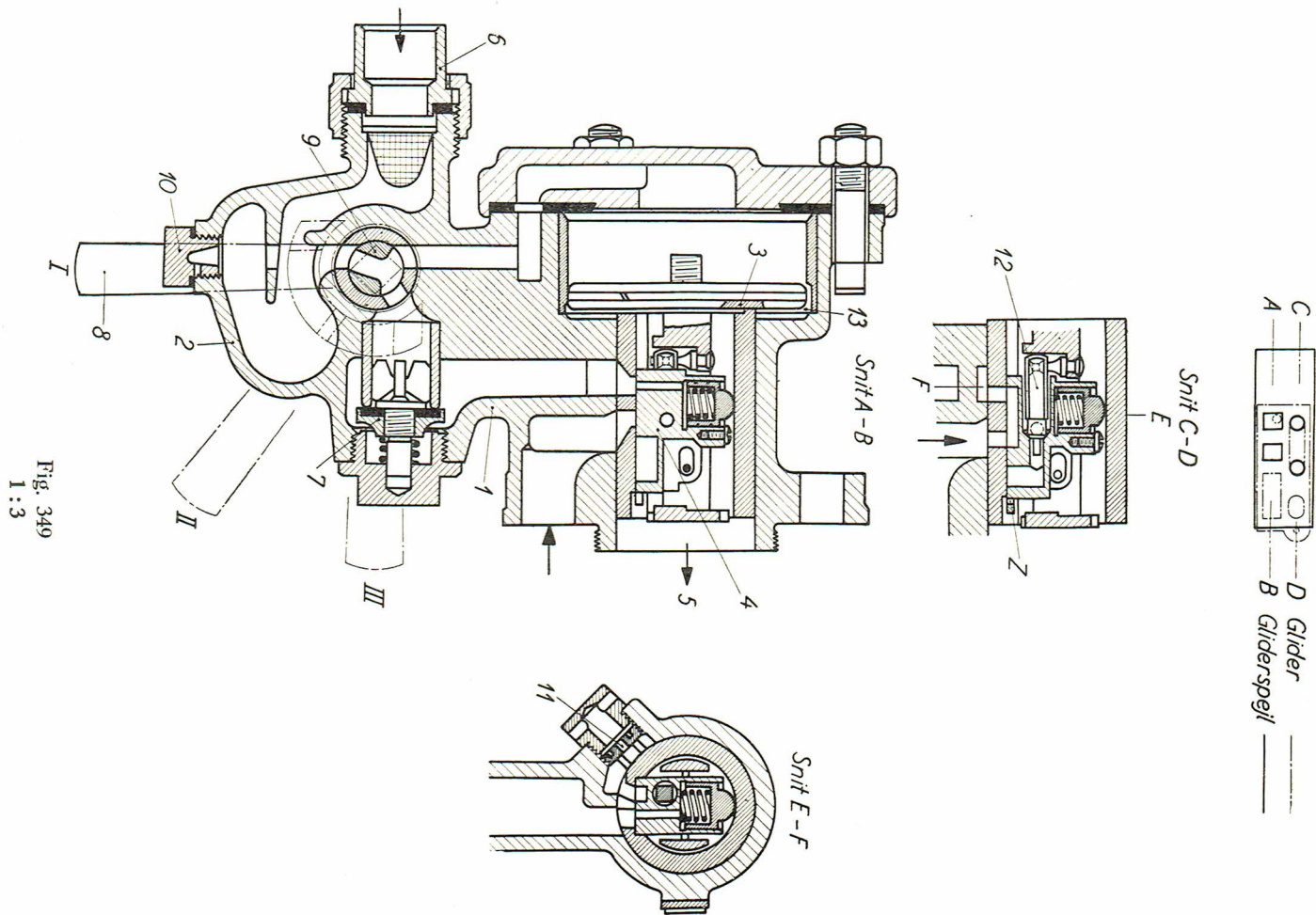

Fig. 349

Fig. 349  
1:3

11\*

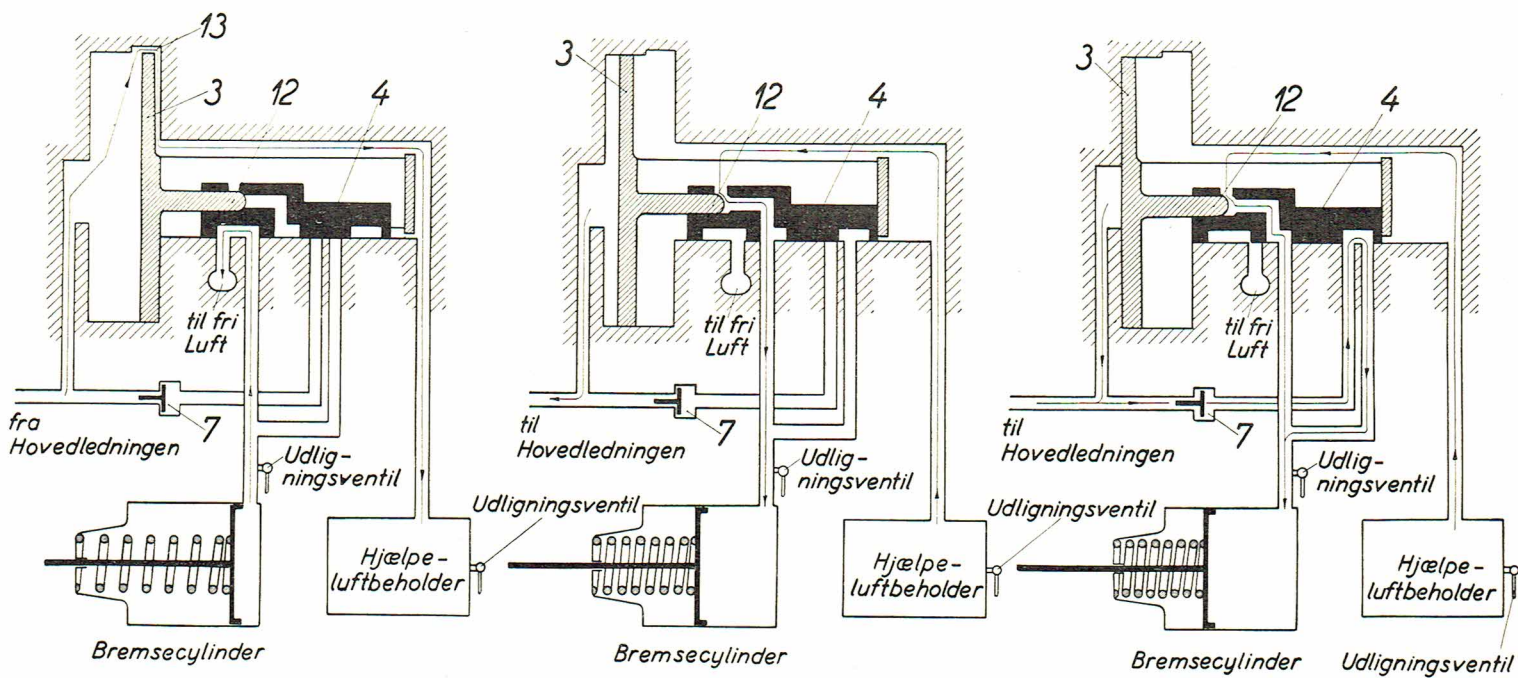

Fig. 350 a

Fig. 350 b

Fig. 350 c

Fig. 350

Fig. 350



Fig. 351—352

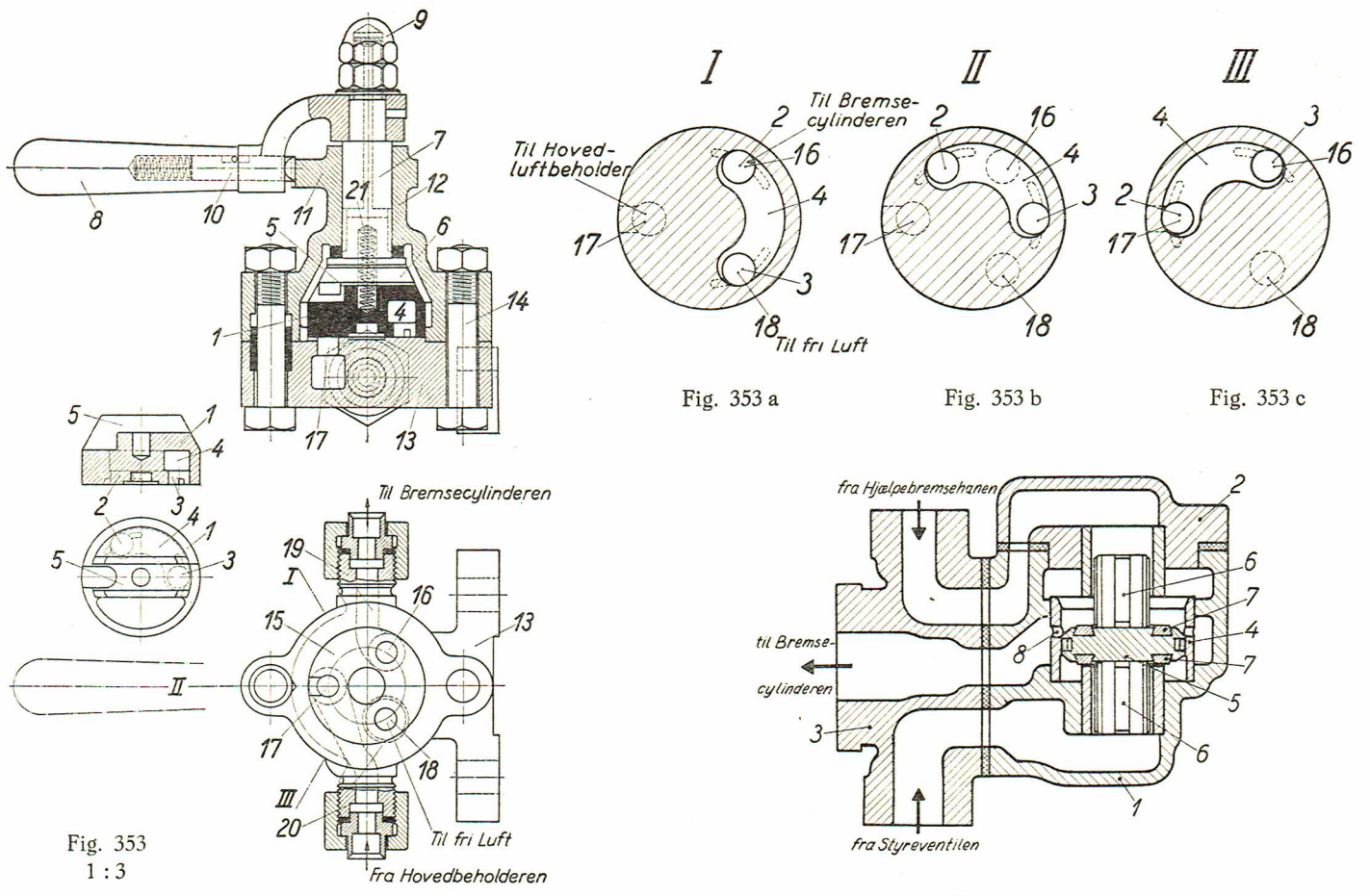
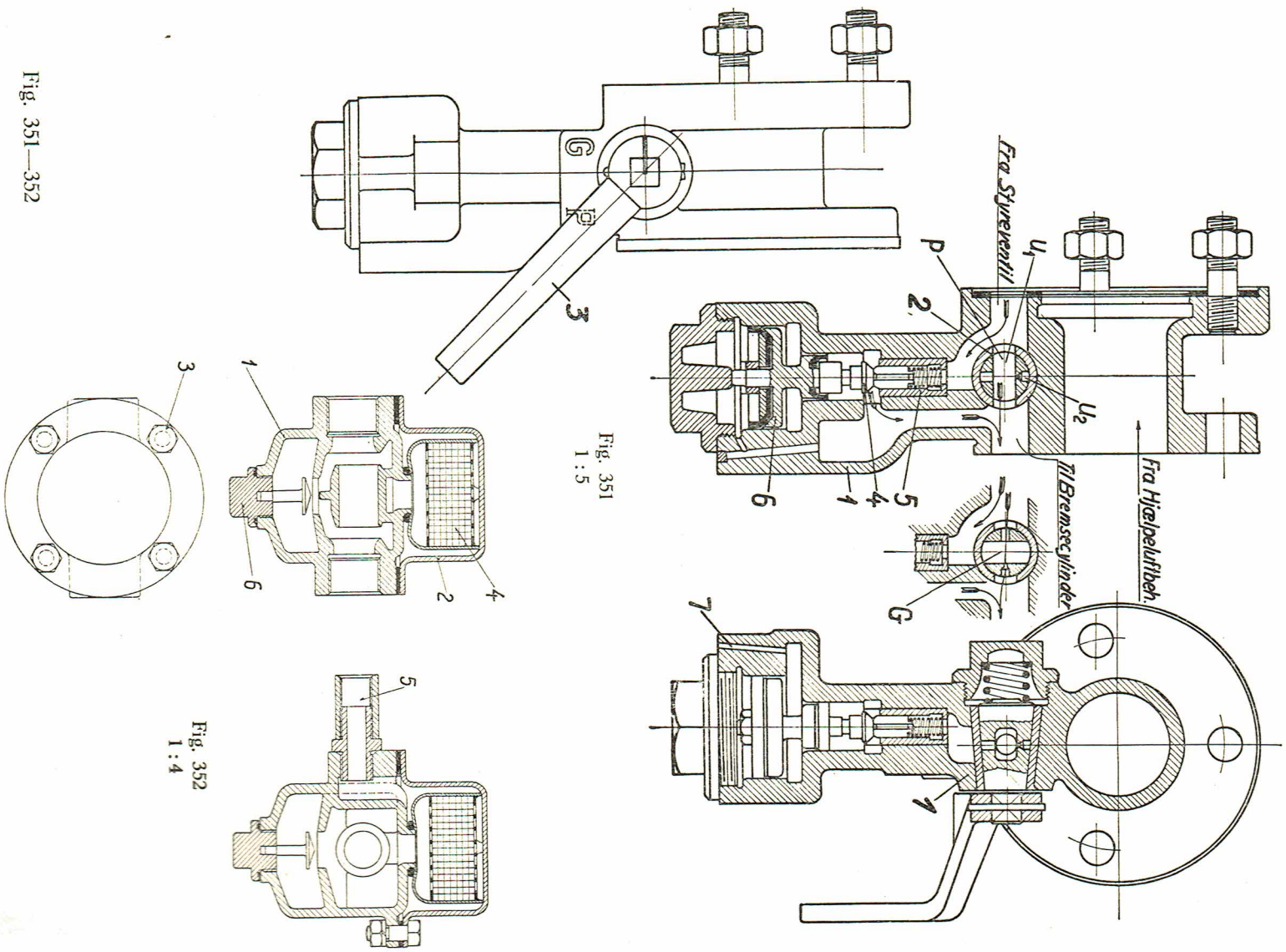

Fig. 353—354



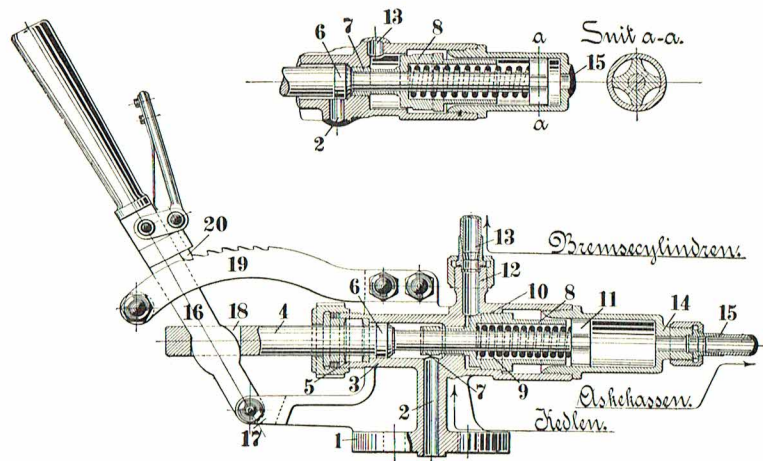

Fig. 355 1:6

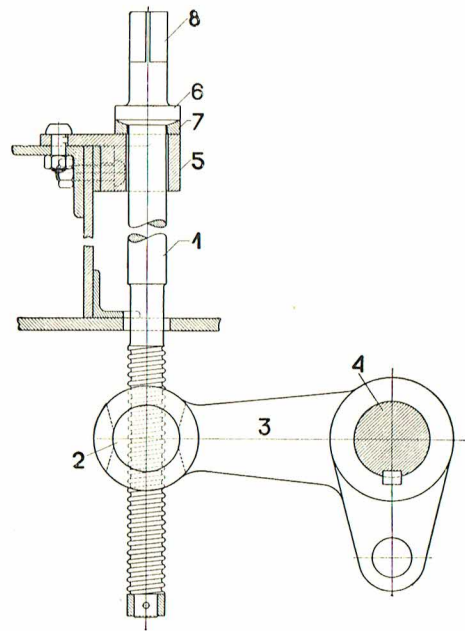

Fig. 357 1:8

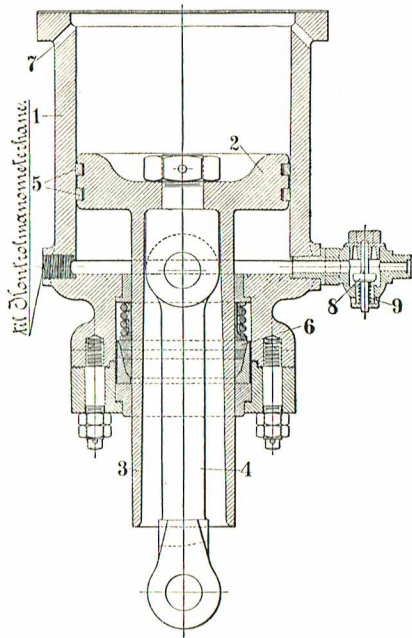

Fig. 356 1:8

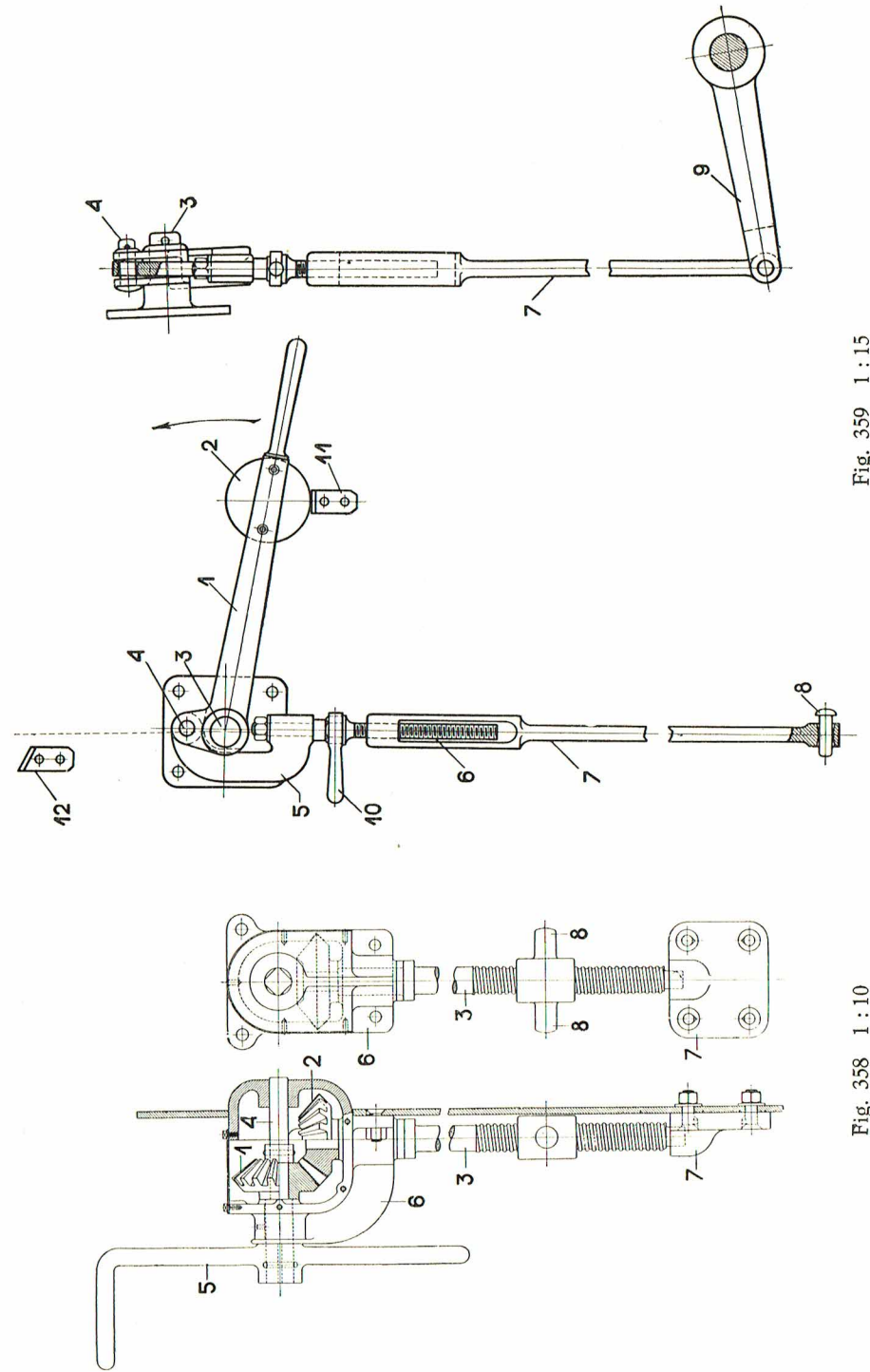

Fig. 359 1:15

Fig. 358 1:10



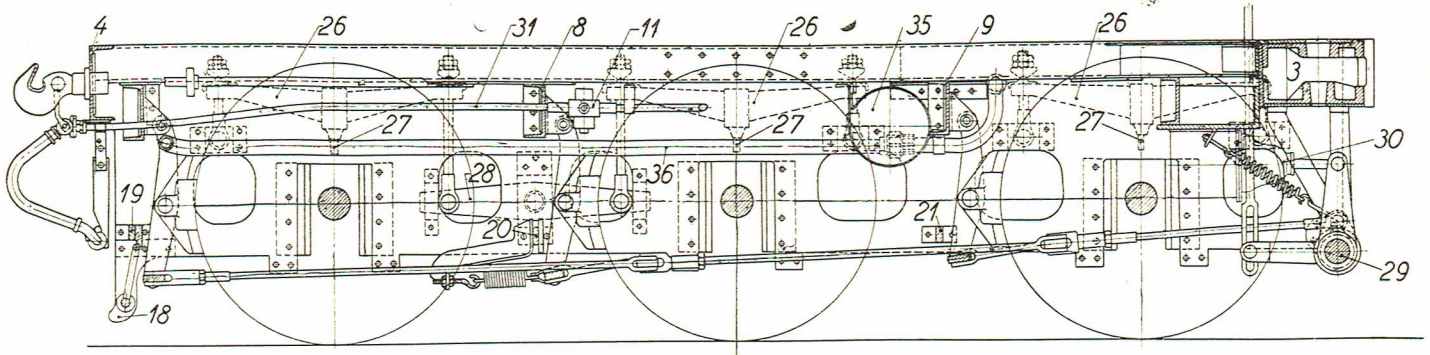

Fig. 360

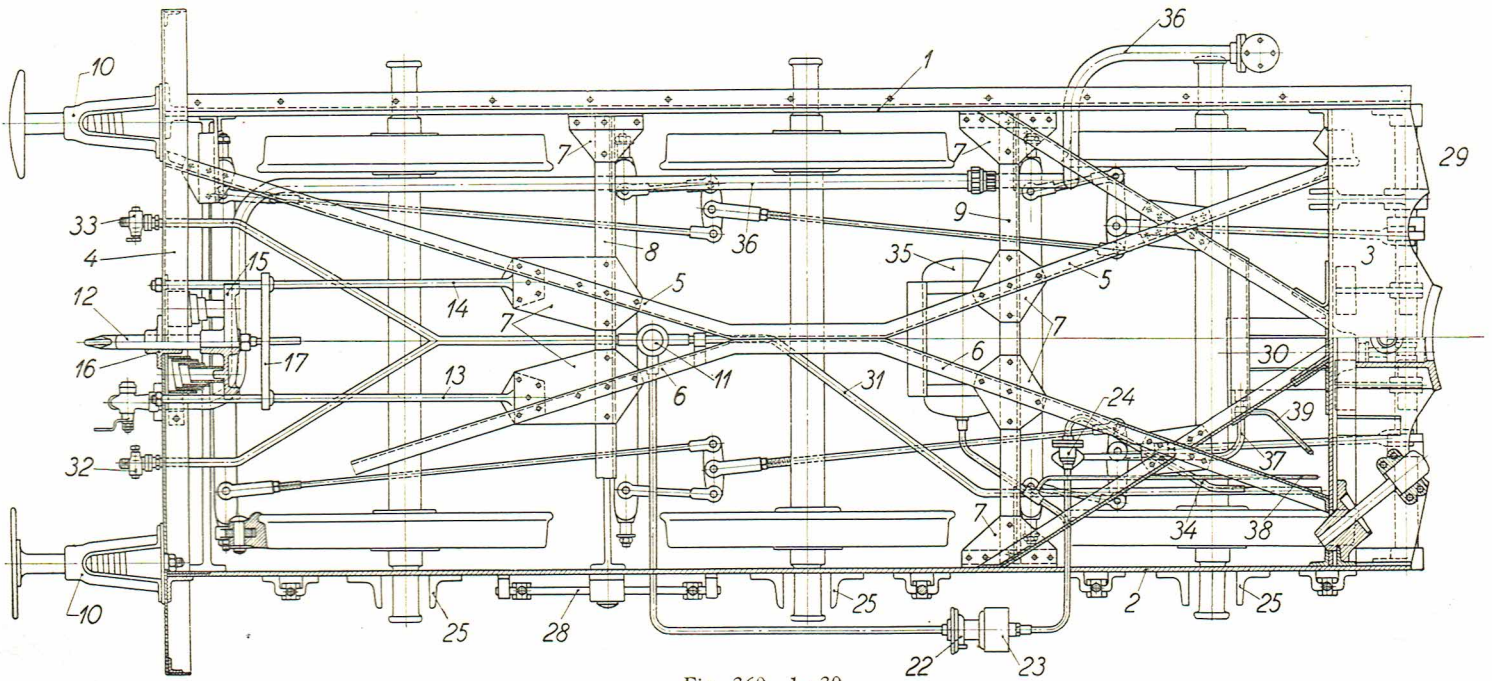
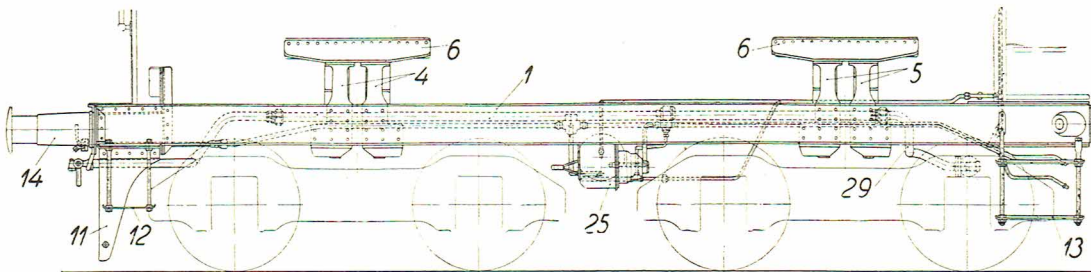

Fig. 360 1:30



Snit C-C

Snit D-D

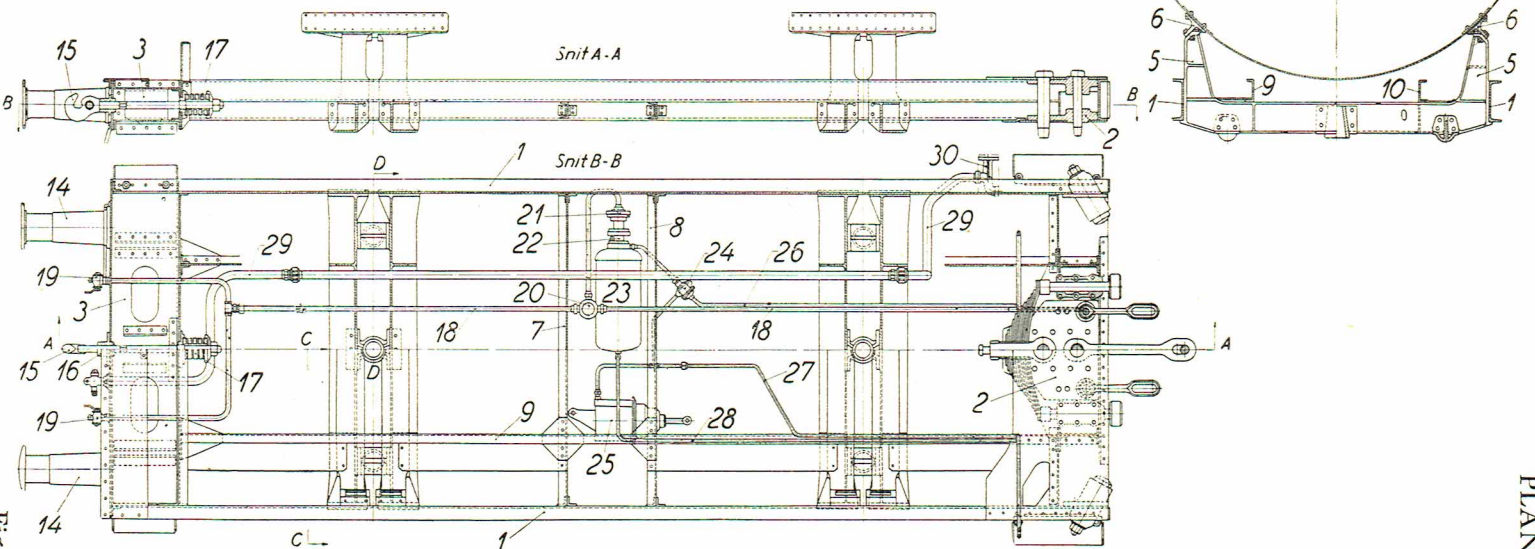

Fig. 361  
1:55

Fig. 361



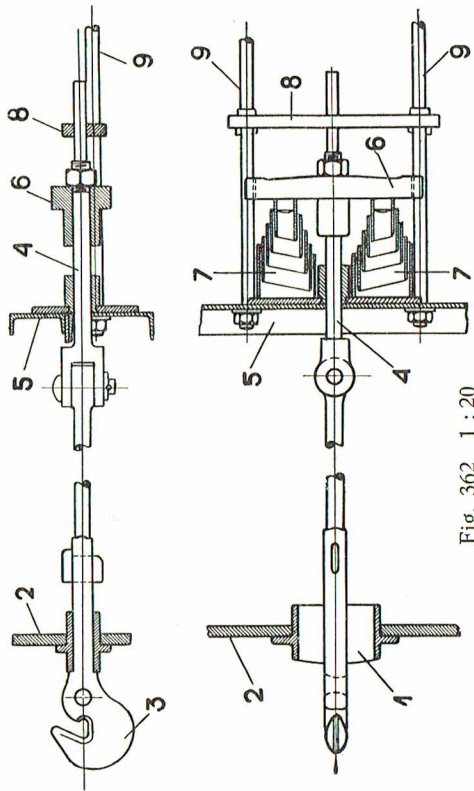

Fig. 362 1:20

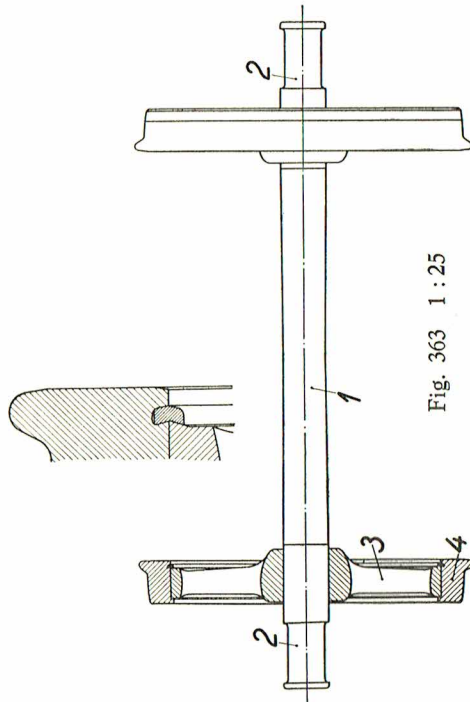
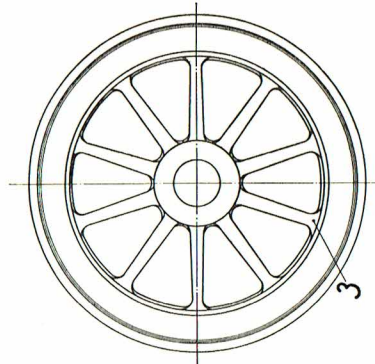

Fig. 363 1:25

Fig. 362—363

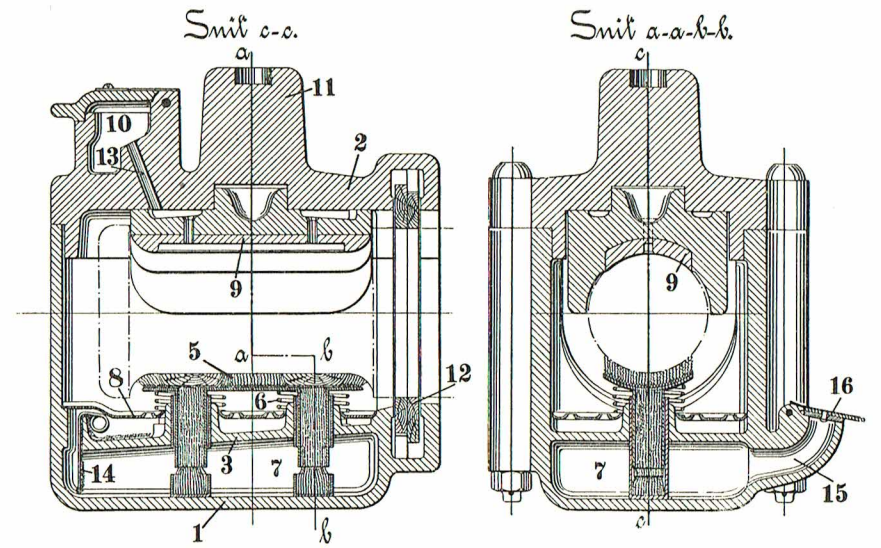

Fig. 364  
1:6

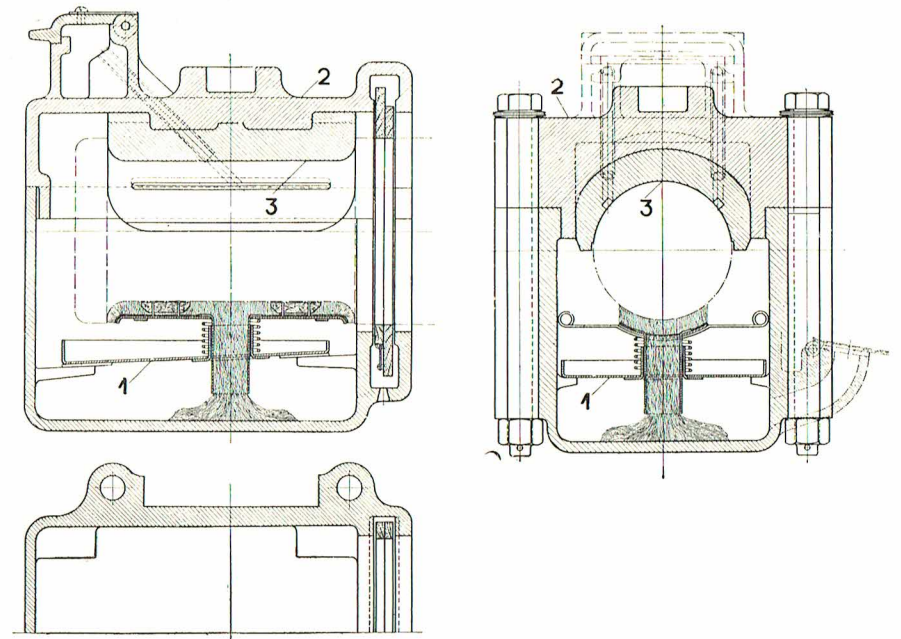

Fig. 365  
1:6

Fig. 364—365

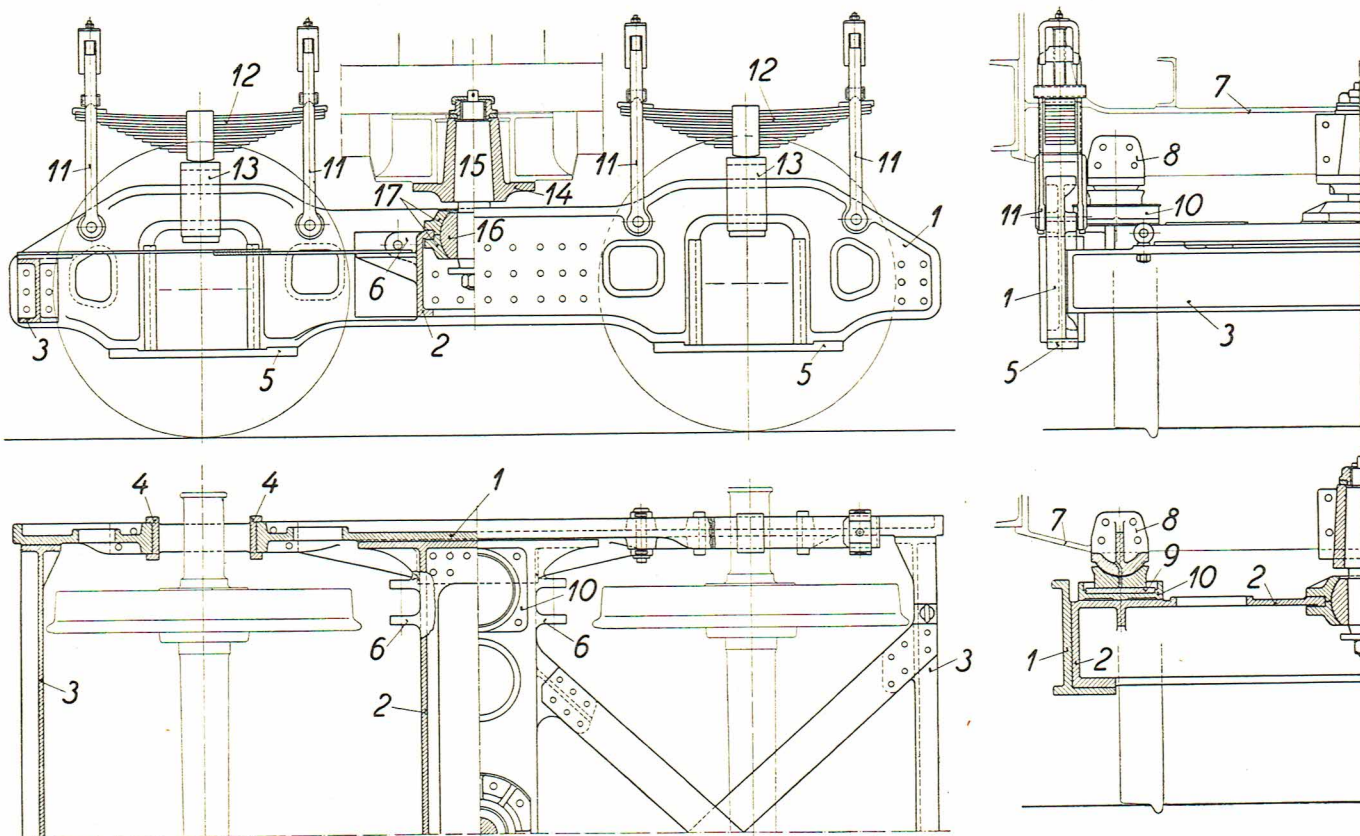

Fig. 366  
1 : 25



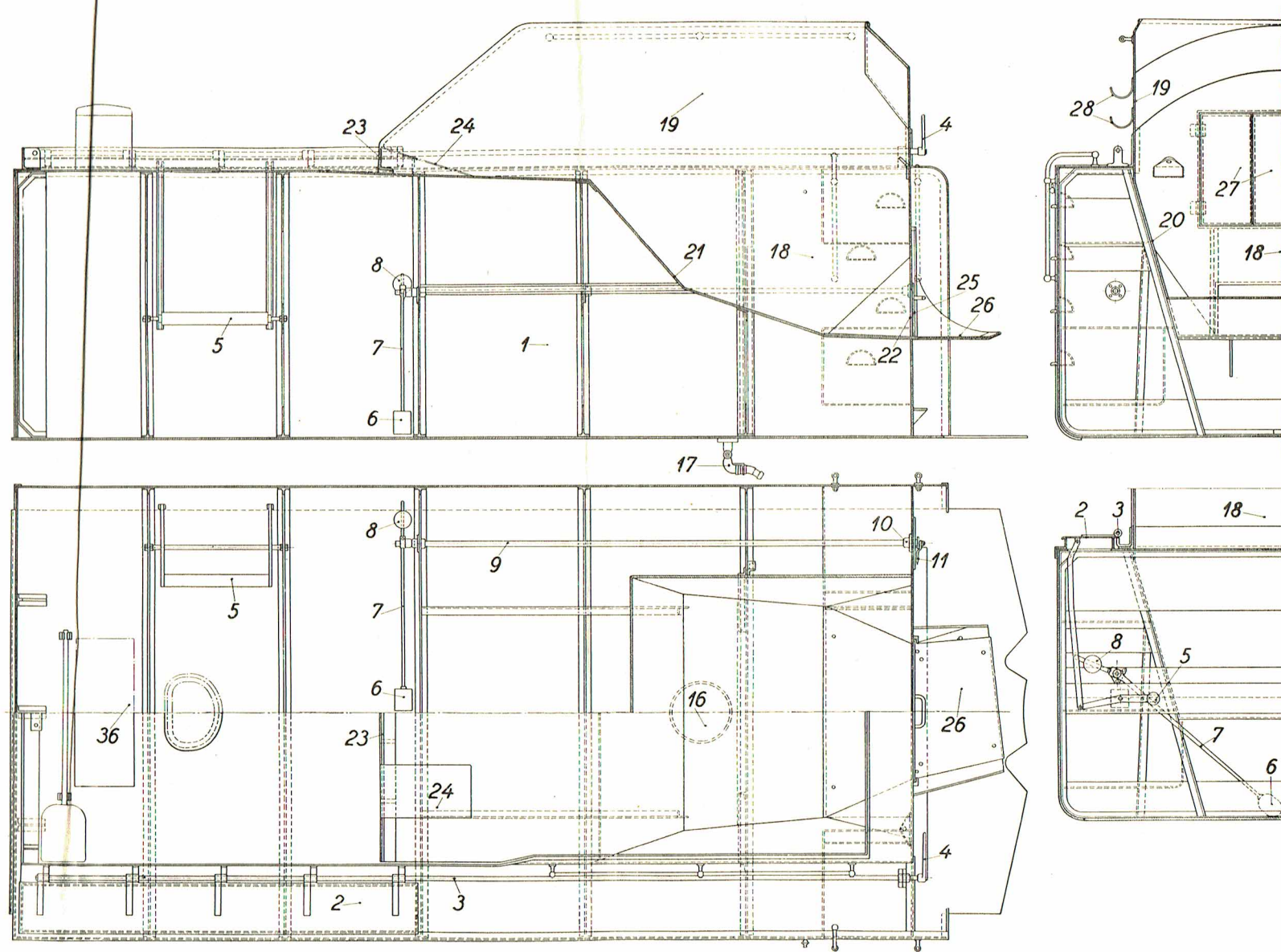

Fig. 367  
 1 : 40

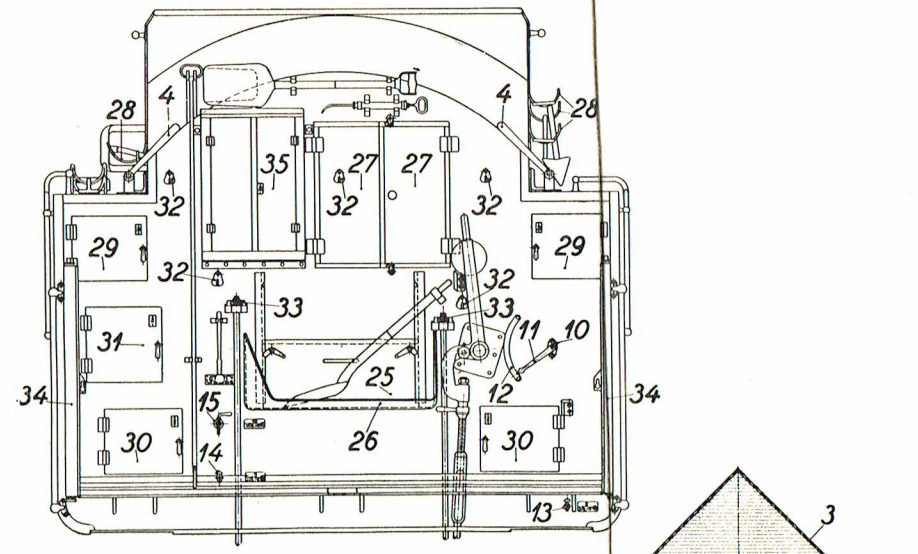

Fig. 367 a  
1:40

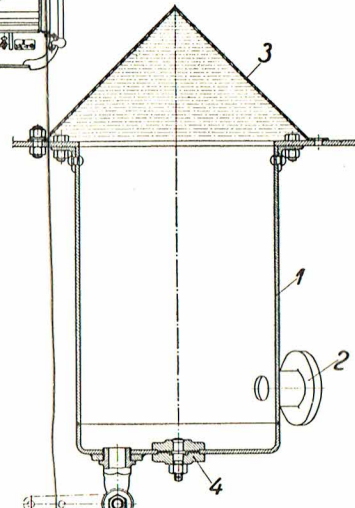

Fig. 368  
1:6

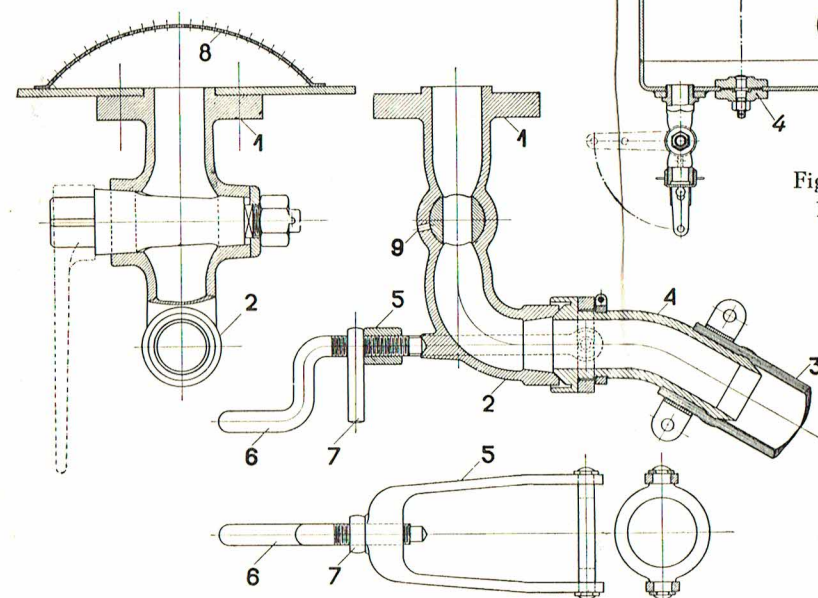

Fig. 369 1:6

Fig. 367 a—369

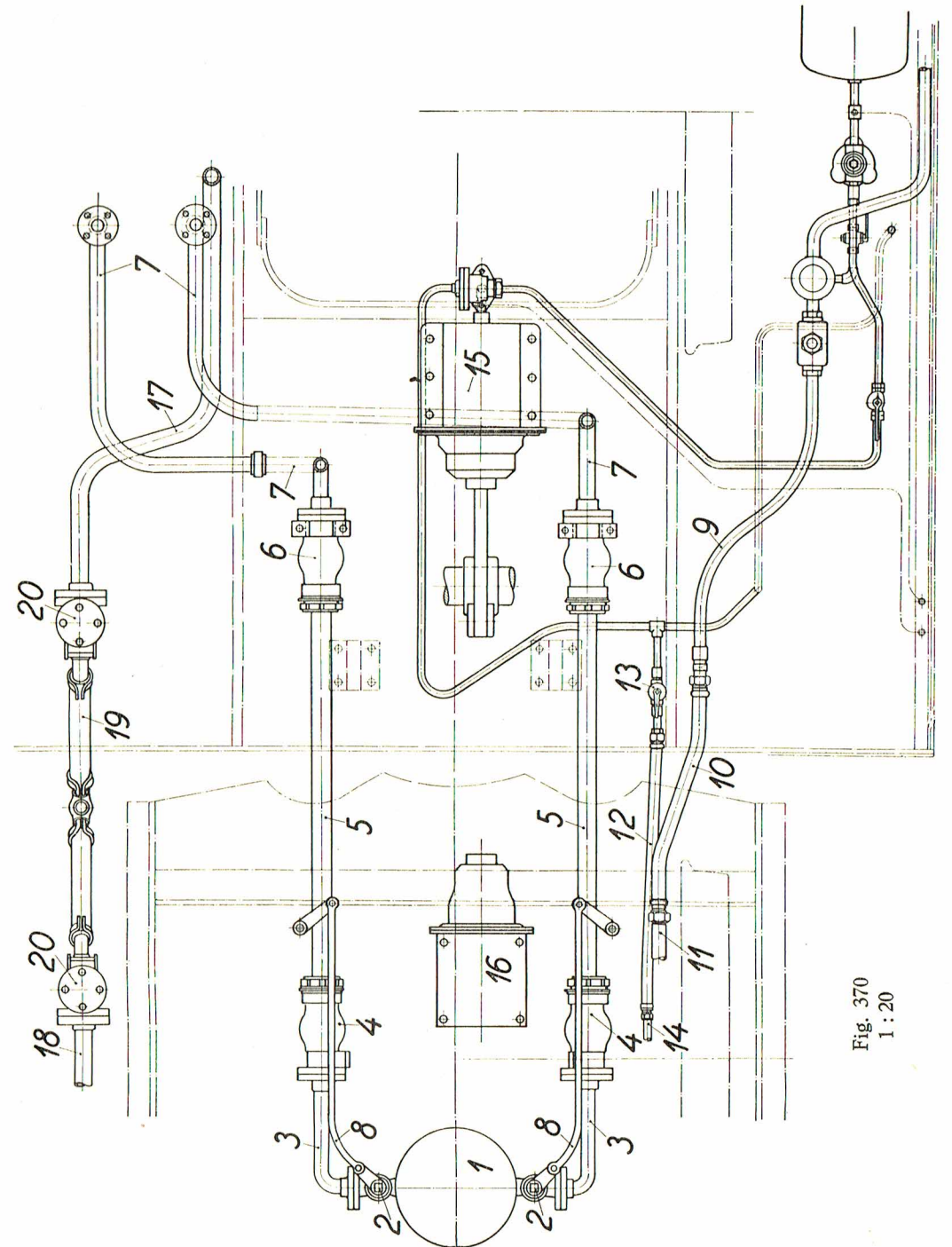

Fig. 370  
1:20

Fig. 370



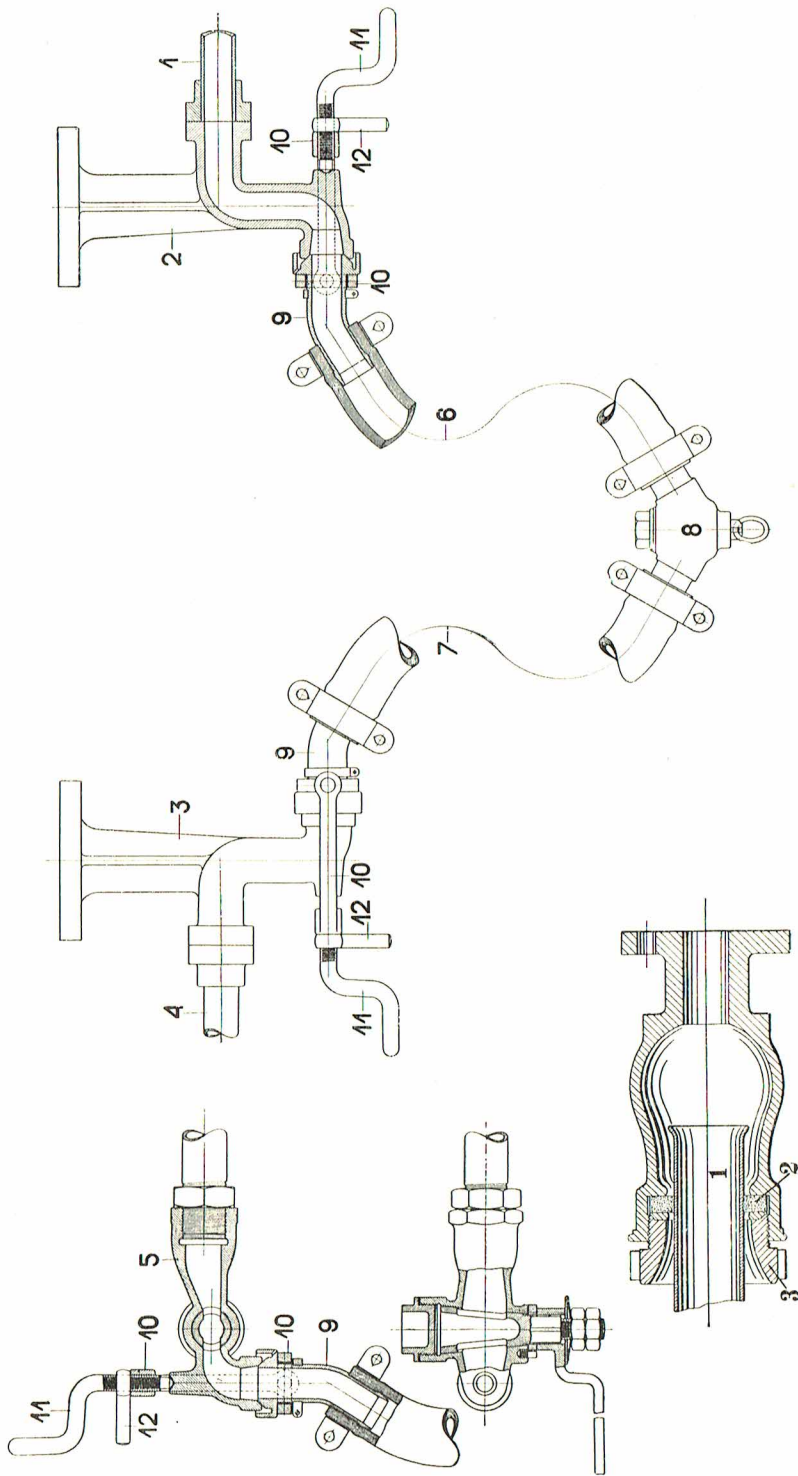

Fig. 372  
1:7

Fig. 371 1:6

Fig. 371—372

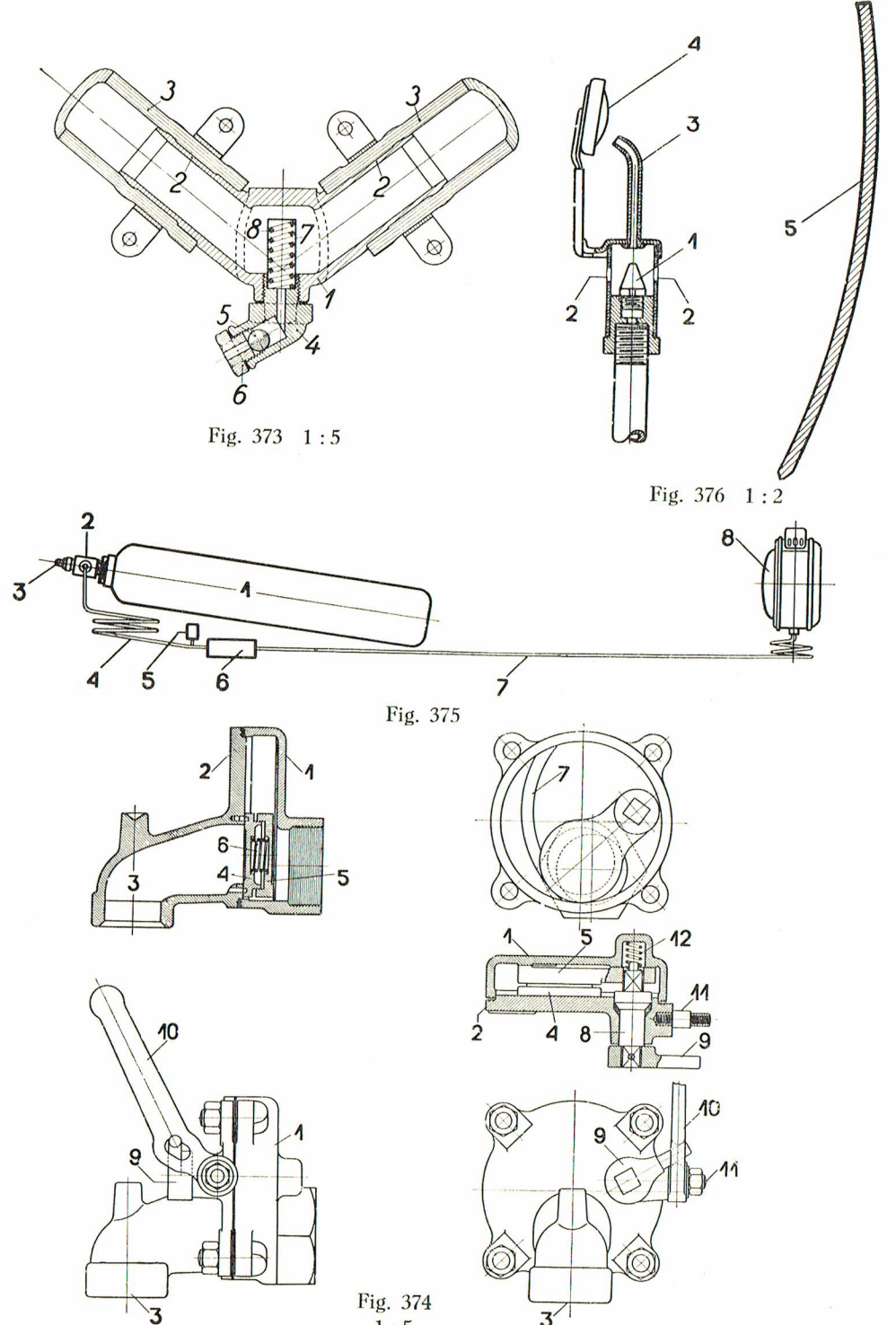

Fig. 373 1:5

Fig. 376 1:2

Fig. 375

Fig. 374  
1:5

Fig. 373—376

Fig. 377—380

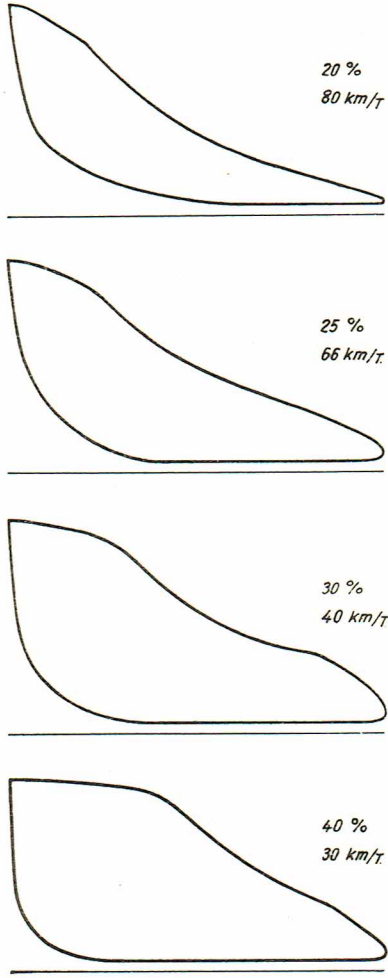

Fig. 377

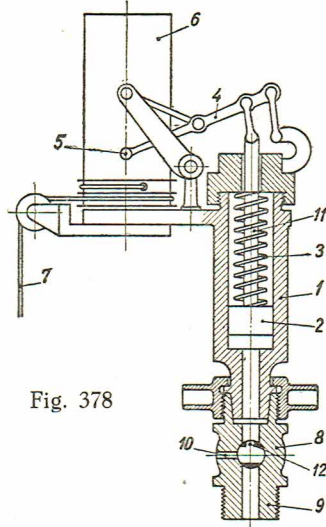

Fig. 378

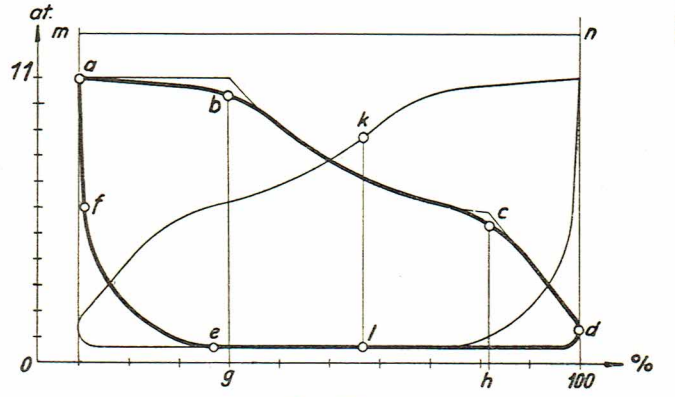

Fig. 379

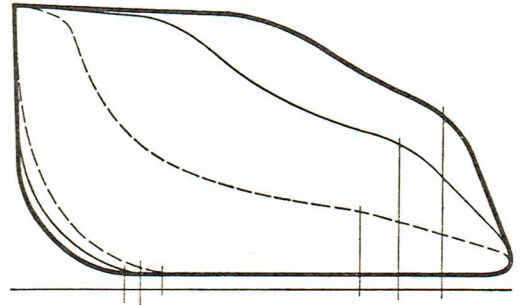

Fig. 380

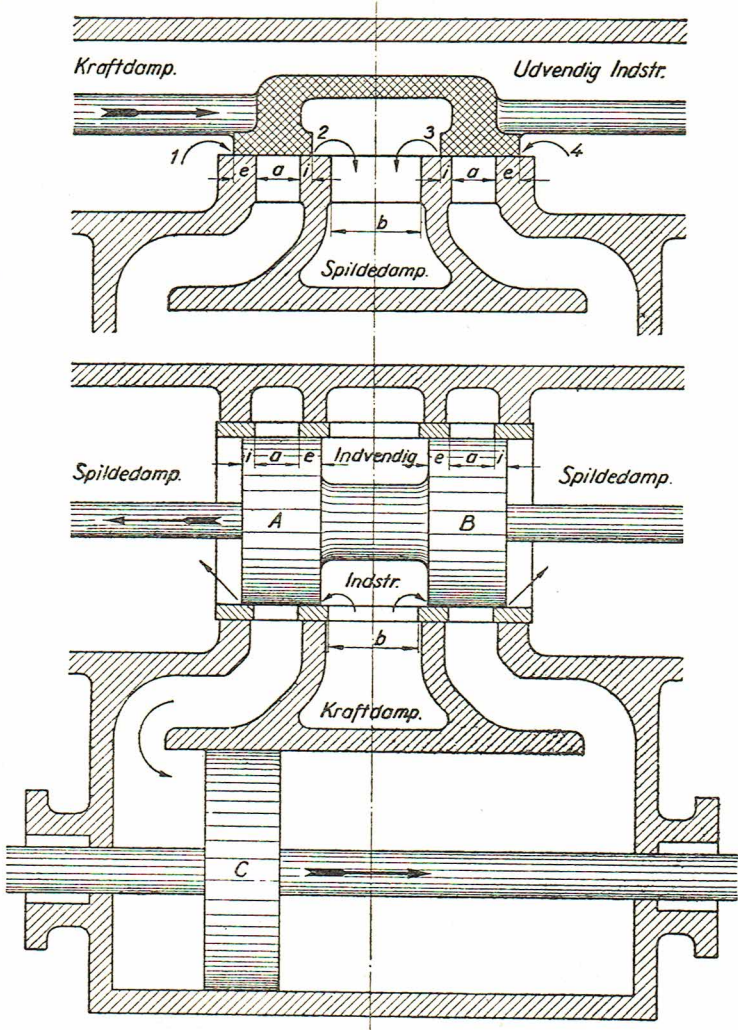

Fig. 381

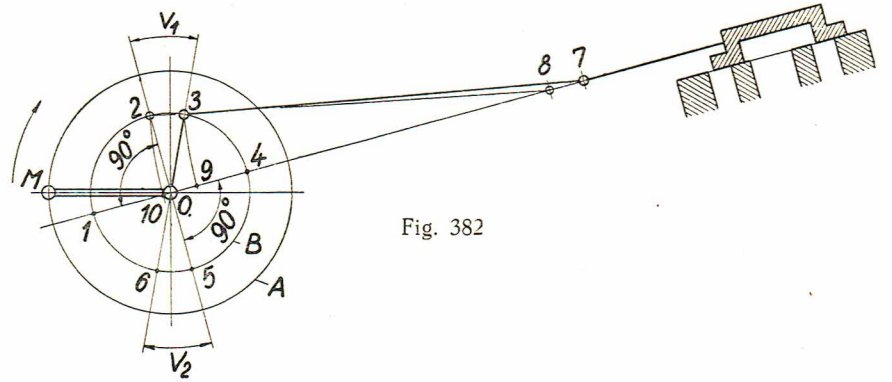

Fig. 382

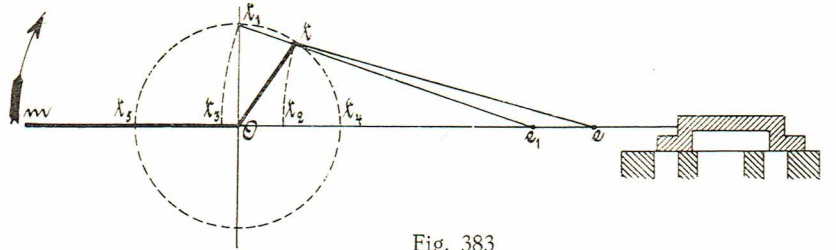

Fig. 383

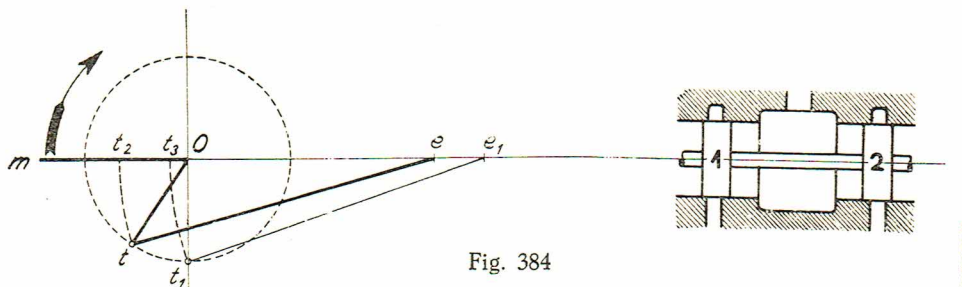

Fig. 384



PLAN 169

Fig. 385

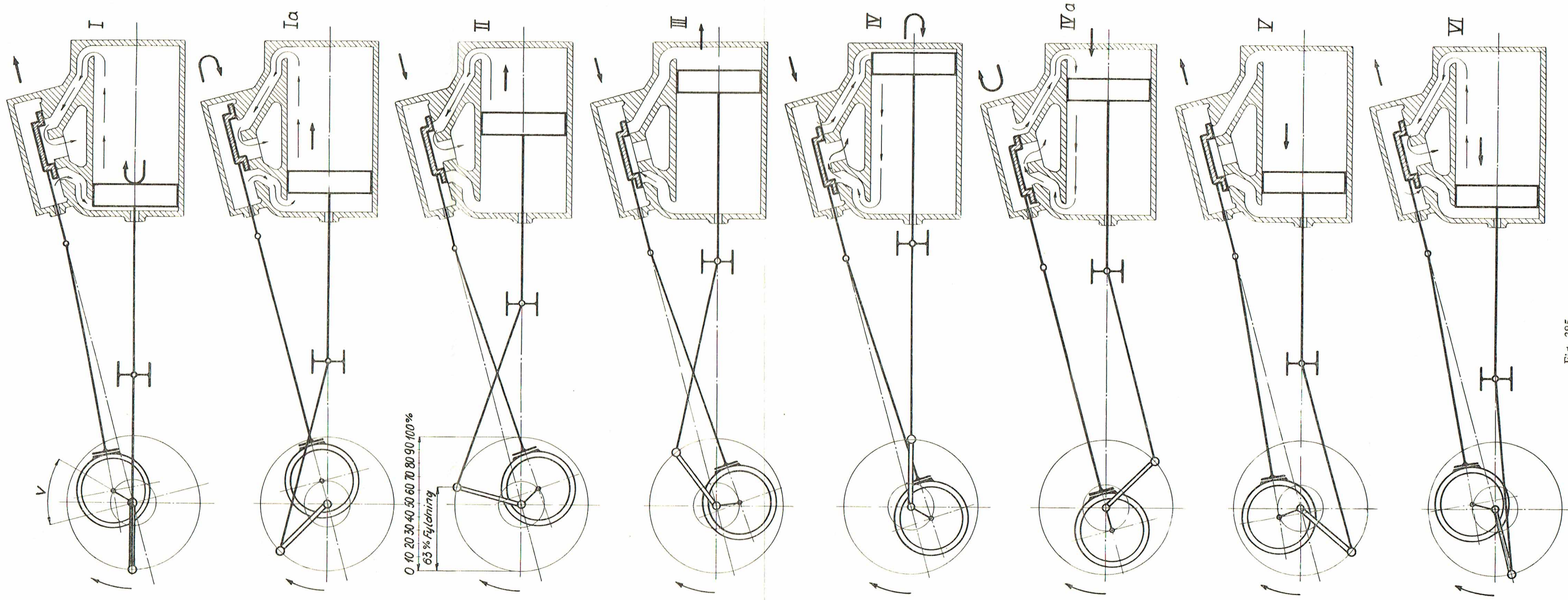

Fig. 385



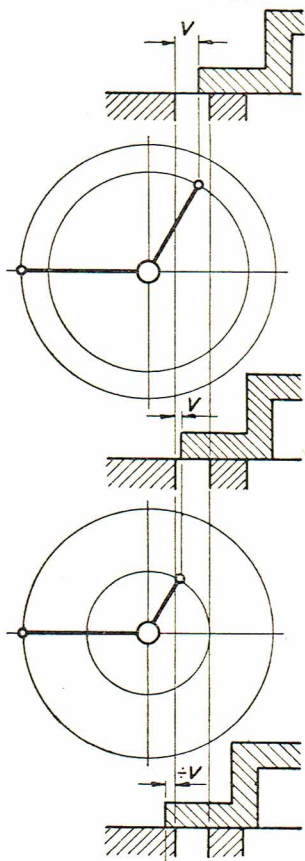

Fig. 386—388 c

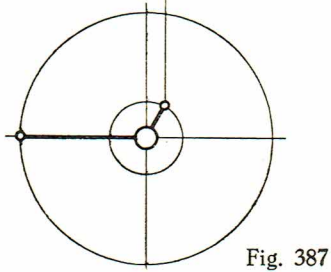

Fig. 387

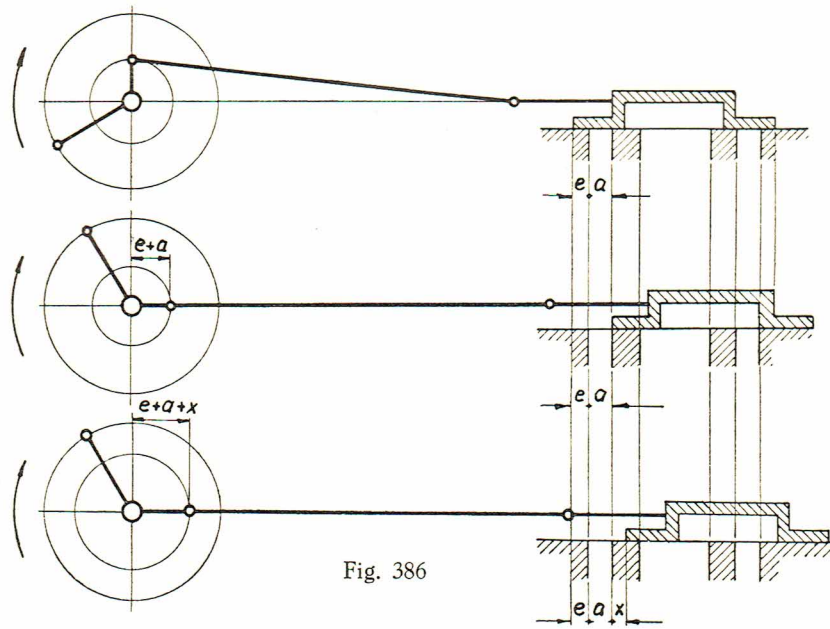

Fig. 386

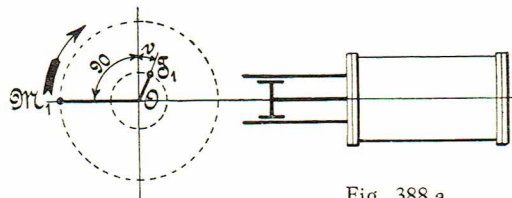

Fig. 388 a

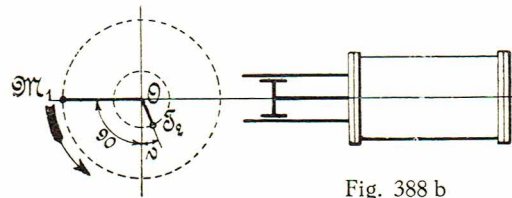

Fig. 388 b

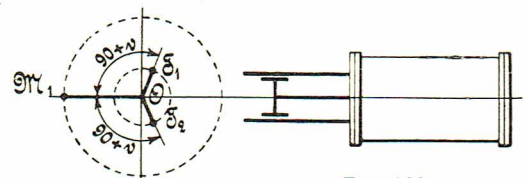

Fig. 388 c

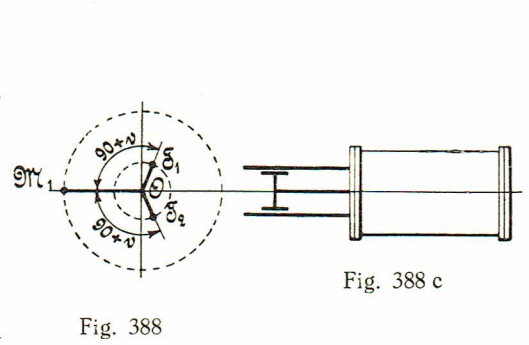

Fig. 388

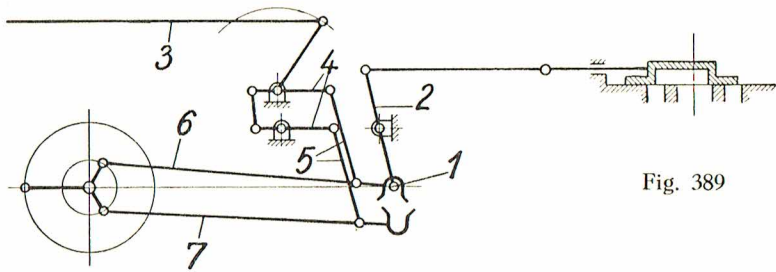

Fig. 389

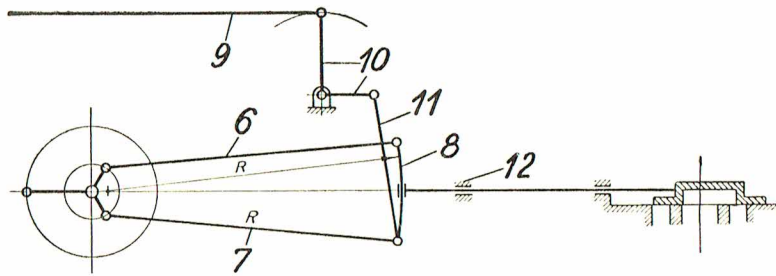

Fig. 390

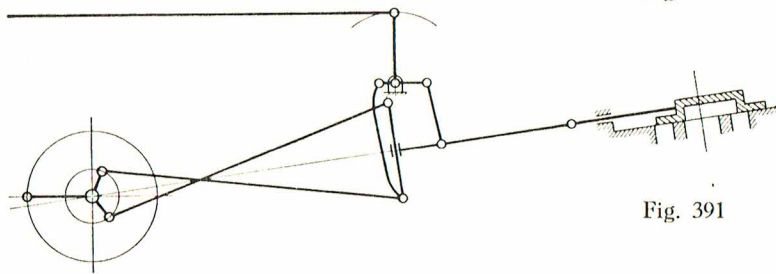

Fig. 391

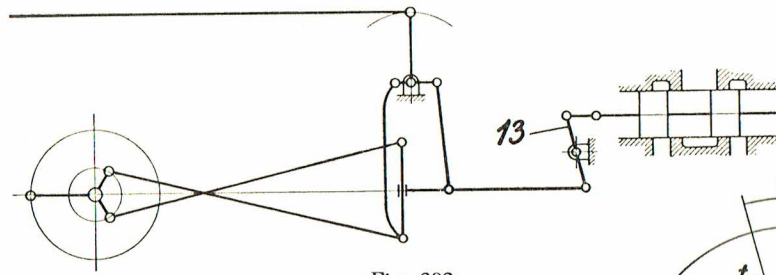

Fig. 392

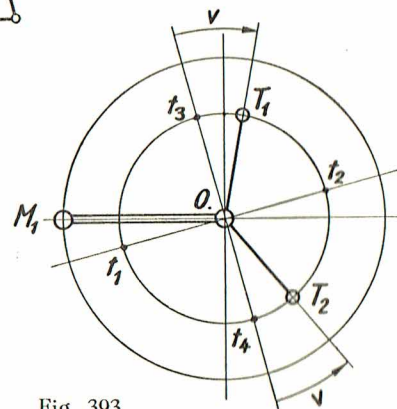

Fig. 393

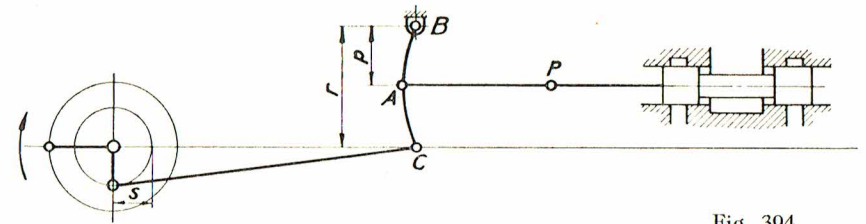

Fig. 394

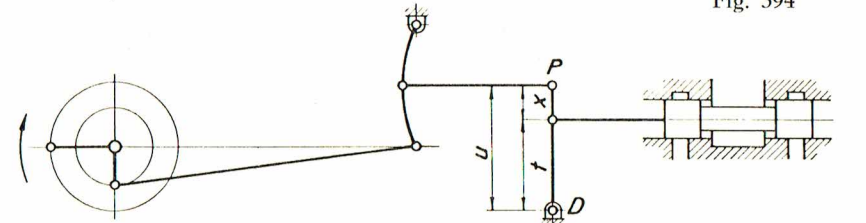

Fig. 395

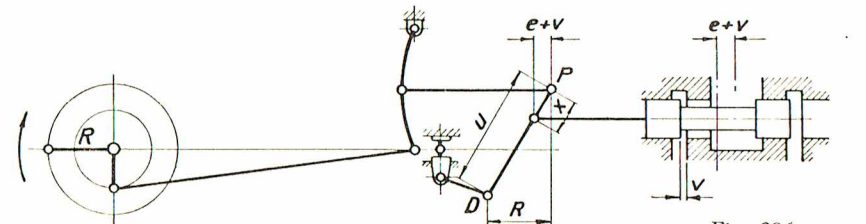

Fig. 396

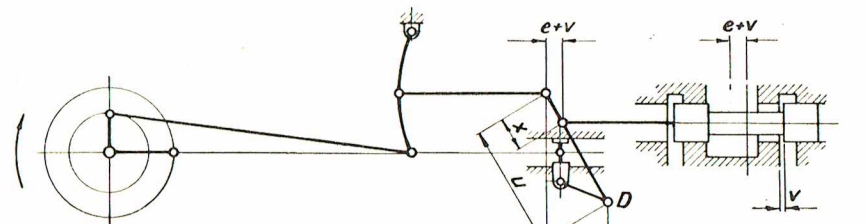

Fig. 397

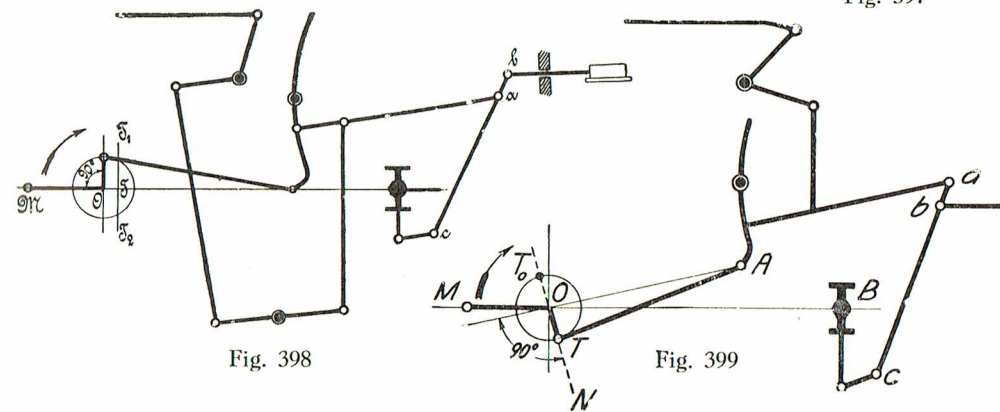

Fig. 398

Fig. 399



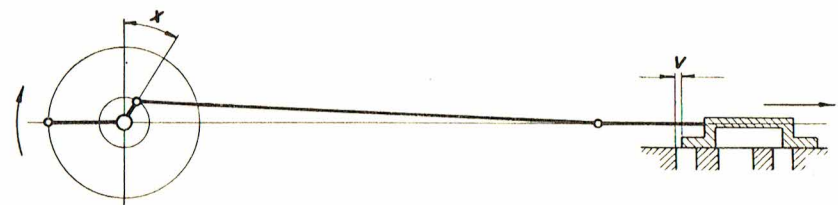

Fig. 400



Fig. 401

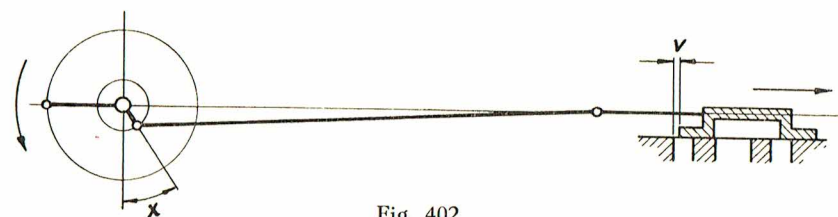

Fig. 402

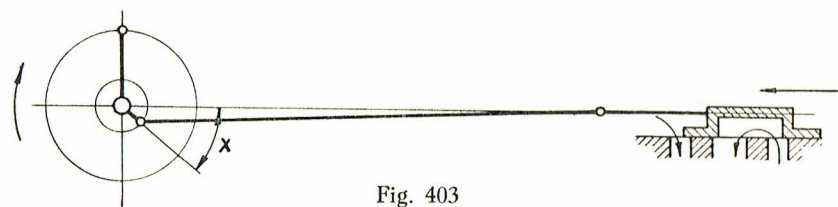

Fig. 403



Fig. 404



Fig. 405

Fig. 400—405

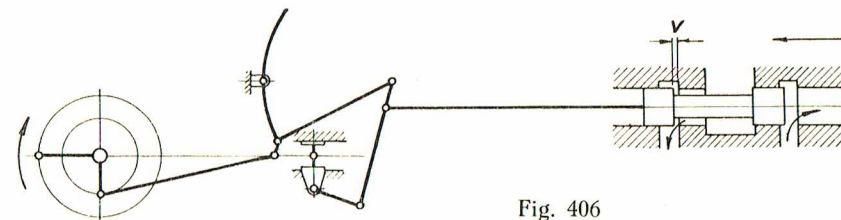

Fig. 406

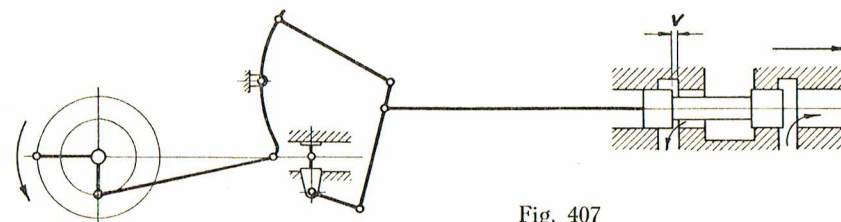

Fig. 407

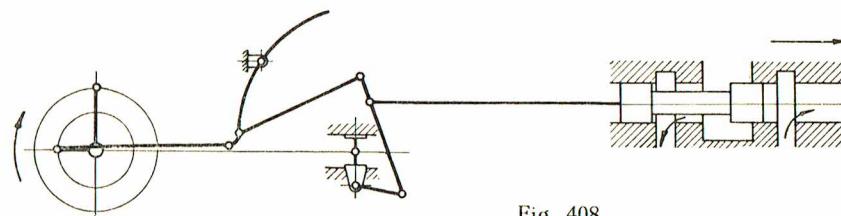

Fig. 408

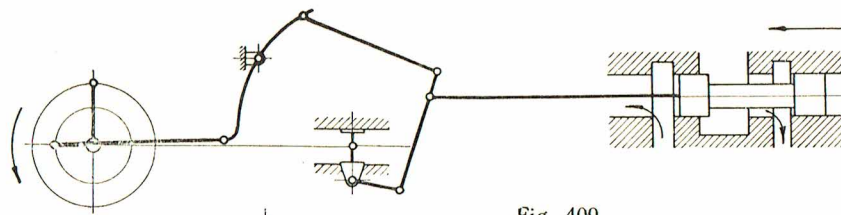

Fig. 409

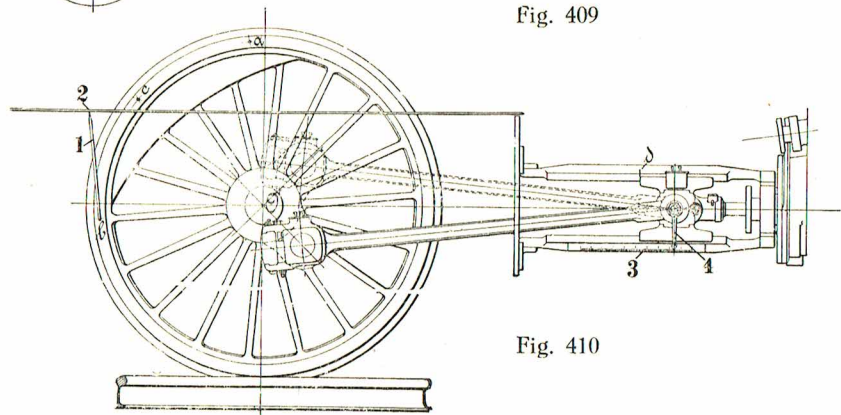

Fig. 410

Fig. 406—410

Fig. 411-413

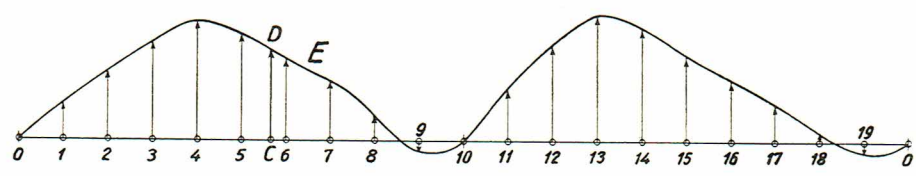

Fig. 413

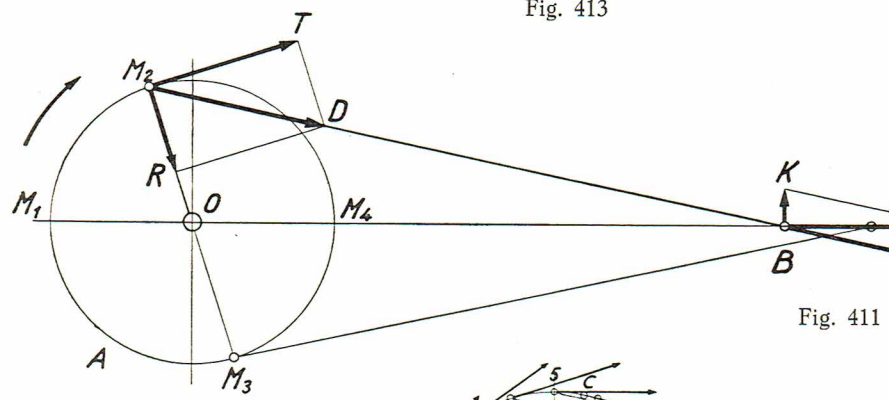

Fig. 411

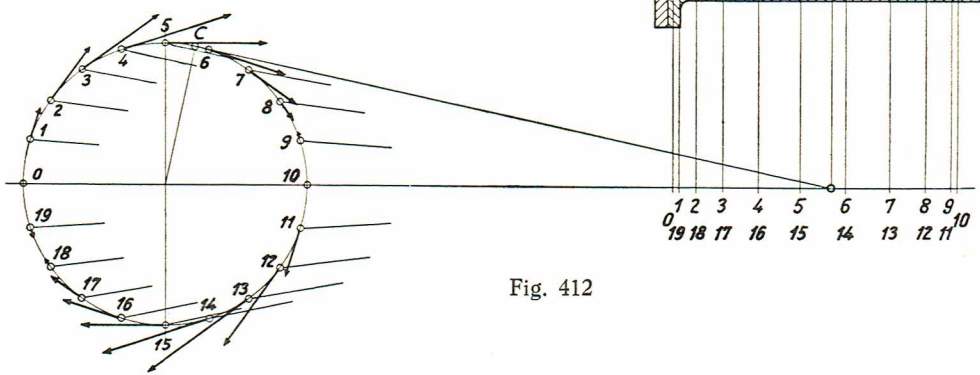

Fig. 412

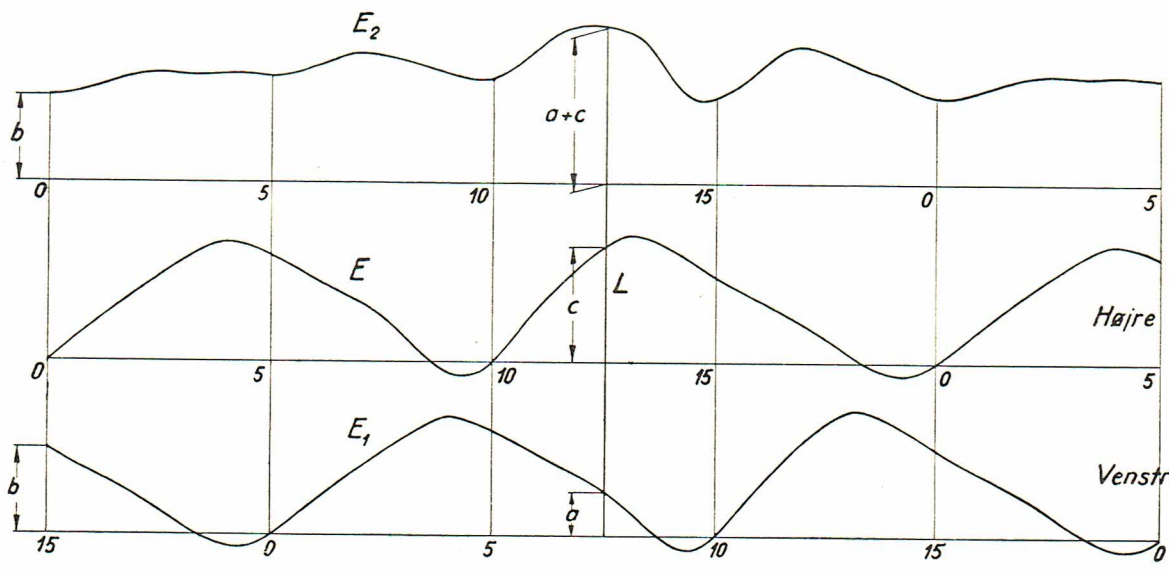
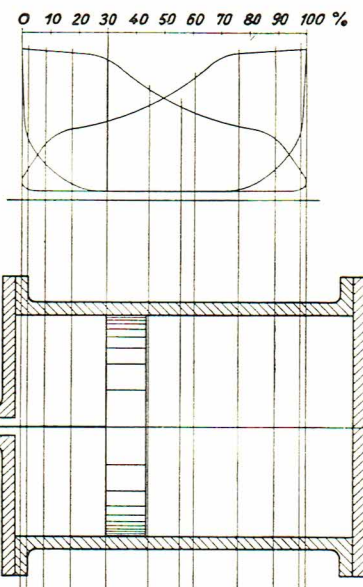

Fig. 414



Fig. 417

Fig. 414-417

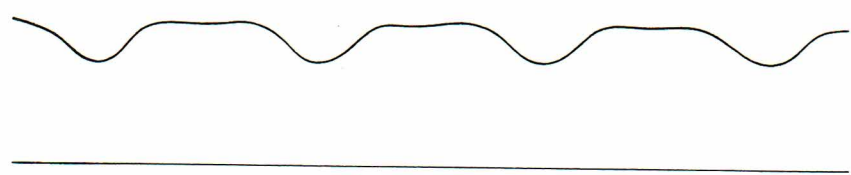

Fig. 415

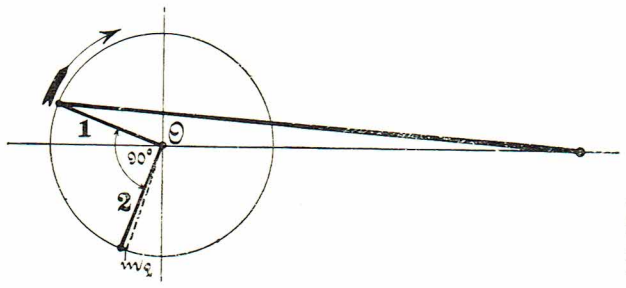

Fig. 416



